

PRO WELD

INTERNATIONAL

CD-212 GAP



OPERATION/MAINTENANCE MANUAL

TABLE OF CONTENTS

1.0	INTRODUCTION	1
2.0	WARRANTY	1
3.0	UNPACKING YOUR UNIT	1
4.0	SUGGESTED SAFETY PRECAUTIONS	1
5.0	GENERAL DESCRIPTION	2
6.0	THE CD WELDING PROCESS	2
7.0	POWER REQUIREMENTS	3
8.0	SYSTEM SPECIFICATIONS	3
9.0	WELDING SYSTEM HOOK-UP	4
9.1	Straight Polarity	4
9.2	Reverse Polarity	5
10.0	SYSTEM OPERATION	6
11.0	GUN SET-UP	7
11.1	Standard	7
11.2	Installing or Changing Collets or Chucks	8
11.3	For Weld Pins with Collet Protector	8
11.4	Template Adapter	9
11.5	Collet Protector with Blunt Leg	9
11.6	Parts List Gap Gun	10
11.7	Adjusting Gap Gun	11
11.8	Installation of Collet	12
11.9	Adjusting Spring Pressure	13
11.6	Parts List LD CD Handgun	15
12.0	WELDABLE MATERIAL COMBINATIONS	16
13.0	CAUSES OF POOR OR ERRATIC WELDS	13
14.0	TROUBLE SHOOTING POOR WELDS	17
15.0	ROUTINE WELDER MAINTENANCE	18
16.0	ASSEMBLY –CD-212 CONTROLLER	19.20
16.1	PC Board Assembly Drawing	21
17.0	TROUBLE SHOOTING – ELECTRICAL	22
18.0	CHECK LIST CD-212 SYSTEM P.N. 100-0112	24
19.0	CHECK LIST CD-212 SYSTEM P.N. 100-0113	24

LIST OF FIGURES

1	CD CONTACT PROCESS	2
2	STRAIGHT POLARITY HOOK-UP	4
3	REVERSE POLARITY HOOK-UP	5
4	FRONT PANEL LAYOUT	6
5	STANDARD GUN SETUP	7
6	COLLET PROTECTOR SETUP	8
7	TEMPLATE ADAPTER GUN SETUP	9
8	COLLET PROTECTOR/BLUNT LEG SETUP	9
9	LIGHT DUTY CD GUN	14
10	HOT WELD	17
11	COLD WELD	17
12	ARC BLOW	18
13	WELD WITHOUT FOOTPIECE	18
14	GOOD WELD	18
15	PARTS LIST	19
16	PARTS LIST (continued)	20
17	PC BOARD	21

SECTION 1 – SAFETY PRECAUTIONS - READ BEFORE USING

1-1. Symbol Usage



Means Warning! Watch Out! There are possible hazards with this procedure! The possible hazards are shown in the adjoining symbols.

▲ Marks a special safety message.

☞ Means "Note"; not safety related.



This group of symbols means Warning! Watch Out! possible ELECTRIC SHOCK, MOVING PARTS, and HOT PARTS hazards. Consult symbols and related instructions below for necessary actions to avoid the hazards.

1-2. Arc Welding Hazards

▲ The symbols shown below are used throughout this manual to call attention to and identify possible hazards. When you see the symbol, watch out, and follow the related instructions to avoid the hazard. The safety information given below is only a summary of the more complete safety information found in the Safety Standards listed in Section NO TAG. Read and follow all Safety Standards.

▲ Only qualified persons should install, operate, maintain, and repair this unit.

▲ During operation, keep everybody, especially children, away.



ELECTRIC SHOCK can kill.

Touching live electrical parts can cause fatal shocks or severe burns. The electrode and work circuit is electrically live whenever the output is on. The input power circuit and machine internal circuits are also live when power is on. In semiautomatic or automatic wire welding, the wire, wire reel, drive roll housing, and all metal parts touching the welding wire are electrically live. Incorrectly installed or improperly grounded equipment is a hazard.

- Do not touch live electrical parts.
- Wear dry, hole-free insulating gloves and body protection.
- Insulate yourself from work and ground using dry insulating mats or covers big enough to prevent any physical contact with the work or ground.
- Do not use AC output in damp areas, if movement is confined, or if there is a danger of falling.
- Use AC output ONLY if required for the welding process.
- If AC output is required, use remote output control if present on unit.
- Disconnect input power or stop engine before installing or servicing this equipment. Lockout/tagout input power according to OSHA 29 CFR 1910.147 (see Safety Standards).
- Properly install and ground this equipment according to its Owner's Manual and national, state, and local codes.
- Always verify the supply ground – check and be sure that input power cord ground wire is properly connected to ground terminal in disconnect box or that cord plug is connected to a properly grounded receptacle outlet.
- When making input connections, attach proper grounding conductor first – double-check connections.
- Frequently inspect input power cord for damage or bare wiring – replace cord immediately if damaged – bare wiring can kill.
- Turn off all equipment when not in use.
- Do not use worn, damaged, undersized, or poorly spliced cables.
- Do not drape cables over your body.

- If earth grounding of the workpiece is required, ground it directly with a separate cable – do not use work clamp or work cable.
- Do not touch electrode if you are in contact with the work, ground, or another electrode from a different machine.
- Use only well-maintained equipment. Repair or replace damaged parts at once. Maintain unit according to manual.
- Wear a safety harness if working above floor level.
- Keep all panels and covers securely in place.
- Clamp work cable with good metal-to-metal contact to workpiece or worktable as near the weld as practical.
- Insulate work clamp when not connected to workpiece to prevent contact with any metal object.
- Do not connect more than one electrode or work cable to any single weld output terminal.

SIGNIFICANT DC VOLTAGE exists after removal of input power on inverters.

- Turn Off inverter, disconnect input power, and discharge input capacitors according to instructions in Maintenance Section before touching any parts.



FUMES AND GASES can be hazardous.

Welding produces fumes and gases. Breathing these fumes and gases can be hazardous to your health.

- Keep your head out of the fumes. Do not breathe the fumes.
- If inside, ventilate the area and/or use exhaust at the arc to remove welding fumes and gases.
- If ventilation is poor, use an approved air-supplied respirator.
- Read the Material Safety Data Sheets (MSDSs) and the manufacturer's instructions for metals, consumables, coatings, cleaners, and degreasers.
- Work in a confined space only if it is well ventilated, or while wearing an air-supplied respirator. Always have a trained watchperson nearby. Welding fumes and gases can displace air and lower the oxygen level causing injury or death. Be sure the breathing air is safe.
- Do not weld in locations near degreasing, cleaning, or spraying operations. The heat and rays of the arc can react with vapors to form highly toxic and irritating gases.
- Do not weld on coated metals, such as galvanized, lead, or cadmium plated steel, unless the coating is removed from the weld area, the area is well ventilated, and if necessary, while wearing an air-supplied respirator. The coatings and any metals containing these elements can give off toxic fumes if welded.



ARC RAYS can burn eyes and skin.

Arc rays from the welding process produce intense visible and invisible (ultraviolet and infrared) rays that can burn eyes and skin. Sparks fly off from the weld.

- Wear a welding helmet fitted with a proper shade of filter to protect your face and eyes when welding or watching (see ANSI Z49.1 and Z87.1 listed in Safety Standards).
- Wear approved safety glasses with side shields under your helmet.
- Use protective screens or barriers to protect others from flash and glare; warn others not to watch the arc.
- Wear protective clothing made from durable, flame-resistant material (leather and wool) and foot protection.



WELDING can cause fire or explosion.

Welding on closed containers, such as tanks, drums, or pipes, can cause them to blow up. Sparks can fly off from the welding arc. The flying sparks, hot workpiece, and hot equipment can cause fires and burns. Accidental contact of electrode to metal objects can cause sparks, explosion, overheating, or fire. Check and be sure the area is safe before doing any welding.

- Protect yourself and others from flying sparks and hot metal.
- Do not weld where flying sparks can strike flammable material.
- Remove all flammables within 35 ft (10.7 m) of the welding arc. If this is not possible, tightly cover them with approved covers.
- Be alert that welding sparks and hot materials from welding can easily go through small cracks and openings to adjacent areas.
- Watch for fire, and keep a fire extinguisher nearby.
- Be aware that welding on a ceiling, floor, bulkhead, or partition can cause fire on the hidden side.
- Do not weld on closed containers such as tanks, drums, or pipes, unless they are properly prepared according to AWS F4.1 (see Safety Standards).
- Connect work cable to the work as close to the welding area as practical to prevent welding current from traveling long, possibly unknown paths and causing electric shock and fire hazards.
- Do not use welder to thaw frozen pipes.
- Remove stick electrode from holder or cut off welding wire at contact tip when not in use.
- Wear oil-free protective garments such as leather gloves, heavy shirt, cuffless trousers, high shoes, and a cap.
- Remove any combustibles, such as a butane lighter or matches, from your person before doing any welding.

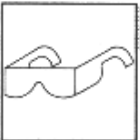

FLYING METAL can injure eyes.

- Welding, chipping, wire brushing, and grinding cause sparks and flying metal. As welds cool, they can throw off slag.
- Wear approved safety glasses with side shields even under your welding helmet.



BUILDUP OF GAS can injure or kill.

- Shut off shielding gas supply when not in use.
- Always ventilate confined spaces or use approved air-supplied respirator.



HOT PARTS can cause severe burns.

- Do not touch hot parts bare handed.
- Allow cooling period before working on gun or torch.



MAGNETIC FIELDS can affect pacemakers.

- Pacemaker wearers keep away.
- Wearers should consult their doctor before going near arc welding, gouging, or spot welding operations.



NOISE can damage hearing.

Noise from some processes or equipment can damage hearing.

- Wear approved ear protection if noise level is high.



CYLINDERS can explode if damaged.

Shielding gas cylinders contain gas under high pressure. If damaged, a cylinder can explode. Since gas cylinders are normally part of the welding process, be sure to treat them carefully.

- Protect compressed gas cylinders from excessive heat, mechanical shocks, slag, open flames, sparks, and arcs.
- Install cylinders in an upright position by securing to a stationary support or cylinder rack to prevent falling or tipping.
- Keep cylinders away from any welding or other electrical circuits.
- Never drape a welding torch over a gas cylinder.
- Never allow a welding electrode to touch any cylinder.
- Never weld on a pressurized cylinder – explosion will result.
- Use only correct shielding gas cylinders, regulators, hoses, and fittings designed for the specific application; maintain them and associated parts in good condition.
- Turn face away from valve outlet when opening cylinder valve.
- Keep protective cap in place over valve except when cylinder is in use or connected for use.
- Read and follow instructions on compressed gas cylinders, associated equipment, and CGA publication P-1 listed in Safety Standards.

1-3. Additional Symbols for Installation, Operation, and Maintenance



FIRE OR EXPLOSION hazard.

- Do not install or place unit on, over, or near combustible surfaces.
- Do not install unit near flammables.
- Do not overload building wiring – be sure power supply system is properly sized, rated, and protected to handle this unit.



MOVING PARTS can cause injury.

- Keep away from moving parts such as fans.
- Keep all doors, panels, covers, and guards closed and securely in place.



FALLING UNIT can cause injury.

- Use lifting eye to lift unit only, NOT running gear, gas cylinders, or any other accessories.
- Use equipment of adequate capacity to lift and support unit.
- If using lift forks to move unit, be sure forks are long enough to extend beyond opposite side of unit.



H.F. RADIATION can cause interference.

- High-frequency (H.F.) can interfere with radio navigation, safety services, computers, and communications equipment.
- Have only qualified persons familiar with electronic equipment perform this installation.
- The user is responsible for having a qualified electrician promptly correct any interference problem resulting from the installation.
- If notified by the FCC about interference, stop using the equipment at once.
- Have the installation regularly checked and maintained.
- Keep high-frequency source doors and panels tightly shut, keep spark gaps at correct setting, and use grounding and shielding to minimize the possibility of interference.



OVERUSE can cause OVERHEATING

- Allow cooling period; follow rated duty cycle.
- Reduce current or reduce duty cycle before starting to weld again.
- Do not block or filter airflow to unit.



STATIC (ESD) can damage PC boards.

- Put on grounded wrist strap BEFORE handling boards or parts.
- Use proper static-proof bags and boxes to store, move, or ship PC boards.



MOVING PARTS can cause injury.

- Keep away from moving parts.
- Keep away from pinch points such as drive rolls.



WELDING WIRE can cause injury.

- Do not press gun trigger until instructed to do so.
- Do not point gun toward any part of the body, other people, or any metal when threading welding wire.



ARC WELDING can cause interference.

- Electromagnetic energy can interfere with sensitive electronic equipment such as computers and computer-driven equipment such as robots.
- Be sure all equipment in the welding area is electromagnetically compatible.
- To reduce possible interference, keep weld cables as short as possible, close together, and down low, such as on the floor.
- Locate welding operation 100 meters from any sensitive electronic equipment.
- Be sure this welding machine is installed and grounded according to this manual.
- If interference still occurs, the user must take extra measures such as moving the welding machine, using shielded cables, using line filters, or shielding the work area.

1-4. Principal Safety Standards

Safety in Welding and Cutting, ANSI Standard Z49.1, from American Welding Society, 550 N.W. LeJeune Rd, Miami FL 33126

Safety and Health Standards, OSHA 29 CFR 1910, from Superintendent of Documents, U.S. Government Printing Office, Washington, D.C. 20402.

Recommended Safe Practices for the Preparation for Welding and Cutting of Containers That Have Held Hazardous Substances, American Welding Society Standard AWS F4.1, from American Welding Society, 550 N.W. LeJeune Rd, Miami, FL 33126

National Electrical Code, NFPA Standard 70, from National Fire Protection Association, Batterymarch Park, Quincy, MA 02269.

Safe Handling of Compressed Gases in Cylinders, CGA Pamphlet P-1, from Compressed Gas Association, 1235 Jefferson Davis Highway, Suite 501, Arlington, VA 22202.

Code for Safety in Welding and Cutting, CSA Standard W117.2, from Canadian Standards Association, Standards Sales, 178 Rexdale Boulevard, Rexdale, Ontario, Canada M9W 1R3.

Safe Practices For Occupation And Educational Eye And Face Protection, ANSI Standard Z87.1, from American National Standards Institute, 1430 Broadway, New York, NY 10018.

Cutting And Welding Processes, NFPA Standard 51B, from National Fire Protection Association, Batterymarch Park, Quincy, MA 02269.

1-5. EMF Information

Considerations About Welding And The Effects Of Low Frequency Electric And Magnetic Fields

Welding current, as it flows through welding cables, will cause electromagnetic fields. There has been and still is some concern about such fields. However, after examining more than 500 studies spanning 17 years of research, a special blue ribbon committee of the National Research Council concluded that: "The body of evidence, in the committee's judgment, has not demonstrated that exposure to power-frequency electric and magnetic fields is a human-health hazard." However, studies are still going forth and evidence continues to be examined. Until the final conclusions of the research are reached, you may wish to minimize your exposure to electromagnetic fields when welding or cutting.

To reduce magnetic fields in the workplace, use the following procedures:

1. Keep cables close together by twisting or taping them.
2. Arrange cables to one side and away from the operator.
3. Do not coil or drape cables around your body.
4. Keep welding power source and cables as far away from operator as practical.
5. Connect work clamp to workpiece as close to the weld as possible.

About Pacemakers:

Pacemaker wearers consult your doctor first. If cleared by your doctor, then following the above procedures is recommended.

1.0 INTRODUCTION

Your new stud welding equipment is carefully constructed of the finest components and materials available. Used properly, this equipment will give you years of profitable, efficient service.

The system incorporates the latest in engineering advances, for completely reliable end welding of mild steel, stainless steel, aluminum and lead free copper and brass fasteners.

A careful study of this manual will enable you to understand how the welder operates to insure proper performance under all operating conditions.

2.0 WARRANTY

The electrical and mechanical components of the stud welder are thoroughly performance inspected prior to assembly in the welder. The assembled welder is completely performance checked. The welder is delivered to you in functional electro-mechanical condition.

All parts used in the assembly of the welder and its accessories are fully warranted for a period of 1 YEAR from the date of delivery. In addition, the welding capacitors are warranted for a period of 1 YEAR from the date of delivery. The printed circuit boards used in all pro weld equipment are warranted for a period of 3 years.

Under the warranty, the manufacturer reserves the right to repair or replace, at their option, defective parts which fail during the guarantee period. Notice of any claim for warranty repair or replacement must be furnished to the manufacturer by the purchaser within ten (10) days after the defect is first discovered. The manufacturer does not assume any liability for paying shipping cost or any labor or materials furnished where such cost are not expressly authorized in writing.

The manufacturer does not warrant any parts or accessories against failures resulting from misuse, abuse, improper installation, maladjustment, or use not in accordance with the operating instructions furnished by the manufacturer. The warranty is valid only when studs are purchased from sources approved by the manufacturer or are of identical specifications to the manufacturer's

3.0 UNPACKING YOUR UNIT

Upon receipt of your unit, place it as close as possible to the point of installation before unpacking it. Do not operate the unit from an extension power cord if possible. Once the unit is unpacked it is recommended that you inspect it for any physical damage.

Your unit has been completely assembled and inspected at the factory. Upon receipt, the unit must be hooked up to the recommended incoming power before welding. We recommend that you check that you have received all the items listed on the shipping check list. (see SECTION 18 or 19)

Place the unit in a large enough area to provide adequate ventilation. Do not restrict the air flow through the side louvers. Do not allow water to enter the control housing.

4.0 SUGGESTED SAFETY PRECAUTIONS

In any welding operation, it is the responsibility of the welder to observe certain safety rules to insure his personal safety and to protect those working near him.

Reference is directed, without endorsement or recommendation, to ANSI Z49.1, Safety in Welding and Cutting, and to AWG Publication A6.1-66, Recommended Safety Practices for Gas-Shield Arc Welding.

1. Always treat electricity with respect. Under open circuit conditions, the welding machine output voltage may be dangerous.
2. Don't work on live circuits or conductors. Disconnect the main power line before checking the machine or performing any maintenance operations.
3. Be sure the welding machine cabinet is properly grounded to a good electrical ground.
4. Don't stand in water or on a damp floor while welding or weld in the rain. Avoid wearing wet sweaty cloths when welding.

5. Don't operate with worn or poorly connected cables. Don't operate weld gun with loose cable connections. Inspect all cables frequently for insulation failures, exposed wires, loose connections, and repair as needed.
6. Don't overload welding cables or continue to operate with hot cables.
7. Don't weld near flammable materials or liquids, in or near atmospheres, or on ducts carrying explosive gases.
8. Don't weld on containers which have held combustible or flammable materials, or on materials which give off flammable or toxic vapors when heated, without proper cleaning, purging, or inerting.
9. Be sure to provide for proper ventilation when welding in confined spaces.
10. Never look at the electric arc without wearing protective eye shields.
11. Always use the proper protective clothing, gloves, ect.
12. Never strike an arc when near a bystander who is unaware of the dangers of ultraviolet light on their eyes.

5.0 GENERAL DESCRIPTION

CD-212 HEAVY DUTY PORTABLE CD STUD/PIN WELDER

The CD-212 portable CD welder is a self contained heavy duty capacitor discharge power supply capable of welding up to 1/4" flanged studs in mild steel.

The CD-212 utilizes a solid state control board for longer life and has been designed for easy maintenance and field service. This welder uses standard 110 volt AC line voltage.

The system comes complete with power cord, weld cables and gun. Just add the accessories required for the stud size to be welded. This manual should provide all the information required for you to be able to set up, weld, and maintain the CD-212 welding system.

6.0 THE CD WELDING PROCESS

Contact welding is the simplest and most common method of CD stud welding. Practically foolproof, it produces no reverse side marking in most cases and is suitable for most commercial and industrial applications.

First, the gun must be set-up with the proper accessories for the length and diameter stud you are going to weld. Refer to the CD Accessories Guide and CD Stud Welding Gun Section for information on accessories and gun set-up.

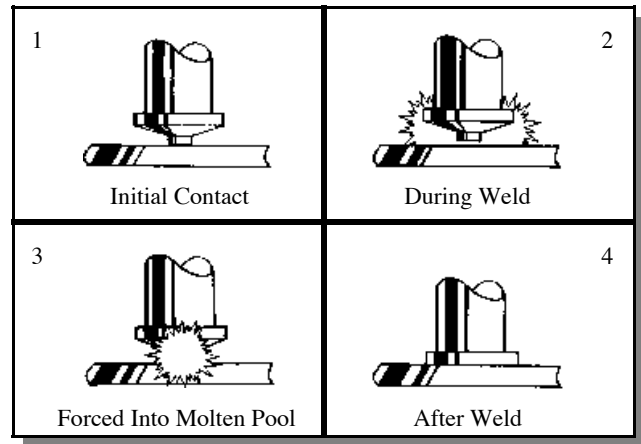

(FIGURE 1 CONTACT CD WELD)

The stud is first placed in contact with the base material (SEE FIGURE 1). Verify that the gun is held perpendicular to the work. Pulling the trigger discharges the capacitors through the stud which vaporizes the tip. The proper tip design is critical. This is what determines the length of time of the weld. An arc is briefly sustained which melts the stud base surface and the work surface directly underneath the stud. The spring pressure in the gun then forces the stud into the molten pool, completing the weld in approximately six milliseconds.

This technique, when equipment is set up properly, is simple and easily mastered. The same power supply is capable of welding many different sizes and materials of fasteners. If you require assistance in selecting the proper accessories, contact our customer service department or your field representative.

7.0 POWER REQUIREMENTS

110 VOLT OPERATION

110 volt AC 60 H: 20 amps;
Circuit protection: 15 amp circuit breaker
(P/N: 104-0020)

Integral 9 foot power cord
IF EXTENSION REQUIRED

Cable Length	110 Volt
12'	#16/3
25'	#16/3
30'	#14/3
50'	#12/3

8.0 SYSTEM SPECIFICATIONS

Weight:

26 Lbs.

Size:

9" W x 11 3/4" D x 8 1/2" H
22.9 cm W x 29.8 cm D x 21.6 cm H

Chassis:

14 Ga. Aluminum (Painted International Orange)

Panel Controls:

Power
Voltage Controls

Weldable Materials:

Steel, Stainless steel, Aluminum, Copper, Brass, Zinc coated, Galvanized

Weldable Stud Diameter:

14 Ga. Through 1/4" Flanged
(Max W.B. Dia. For AL=5/16" (1/4" thread)

Weld Rate:

12 per minute

Weld Voltage:

45-200 VDC

Weld Mode:

Contact

Polarity:

Straight or Reverse

Power Required:

110 Volt AC 60 Hz 20 Amp

Circuit Protection:

15 Amp circuit breaker
3AG 1 Amp 250 volt fuses
(2 on PC Board)

STANDARD GUN & CABLE SPECIFICATIONS

WELD GUN-LIGHT DUTY PRECISION
CD CONTACT

Part Number:

300-0100 B Collet Gun
300-0101 Taper Tip Gun

Weight:

2 lbs. (not including cable)
(lbs. (including 25 ft. #4 weld cable & 16-4 SOW control cable)

Size:

6 1/2" x 5 3/4" x 2"

Weldable Stud Diameter:

14 Ga. Through 1/4" Flanged

Material:

High strength, impact resistant, glass fiber reinforced polycarbonate

Integral Gun Cable Length:

25 feet - #4 AWG

Connectors:

Male Camlok / 2 Pin Hubbell Male

Cables

Ground Cable:

(1) #4 x 15' (P/N: 125-0100)

9.0 WELDING SYSTEM HOOK-UP

9.1 Straight Polarity (Standard Set-Up) (see Figure 2)

A. Connect ground cable connector (1A) into camlok (1). The camlok should be connected into the receptacle marked GROUND. Twist until it locks. Attach “C” clamp (2) to the workpiece (5) (CLEANED AREA).

B. Connect the gun control cable (3A) into the female receptacle (3).

C. Connect the gun weld cable (4A) into the receptacle marked GUN (4). Twist clockwise until it locks.

D. Connect AC power cable to AC outlet.

NOTE:

The gun welding and control cables must be laid out in a straight line. Poor weld quality may result if welding cables are coiled.

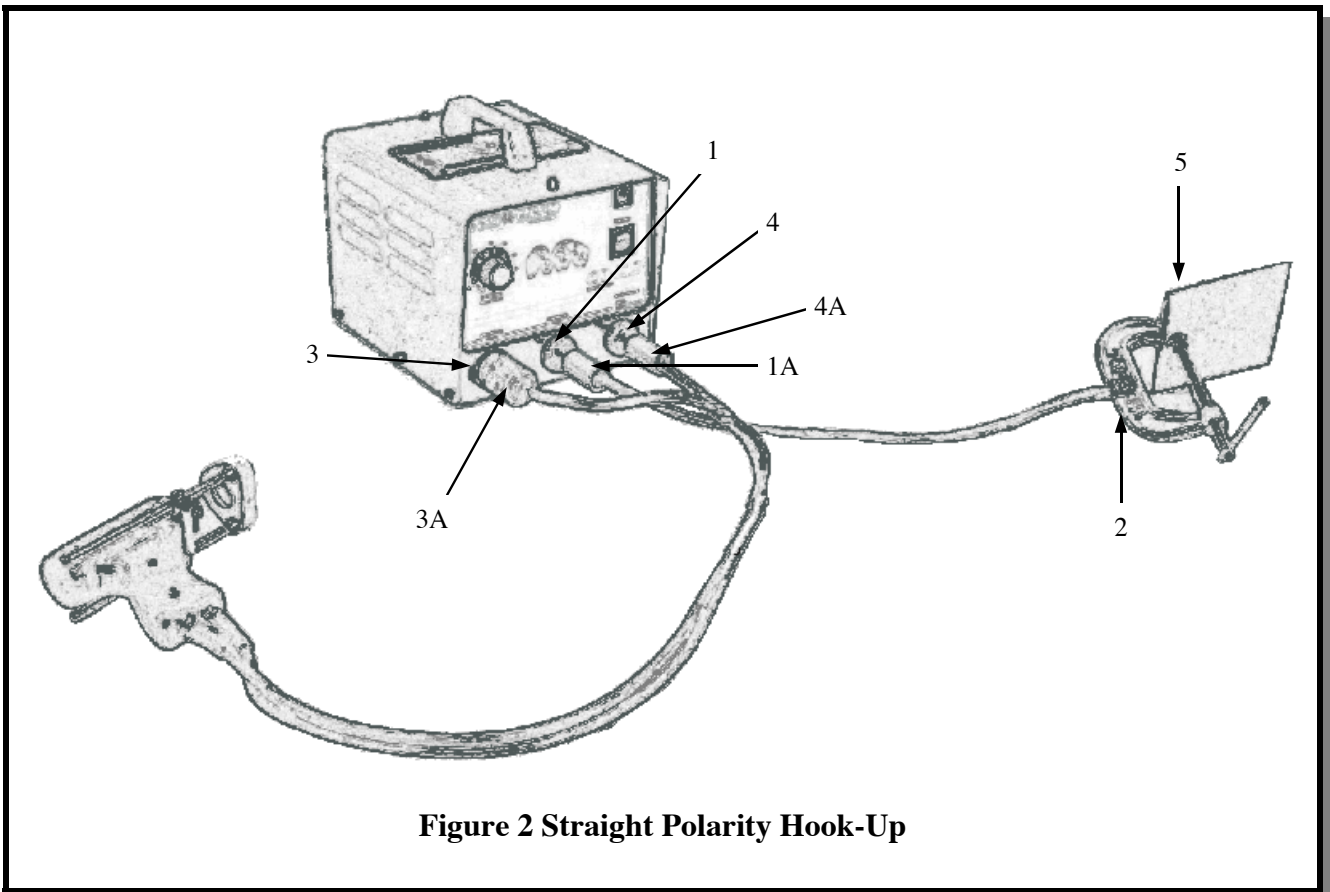

Figure 2 Straight Polarity Hook-Up

9.2 Reverse Polarity (Recommended for brass or galvanized) (see Figure 3)

A. Connect ground cable connector (1A) into camlok (4). The camlok should be connected into the receptacle marked GUN. Twist until it locks. Attach “C” clamp (2) to the workpiece (5) (CLEANED AREA).

B. Connect the gun control cable (3A) into the female receptacle (3).

C. Connect the gun weld cable (4A) into the receptacle marked GROUND (1). Twist clockwise until it locks.

D. Connect AC power cable to AC outlet.

NOTE:

The gun welding and control cables must be laid out in a straight line. Poor weld quality may result if welding cables are coiled.

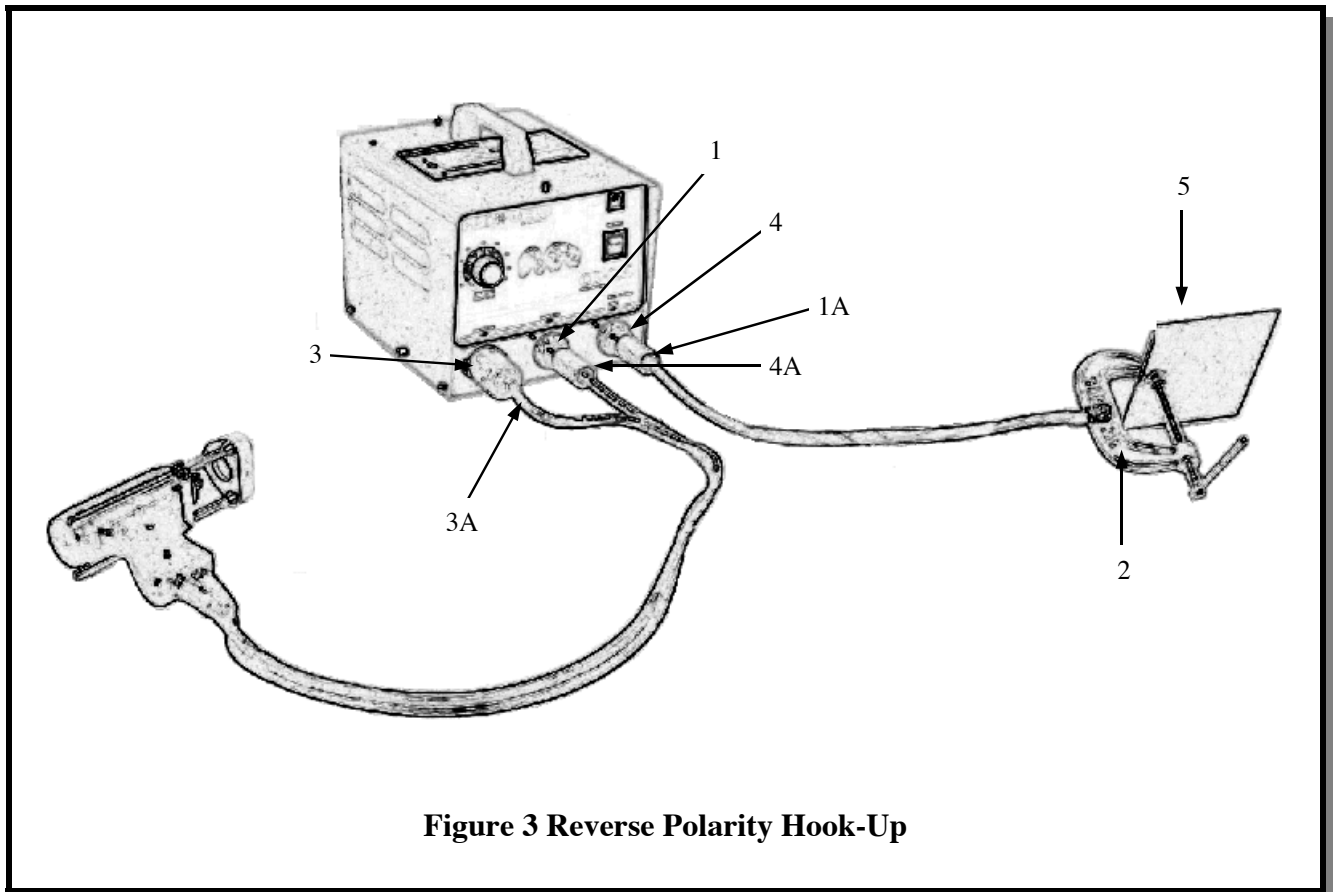

10.0 SYSTEM OPERATION

(see Figure 4)

1. The CD-212 is designed for simple, yet precise operation.
2. It has an “ON-OFF” rocker switch/indicator light (1) and a variable voltage control dial (2) on the front panel.
3. Before turning the unit “ON”, the voltage control knob (2) should be turned counter-clockwise to the lowest setting.
4. With all cables connected, turn the unit on by putting the rocker switch (1) in the “ON” position. The integral indicator light (1) will turn on.

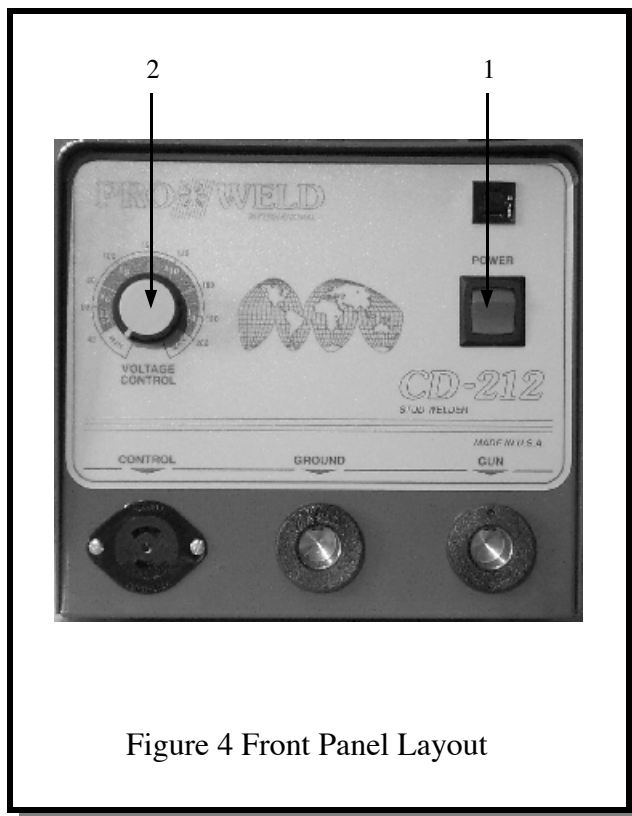

Figure 4 Front Panel Layout

Setting the Weld Voltage/Capacitance

Slowly turn the voltage control knob clockwise to increase the weld voltage until the indicator knob is pointing at the appropriate number for the particular stud size that you are welding. (See the set up information chart, Below).

NOTE:

Once the voltage control knob is set to a higher setting, turning it counter-clockwise will NOT reduce the voltage on the capacitor bank, until the toggle switch (1) is turned “OFF” (for approximately 10 seconds).

The settings are marked with the voltages corresponding to various stud sizes. The approximate voltages for each stud size is as follows:

45 VDC	Min.
45-80 VDC	12 ga./#6
80-120 VDC	#8
120-160 VDC	#10
160-190 VDC	1/4"
200VDC	MAX.

11.0 GUN SET-UP

11.1 STANDARD (see Figure 5)

The standard gun set-up is used for welding the majority of applications. It consists of the standard adjustable face plate, two legs, a foot, B-collet, stop, and spring for your specific stud size.

A step-by-step explanation of the correct way to set-up and operate the standard CD gun.

To prepare for stud welding, it is necessary to have the proper accessories for the stud to be welded. Those required are the legs, footpiece, spring, collet, and appropriate screws and washers. A 3/32" and a 5/32" hex wrench are the only tools needed for the adjustment of the gun.

For CD welding, the stud normally should be engaged for all but 1/4" of its length, whenever possible. Selecting the proper stop will accomplish this for you. The objective of the collet is to maintain a firm grip on the fastener to assure correct alignment and a good electrical connection, yet allow for ease of loading.

Once the selection of the correct accessory is made, assembly may begin. The footpiece is mounted on the legs using 10-32 x 3/4" socket head cap screws, inserted through the holes at the base of the footpiece. These holes are recessed so that the head of the screws will not protrude.

After assembling the legs and footpiece, insert the collet and stop into the open end of the gun shaft. Secure the collet in place with two set screws on the shaft. Locate the legs, with footpiece attached, in the

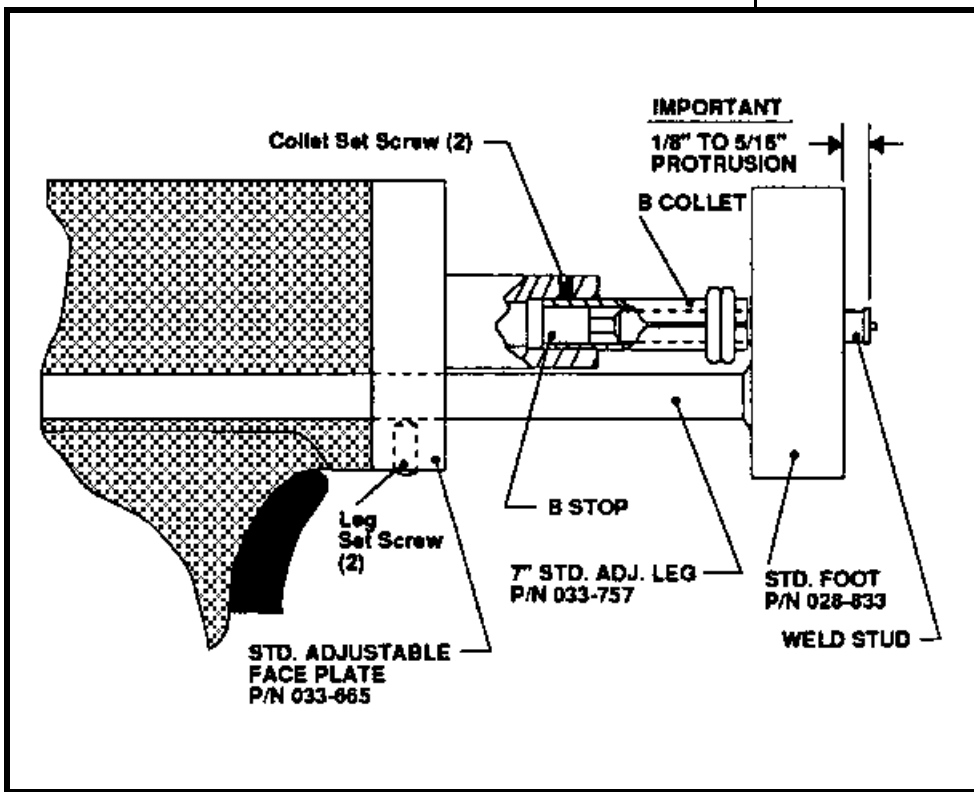

holes provided in the gun faceplate. (It may be necessary to back off the socket screw in the faceplate to allow the legs to enter the hole). Center the opening of the footpiece around the weld end of the fastener. Tighten the footpiece in position at this time. Adjustment for the plunge which is the distance the stud protrudes beyond the end of the footpiece can now be made. This is done by loosening the two 10-32 x 1/4" set screws at the bottom of the faceplate using the 3/32" Allen wrench. Then sliding the legs for proper adjustment. Refer to the set-up chart for correct plunge distance (from 1/8" to 5/16").

NOTE:

Correct set-up on all CD units is 1/8"-5/16" plunge. This must be assured for proper weld results in all cases.

Figure 5 Standard Gun Setup

The gun is now ready to weld. Select the proper setting for the size stud to be welded. Voltage is determined by the weld base diameter. Be sure your power source is set for the proper polarity: straight for steel, reverse for galvanized.

11.2 INSTALLING OR CHANGING COLLETS OR CHUCKS

(The terms collet or chuck are different names for the same device). The collet holds the pin or stud to be welded. It is secured to the gun shaft by two set screws. These screws are loosened to remove or replace a collet. Tighten these screws snugly to secure the collet in place.

When you change the size of the stud you are welding, you must also change to the appropriate collet. If a collet becomes damaged or broken, it must be replaced. You may also need a stop.

11.3 GUN SET-UP FOR WELD PINS WITH COLLET PROTECTOR (see Figure 6)

The collet protector has several advantages over the standard set-up.

1. It does not require a pin stop. therefore, the same setup is applicable for a range of pin lengths.
2. There is a fixed plunge, no gun adjustments necessary.
3. It provides stability at the weld end of the pin.

There are two standard sizes available: 12 ga. And 10 ga. It is used with the round faceplate and three blunt legs. The collet protector slides over the collet and fastens to the chuck with three allen set screws. The insert, which takes the place of the Inter- al stop, is replaceable.

The stud is pushed into the chuck until the flange bottoms out on the insert. The collet protector is not available for studs larger than 10 ga.

The standard adjustable legs and footpiece combination can alternately be used with the collet protector as shown in Figure 10.

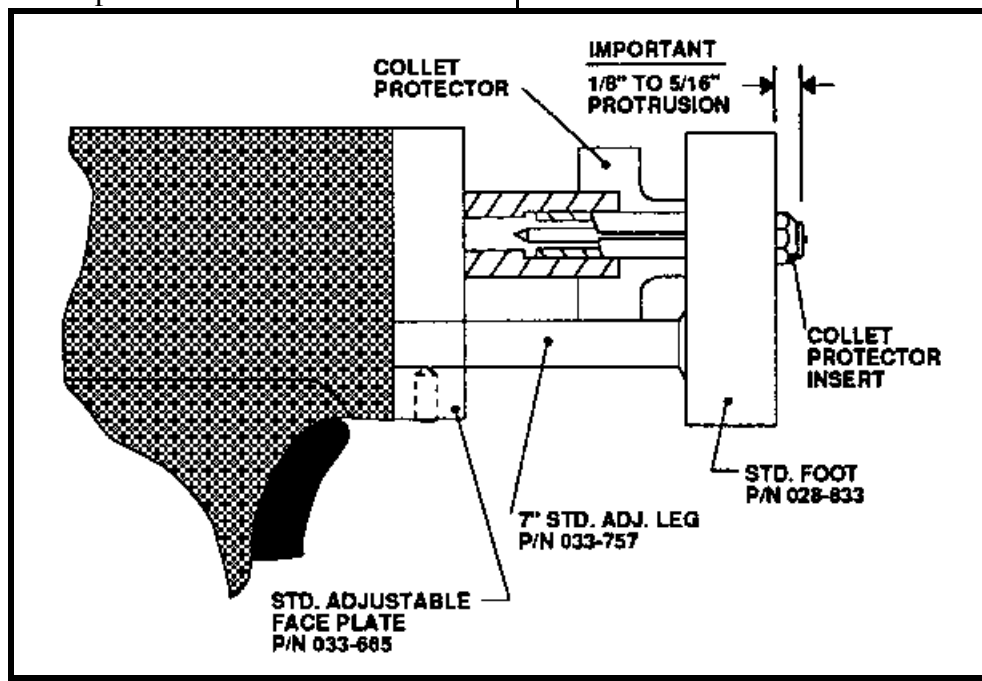

Figure 6 Collet Protector Gun Setup

11.4 TEMPLATE ADAPTER (see Figure 7)

The template adapter is used when precise location or positioning of the CD stud is required. It is used with the round faceplate and does not require a footpiece or legs. The adapter is fastened to the faceplate and provides a fixed distance between the collet and work. The plunge is set by using the correct stop in the collet. A template can then be fabricated to enable very precise locating of a particular stud.

The template adapter is available in two sizes, (1" and 1-1/4" diameter).

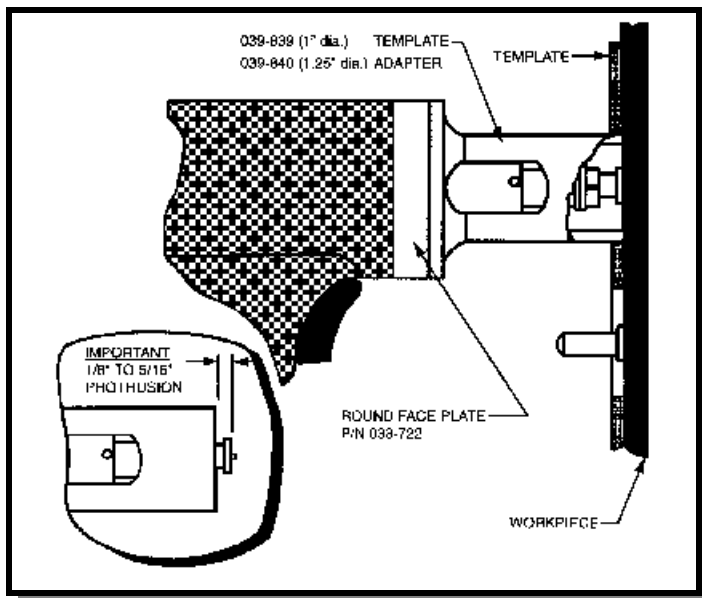

Figure 7 Template Adapter gun setup

11.5 COLLET PROTECTOR/BLUNT LEG (see Figure 8)

The round faceplate, with blunt legs, can alternately be used with the collet protector as shown in Figure 8.

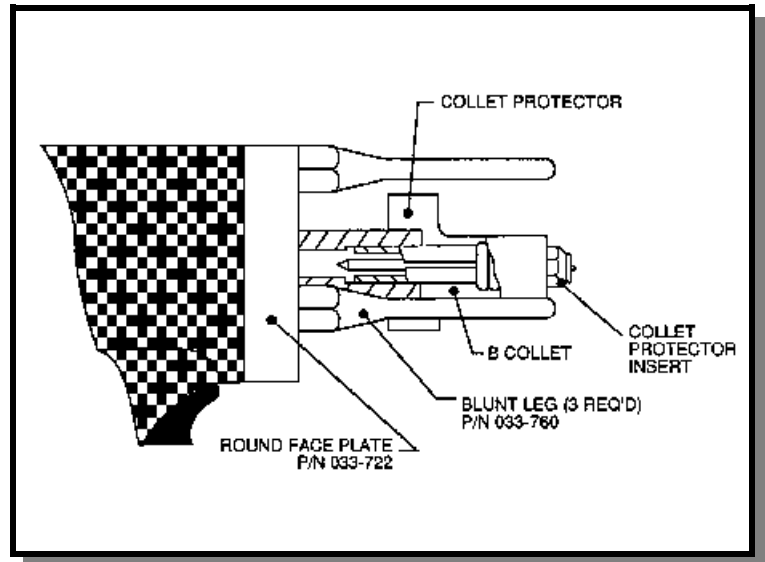
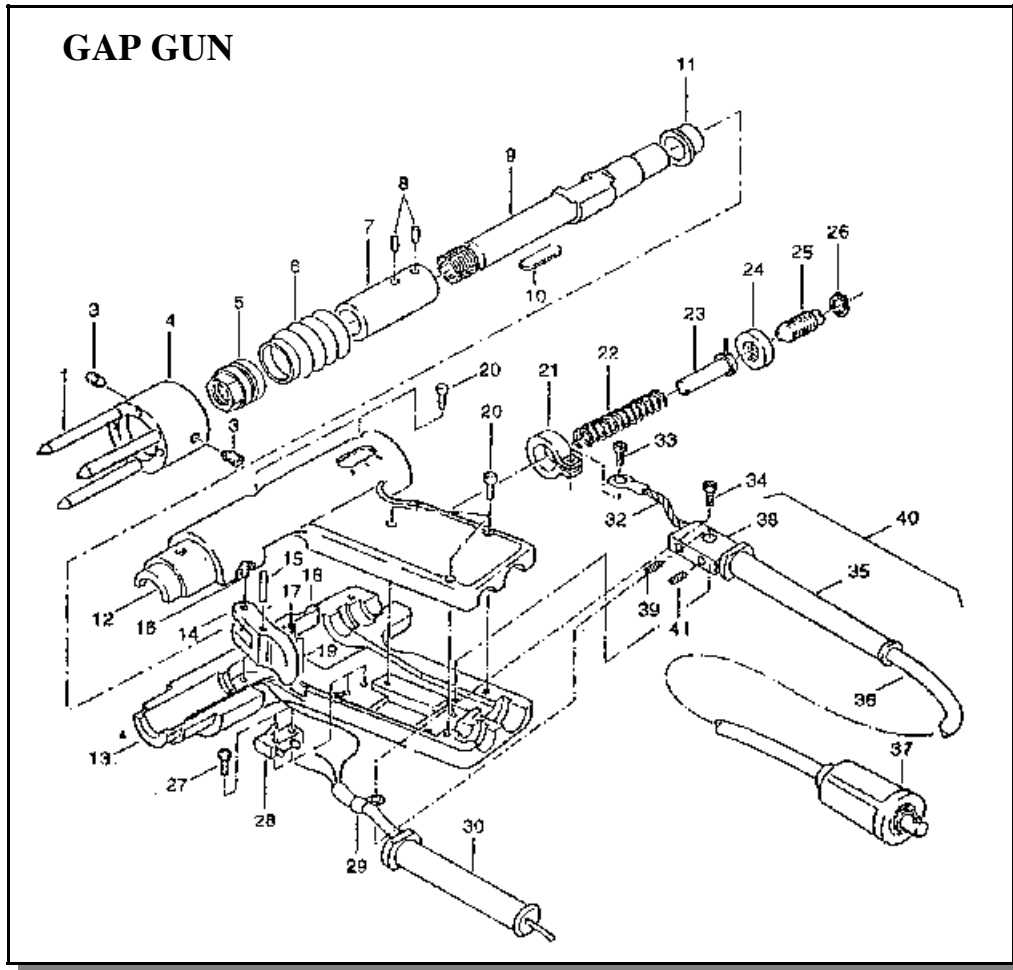

Figure 8 Collet Protector/Blunt Leg Setup



ITEM	PART #	QTY	DESCRIPTION	ITEM	PART #	QTY	DESCRIPTION
1	F01358	3	GROUNDING FOOT	22	F01373	1	PRESSURE SPRING
3	M01797	2	THREAD PIN M6X6	23	F01372	1	SPRING GUIDE
4	F01377	1	FOOT RING	24	F01378	1	SET COLLAR
5	M01375	1	UNION NUT	25	F01379	1	ADJUSTING SCREW
6	F01376	1	RUBBER BELLOW	26	M01371	1	LOCKING RING
7	F01372	1	FINDER SLEEVE	27	M01332	2	CHEESE HEADSCREW M2X10
8	M01329	2	STRAIGHT PIN 3X8	28	E02091	1	MICROSWITCH
9	F01368	1	WORKING PISTON	29	M01387	1	CABLE CLIP
10	F01369	1	FEATHER KEY	30	E02093	1	PROTECTION SLEEVE
11	F01370	1	RELEASE RING	31	E02121	1	COMPLETE CONTROL CABLE
12	F01366	1	PISTOL SHELL LHS	32	F01414/FA	1	GROUND CORD
13	F01367	1	PISTOL SHELL RHS	33	M01087	1	CHEESE HEADSCREW M4X10
14	F01381	1	TRIGGER HANDLE	34	M01085	1	CHEESE HEADSCREW M4X6
15	M01328	1	STRAIGHT PIN 3X18	35	E02082	1	PROTECTION SLEEVE
16	M01325	1	STRAIGHT PIN 3X30	36	E02035	1	GROUND CABLE 25MM
17	F01383	1	PRESSURE SPRING	37	E01963	1	GROUND PLUG
18	F01382	1	RELEASE ARM	38	F01413	1	STRAIN RELIEF
19	M01532	1	STRAIGHT PIN 3X24	39	M01337	1	THREAD PIN M5X6
20	M01386	6	CHEESE HEADSCREW M3X10	40	F01412/FA	1	COMPLETE PISTOL CABLE**
21	F01371	1	CLAMPING RING	41	M02108	1	THREAD PIN M8X8

Adjustment of stud welding gun

Adjustment of stud collet

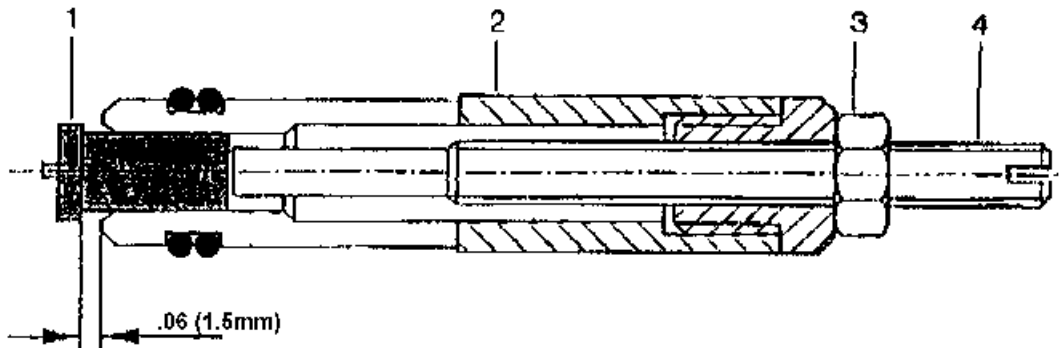

- 1. Stud
- 2. Collet
- 3. Counternut
- 4. Stop Screw

For different stud diameters, different collets are required.

Adjust collet as follows:

- * Loosen counternut (3)
- * Insert stud (1) into collet.
The top edge of the stud flange must project for about .06 (1.5 mm) from the front edge of the collet.

NOTE: The stud must make contact with the stop screw(4).

- * Adjust stop screw (4) in the collet by turning it until the distance from the top edge of the stud flange to the front edge of the collet equals .06 inches (1.5 mm).
- * Lock stop screw (4) by means of counternut (3).
- * The following table indicates which tripod leg length is required.

Stud Length	Leg Length	Part #
0 – 1 3/8	2”(standard)	F01358
1/2 – 1 7/8	2 1/2”	F01359
1 – 2 3/8	3”	F01360
2 – 3 3/8	4”	F01361

Installation of stud collet into stud welding gun

The illustration below shows how to install the stud collet into the stud welding

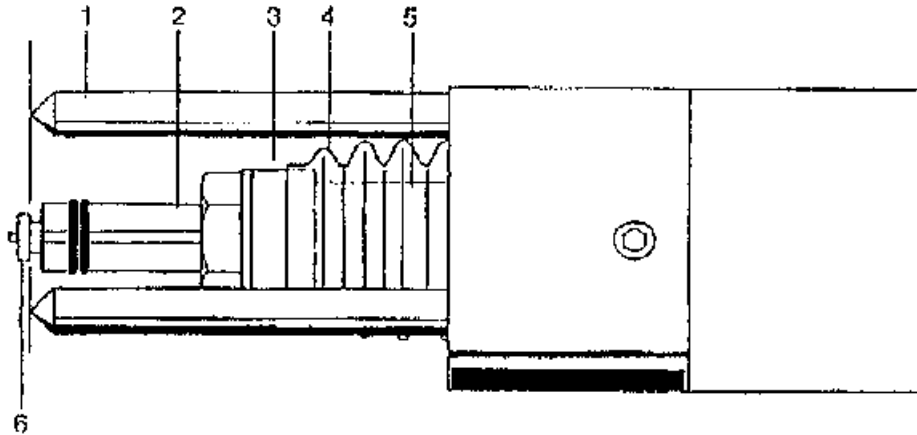

- | | |
|---------------|----------------|
| 1. Tripod leg | 4. Bellow |
| 2. Collet | 5. Gun shaft |
| 3. Sleeve nut | 6. Stud flange |

* Loosen sleeve nut (3) by means of a socket wrench.

* Insert collet (2) into gun shaft (5) until stop

* Tighten collet (2) with sleeve nut (3)

NOTE: The stud flange must project from the top of the tripod legs for the thickness of the flange. If this is not the case, remove collet and correct the projection by means of stop screw.

Adjustment of spring pressure

The pressure with which the stud is pressed against the workpiece during the welding process is called spring pressure.

The following illustration shows how to adjust the spring pressure of stud welding gun which is equipped with a spring pressure indicator.

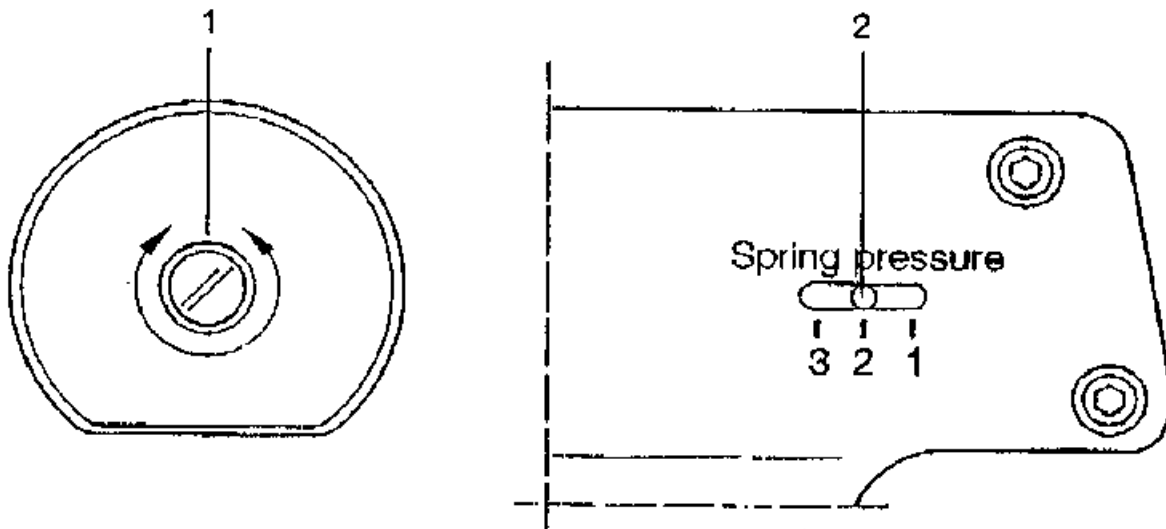

1. Adjusting screw
2. Spring pressure indicator

The spring pressure is adjusted by means of the adjusting screw (1).

The adjusted pressure is indicated at the spring pressure scale (2).

Adjust spring pressure as follows:

- * Turn adjusting screw (1) to the left until stop
Indicator position 1 = low pressure
- * Turn adjusting screw (1) 3.5 turns to the right
Indicator position 2 = medium pressure
- * Turn adjusting screw (1) to the right until stop
Indicator position 3 = high pressure

The spring pressure to be adjusted depends on the material of both welding stud and workpiece.

Before starting the work, carry out some experimental weldings and test them to find out the optimum adjustment.

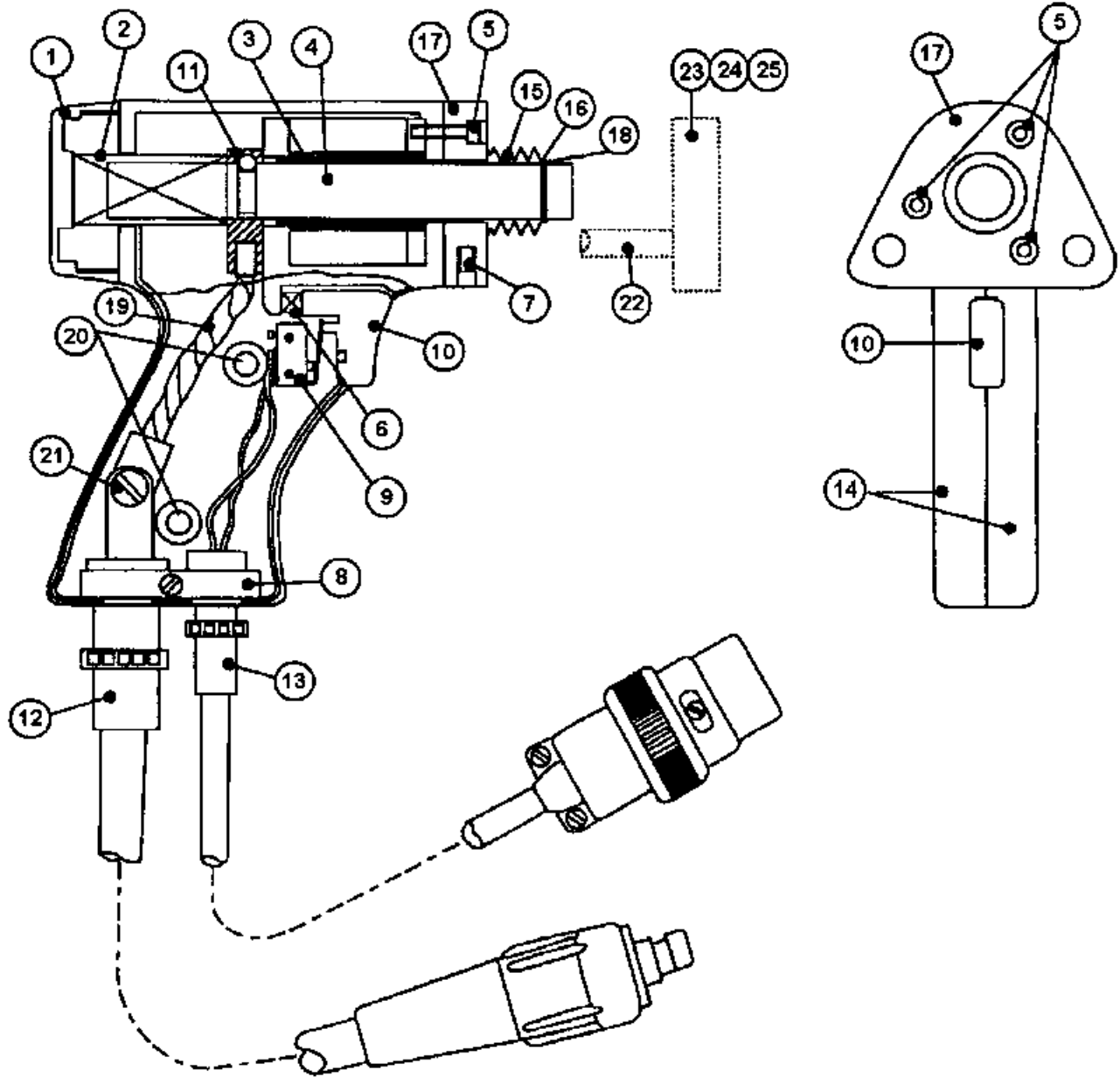

Figure 9 Light Duty CD Gun

11.6 PARTS LIST LIGHT DUTY CD HANDGUN

Part No. 300-0100

ITEM	PART NO.	DESCRIPTION	QTY
1	033-384	GUN (CD) REAR CAP MOLDED	1
2	001-800	SPRING MAIN HEAVY SILVER	1
3	033-610	GUN (CD/DA) BEARING ASSEMBLY	1
4	033-799	GUN (CD) SHAFT TUBE	1
5	033-016	HEX HEAD CAP SCREW	3
6	033-382	GUN (CD/DA/FA) TRIGGER SPRING	1
7	049-955	M SCREW SET MS, BRASS PLT	2
8	NOT USED	GUN (CD/DA/FA) CABLE CLAMP (ALUM. BLOCK)	1
9	033-404	TRIGGER SWITCH	1
10	033-381	GUN (CD/DA/FA) TRIGGER BUTTON MOLDED	1
11	036-496	GUN (FL) SHAFT BLOCK – A	1
12	033-662-25	GUN WELD CABLE (25 FT.)	1
13	033-658-25	GUN CONTROL CABLE (25 FT.)	1
14	033-881	GUN BODY RH & LH STD.CD MACHINED	1
15	033-445	GUN (CD/FL) SHAFT BOOT ASSY	1
16	033-447	GUN (CD) SHAFT BOOT RETAINING RING	1
17	033-665	GUN (CD) FACEPLATE – STD. ADJUSTABLE	1
18	033-446	GUN (CD) SHAFT BOOT SNAP RING	1
19	033-608	GUN (CD) WELD PIGTAIL ASSY	1
20	018-375	SCREW PAN HEAD	2
21	016-876	WASHED, LOCK INTO. TOOTH	1
22	033-757	LEG (CD) STD.ADJ. 7”	2 REF.
23	009-929	FLAT WASHER	2 REF.
24	016-378	SOCKET HEAD CAP SCREW	2 REF.
25	028-833	STD. FOOTPIECE	1 REF.

12.0 WELDABLE MATERIAL COMBINATIONS

BASE MATERIAL	STUD MATERIALS
Mild Steel (1008-1018)	Mild Steel 1008, 1018 Stainless Steel 304, 305 Brass 65-35, 70-30 Copper, Silicon/Bronze
Galvanized Sheet (duct-”Q” Decking)	Mild Steel 1008-1018 Stainless Steel 304,305
Structural Steel (Must Be Clean)	Mild Steel 1008,1018 Stainless Steel 304,305 Brass 65-35, 70-30
Aluminum – Most alloys of the 1100, 3000 and 5000 series.	Aluminum 1100,5356
Zinc Alloys (Die Cast)	Aluminum 1100, 5356
Medium Carbon Steel (1030-1018)	Mild Steel 1008, 1018 Stainless Steel 304,305 Brass 65-35, 70-30
Lead Free Brass Lead Free Rolled Brass Electrolytic Copper	Mild Steel 1008, 1018 Stainless Steel 304, 305 Copper, Silicon/Bronze

13.0 CAUSE OF POOR OR ERRATIC WELDS

1. Loose collet. Does not grip stud tightly. (REPLACE) Not enough engagement of stud to collet. (CHANGE STOP)
2. Fault or loose ground connection. (REPAIR OR TIGHTEN)
3. Poor surface condition of base material, excessive oil, grease, rust, ect. (CLEAN)
4. Voltage or capacitance setting too low or too high. (ADJUST TO DIAMETER OF STUD)
5. Broken or loose cables. (REPAIR)
6. Dirt in gun. (CLEAN)
7. Incorrect polarity. (CABLES HOOKED-UP WRONG)
8. Use of center punch or deep scribe. (DO NOT USE CENTER PUNCH OR DEEP SCRIBES)
9. Cables too closely coiled.
10. Arc blow is evidenced by “one side” welds. In severe cases there will be no melting under one edge of flange while the opposite side is gouged out or appears excessively hot. The principle cause of arc blow is magnetic field induced by the current flow during the weld. It occurs most often on long, narrow strips of metal or near edges of sheets or plates. In some cases, a change in grounding positions, or two grounds on the work piece, one at each end or edge of work, will correct the problem. For assistance in severe cases, contact your local sales representative.
11. Incorrect plunge setting. (ADJUST TO PROPER SETTING)

12. Incorrect spring. (REPLACE WITH PROPER SPRING)

13. Poor stud quality.

14.0 TROUBLE SHOOTING POOR WELDS

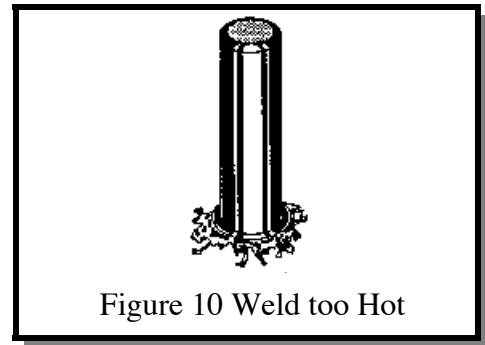

Figure 10 Weld too Hot

Weld too Hot

- A) Decrease voltage.
- B) Decrease capacitance.
- C) Increase stud protrusion.
- D) Increase spring pressure.

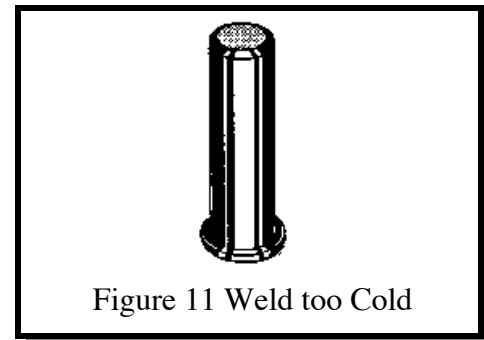

Figure 11 Weld too Cold

Weld too Cold

- A) Increase voltage.
- B) Increase capacitance.
- C) Decrease stud protrusion.
- D) Decrease spring pressure.

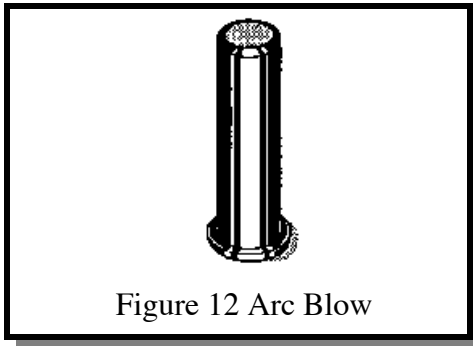

Figure 12 Arc Blow

Arc Blow

- A) Use double grounds.
- B) Ground too close or not spaced

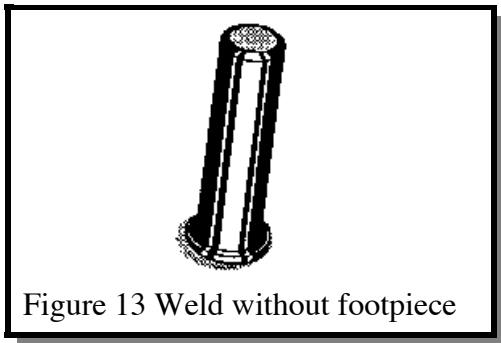

Figure 13 Weld without footpiece

Weld without footpiece

- A) Use standard footpiece.
- B) Use template adapter.
- C) Use tripod blunt legs.

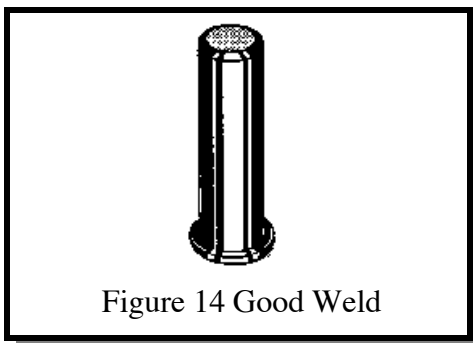

Figure 14 Good Weld

15.0 ROUTINE WELDER MAINTENANCE

Your CD-212 is designed for long service with minimum care. Ordinary common sense maintenance will keep it operating efficiently.

1. Treat the welding, ground, and control cables with respect. Avoid sharp bends and kinks which may break the cables. Don't use the cables as a "tow line" to move the control. Avoid damage or straining the cables where they enter the gun or at the connectors.

2. It is good practice to occasionally remove the cover of the controller and clean with air and a soft brush around the components.

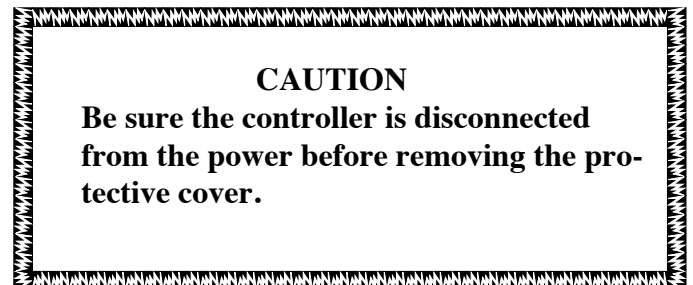

3. While the cover is removed, tighten all the weld cable connections and make sure all the screws on the capacitor terminals are torque to 30 inch-pounds.

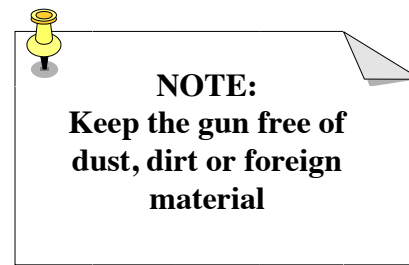

16.0 ASSEMBLY CD-212 CONTROLLER (see Figure 15,16, & 17)

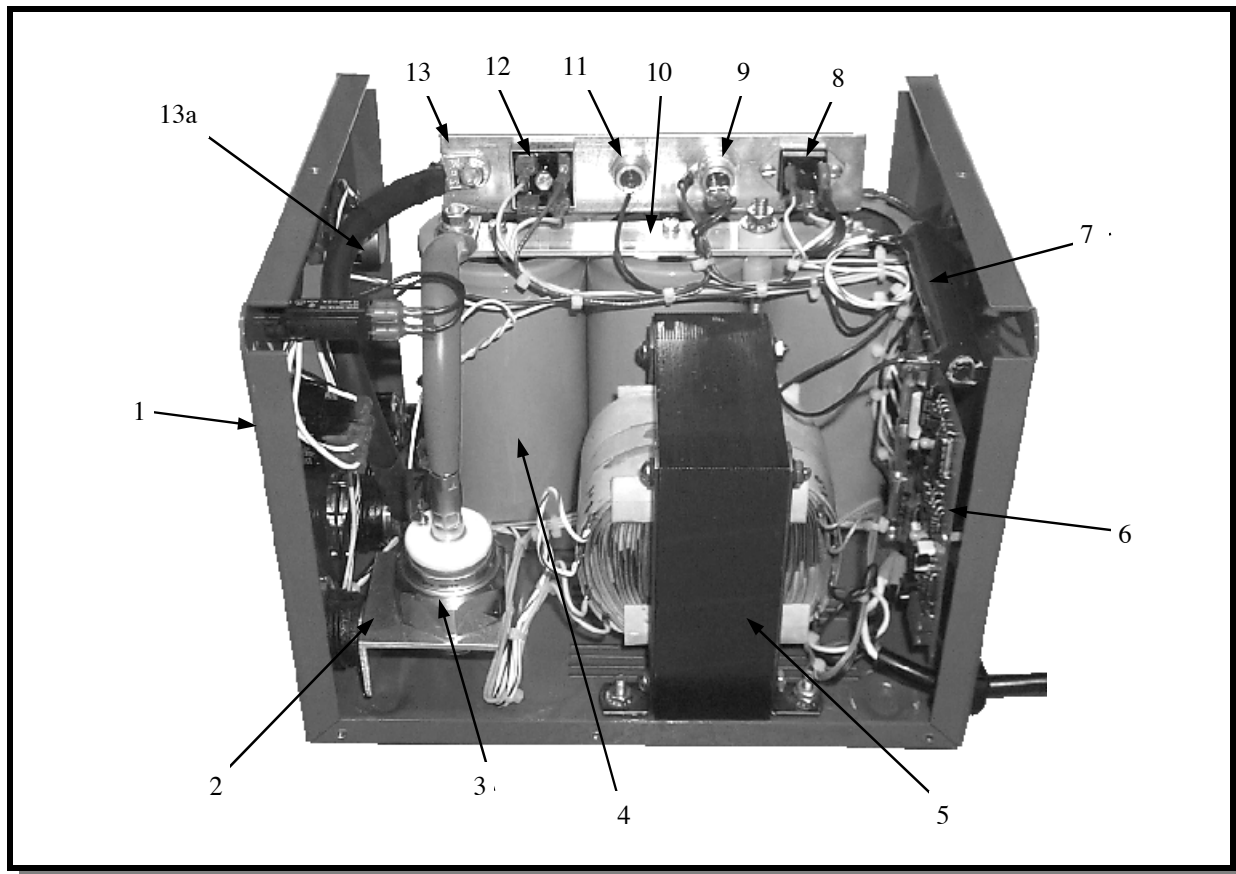

Figure 15 Parts List

ITEM	DESCRIPTION	PART NUMBER
1	Chassis	101-0025
2	SCR Mounting	124-0026
3	Main SCR	108-0001
4	Capacitor (3)	106-0023
5	Transformer	105-0017
6	PC Board	600-0013
7	Discharge Resistor	112-0041
8	Safety Discharge SCR	108-0042
9	Charging SCR	108-0002
10	Bus Bar	124-0034
11	Diode	108-0027
12	Charging Bridge	108-0017
13	Bus Bar	124-0035
13a	150K 2 Watt	111-0002

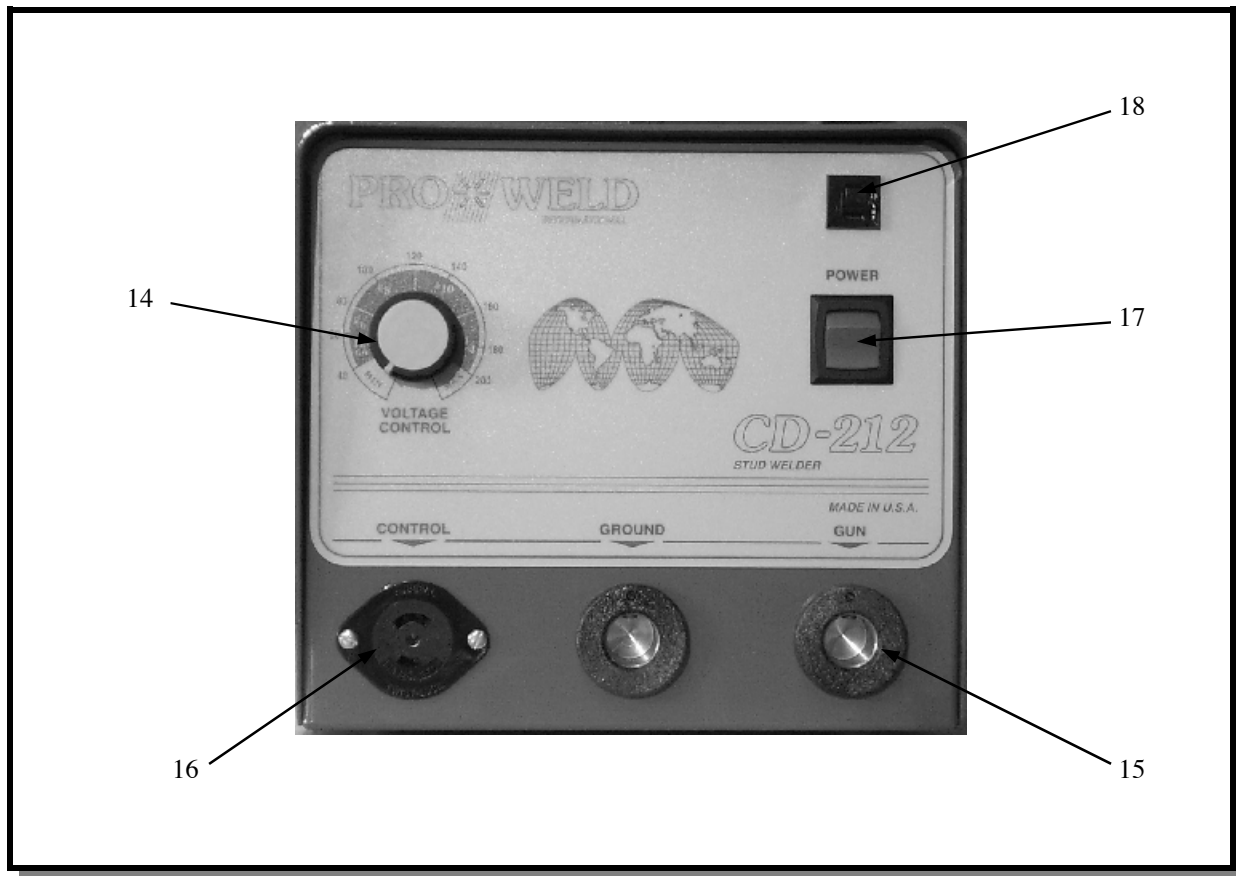

Figure 16 Parts List (continued)

ITEM	DESCRIPTION	PART NUMBER
14	Knob	102-0060
15	Female Camlok (2)	107-0002
16	2-Pole Female Hubbell	107-0031
17	Power Switch	104-0013
18	Circuit Breaker	104-0020

16.1 PC BOARD ASSEMBLY DRAWING
 FU1 and FU2 are 3AG 1 ampere fuses

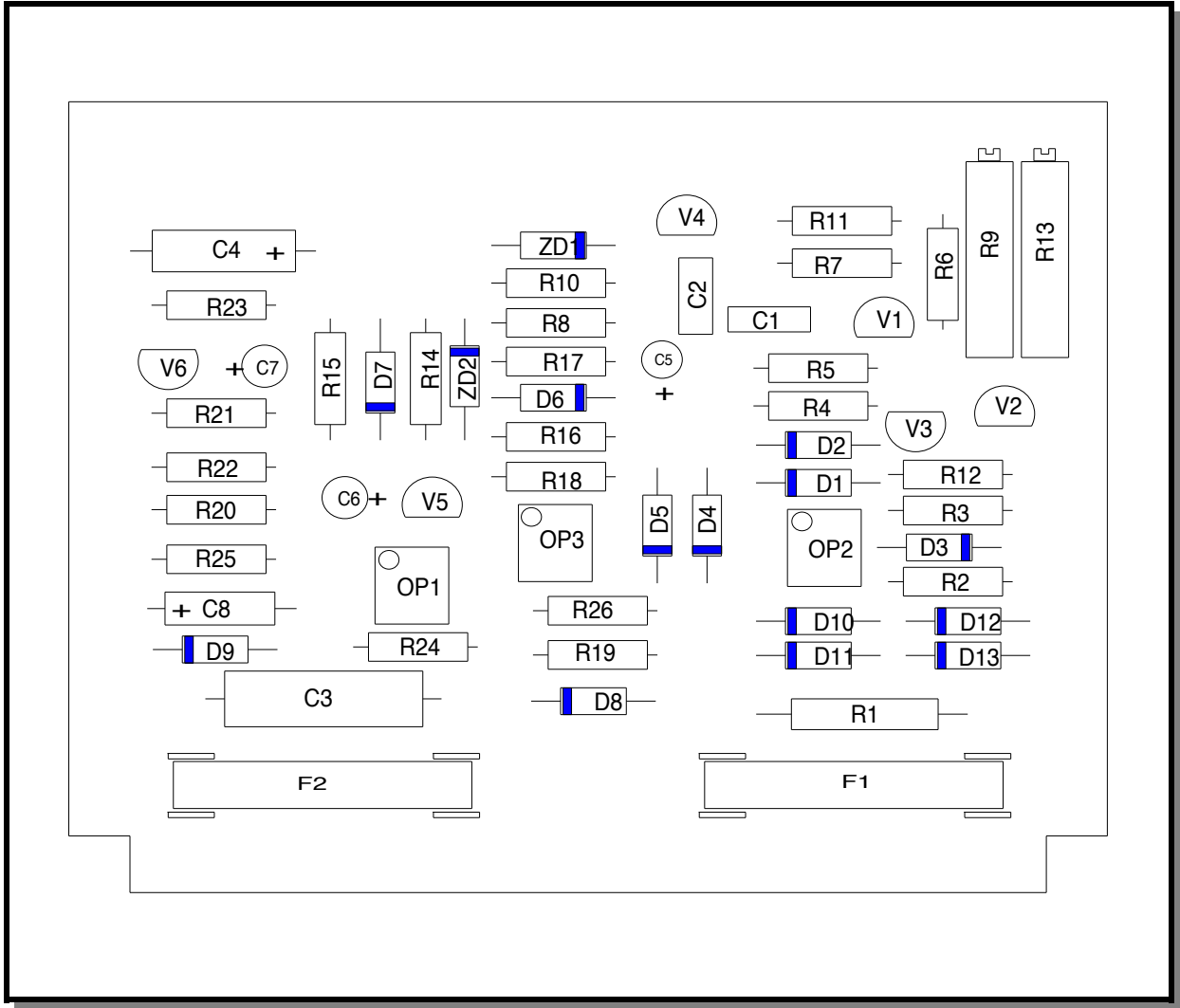

Figure 17 PC Board

17.0 TROUBLE SHOOTING – ELECTRICAL

When troubleshooting the power unit/controller (welder), the following precautions must be observed:

1. Welder must be **TURNED OFF!**
2. Unplug power cable from welder and wait at least two minutes before checking components.
3. The use of a volt/ohmmeter is recommended where any voltage may be present.
4. Use a continuity tester (or troubleshooting light) for continuity checks only.
5. Possible causes marked with a star (*) are generally the most common problems.

PROBLEM	POSSIBLE CAUSE	CORRECTIVE ACTION
1. Welder does not turn on and will not weld.	A. Power connections at Welder or 110 VAC outlet not complete.	Check connections.
	*B. Broken power cable or loose wire connection in the plug.	Check wires for continuity. Repair break.
	C. Fuse blown.	Replace fuse.
2. Fuse blows each time unit is turned on.	*A. Shorted weld capacitor.	Check safety vent seal for Rupture hole. Replace defective capacitor.
	B. Shorted rectifier (BR1)	Check for a short across the rectifier with ohmmeter. Replace rectifier module if shorted.
	C. Incorrect primary hookup.	Check transformer connections.
	D. Shorted transformer assembly.	Replace transformer.

PROBLEM	POSSIBLE CAUSE	CORRECTIVE ACTION
3. Welder turns on but does not operate	A. Ground cable connections not complete.	Check for continuity
	*B. Broken gun control cable or loose wire connection in the plug. Shorted or open trigger switch.	Check continuity between pins on control plug while trigger is depressed. Should read continuity.
	*C. Faulty printed circuit board.	Replace with new PC Board.
	D. Shorted weld SCR.	Check with ohmmeter (should not show continuity in either direction). Replace rectifier module if shorted.
4. Weld is excessively hot regardless of voltage setting.	A. Shorted charge SCR.	Check with ohmmeter (should not show continuity In either direction). Replace if shorted.
	*B. Faulty printed circuit board.	Replace with new PC Board.
	C. Open voltage potentiometer.	Replace defective voltage Potentiometer.
5. Poor and erratic welding.	A. Improper gun setup.	Check applicable gun setup Instruction page.
	B. Improper grounding or cable setup or incorrect polarity.	Check applicable cable setup Instruction page.
	C. Weld cables are coiled.	Straighten out cables.
	D. Incorrect voltage setting.	Adjust as necessary.
	E. Studs or pins not perpendicular to work surface.	Adjust legs as necessary. Replace defective legs.

18.0 CHECK LIST CD-212 SYSTEM PT. NO. 100-0112

STANDARD CD-212 WELDING SYSTEM COMPLETE WITH B-COLLET GUN
AND 25' #4 GROUND CABLE

ITEM	DESCRIPTION	PART #	QTY
1.	CD-212 CONTROLLER 110 VAC	200-0015	1
2.	GUN ASSY. B-COLLET w/INTEGRAL 25 FT.WELD & CONTROL CABLE 2-LEGS, and FOOTPIECE	300-0100	1
3.	GROUND CABLE #4 X 15'	125-0100	1
4.	MANUAL, Operation and Maintenance CD-212		1
5.	HEX WRENCH SET		1

19.0 CHECK LIST CD-212 SYSTEM PT. NO. 100-0113

STANDARD CD-212 WELDING SYSTEM COMPLETE WITH TAPER TIP GUN
AND 25' #4 GROUND CABLE

ITEM	DESCRIPTION	PART #	QTY
1.	CD-212 CONTROLLER 110 VAC	200-0015	1
2.	GUN ASSY. TAPER TIP w/INTEGRAL 25 FT.WELD & CONTROL CABLE 2-LEGS, and FOOTPIECE	300-0101	1
3.	GROUND CABLE #4 X 15'	125-0100	1
4.	MANUAL, Operation and Maintenance CD-212		1
5.	HEX WRENCH SET		1

MANUFACTURED BY
PRO  WELD
INTERNATIONAL

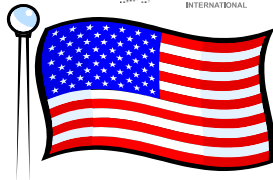

MADE IN THE U.S.A.