

N550c FACS
Flexible Arc Control System
Arc Charger 3/8" Drawn Arc Stud Welder

The N550c is Nelson's latest drawn arc stud welder enhanced by the FACS evolution to simplify stud welding everywhere

Dot Matrix Screen

The new FACS equipped N550c Arc Charger uses the familiar Dot Matrix interface the customers have used for years. The standard functions and display icons haven't changed so the operator can hit the ground running.

Portable

Weighing about 86 pounds, this machine is easy to move around. Included with each welder is the wheel kit that allows the user to roll the welder anywhere.

Short Cycle (SC) Capabilities

The short cycle features allow the user to weld automotive applications for W-Top, For Tree, and Ground studs.

Stud Expert

The new FACS-equipped N1500i includes the Stud Expert™ feature that helps the operator easily set-up a welding application. This wizard makes set-up as simple as determining the diameter and material to be welded.

Process Monitoring

The N550c welder includes quality monitoring features that allow the operators to evaluate each weld to ensure optimal repeatability.

Pulse Welding

The N550c welder allows the user to design custom waveforms to optimize the welding process. The pulses created by the user make welding Aluminum and other exotic materials possible by vaporizing oxides and contaminants on the base material surface.

Global Design

The new FACS-equipped N550c was designed to comply with world wide standards, and connect to any single phase household input power.

Plug & Play Motorized Gun Options

The new motorized gun driver module developed for the FACS system can simply replace the standard solenoid gun driver and connector.

Advanced Microprocessors & Communications

FACS uses cutting-edge microprocessor controls and will expand connectivity in the future for weld data.



N550c FACS

Flexible Arc Control System

Arc Charger 3/8" Drawn Arc Stud Welder

Welder Specifications		N550c		N550c SC	
Welding Process		Drawn Arc, Short Cycle, Gas Arc			
Welding Current (I)		100A—550A CA*		100A-1500A CA*	
Welding Time (T)		20ms—320ms CA*		20ms-50ms CA*	
Weight (welder only)		86lbs (39kg)			
Dimensions (L x W x H)		28" (72cm) x 11.4" (30cm) x 16.5" (42cm)			
Enclosure Rating		IP23S			
Guns		NS40 and PLM560			
Materials		Mild Steel, Stainless Steel, Aluminum, Alloys, and High Strength Steel			
Weld Rates	1/2" (13mm)	N/A	Studs/Min	14	Studs/Min
	3/8" (10mm)	8	Studs/Min	16	Studs/Min
	5/16" (8mm)	14	Studs/Min	18	Studs/Min
	1/4" (6mm)	28	Studs/Min	20	Studs/Min
Max Stud ϕ	Steel/SS	3/8" Pitch		14mm	
	Aluminum	3/8" Pitch		TBD	
Input Power		1 Phase 120V 60 Hz @ 16A			
		1 Phase 230V 50 Hz @ 8A			
Display		Dot Matrix			

* CA = Continuously Adjustable

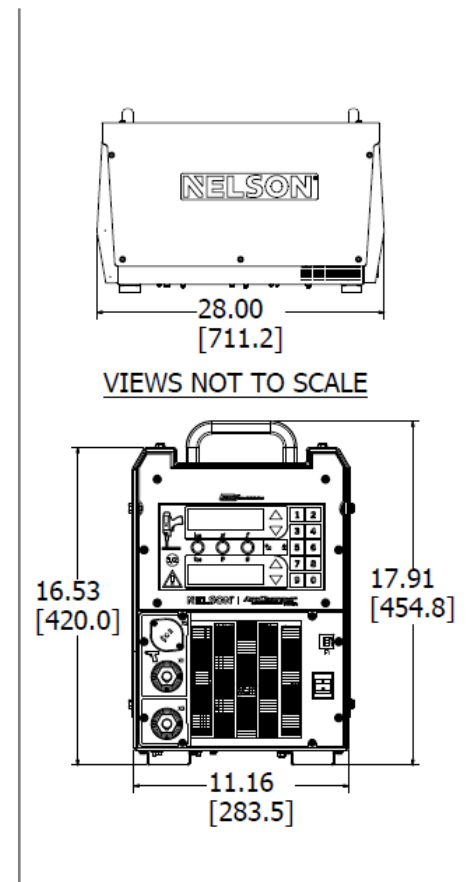

Stanley Engineered Fastening — a division of Stanley Black & Decker — is the global leader in precision fastening and assembly solutions. Our industry-leading brands elevate what our customers create. Backed by a team of passionate and responsive problem-solvers, we empower engineers to create the future.

STANLEY ENGINEERED FASTENING FAMILY OF BRANDS

AVDEL

INTEGRA

NELSON

OPTIA

POP

STANLEY
Assembly Technologies

TUCKER