

STANLEY[®]
Engineered Fastening



STANLEY[®]
Assembly Technologies

2020 Selection and Configuration Guide



TABLE OF CONTENTS

About STANLEY Fastening	4
How to Order Guide	8
Product Line	
EB-Series Corded Lever Style Tools	11
EB-Series Corded Fixtured Style Tools	31
Cable Options	52
B-Series Cordless Tools	57
Batteries	68
QBE Controllers	71
AA Series Pneumatic Tools	85
Specialty Tools	91
Sockets	92
DC Tool Accessories	118
Additional Resources	
Assembly Tool Definitions	129
Limited Warranty Statement	133
Certification and Compliance	134
Index	135

The Foundation of Tightening Excellence with STANLEY Assembly Technologies

STANLEY Assembly Technologies was founded in 1963 as a division of The **STANLEY Works**. Formerly STANLEY Air Tools, STANLEY Assembly Technologies has built a reputation as a leader in delivering high value assembly equipment solutions to customers in multiple industries across the globe.

Located in Cleveland, Ohio, the headquarters of STANLEY Assembly Technologies is proud to say that our precision threaded fastening products are *"Assembled in America with Global Components"*. Our Cleveland facility houses all functional business areas, including, but not limited to, operations, purchasing, customer service, engineering, quality, training, product management, marketing and service and support.

Extending global support and coverage, there are training and application centers in our Cleveland, Ohio facility, our STANLEY Engineered Fastening Automotive North American facility in Troy, Michigan as well as our STANLEY Engineered Fastening Automotive European Headquarters in Germany.

In support of our global customer base, STANLEY Engineered Fastening has sales and service office locations across the globe in France, Germany, Spain, China, India, Japan, Brazil and more.



Today, our highly skilled sales and service team works directly with major customers and supports a network of select distributor partners in all global areas. These veteran sales and service engineers are fully qualified to analyze end-user applications and propose the ideal selection of assembly tooling.

Our customers benefit from this experience in the following ways:

- » *Tool and application assistance by factory-trained, experienced sales and service engineers*
- » *Field service by technicians located strategically throughout the world*
- » *Design consultation for your specific application needs to identify or develop the design of the tool and the output to optimize performance and the life of the tool to your application*
- » *Engineered Systems has extensive expertise in the design and build of custom turnkey fastening solutions including automation, semi-automation, multiple spindle nutrunners and Bolt Holding tools, as well as Torque Tube and Articulating Arm systems*

STANLEY's Commitment to Quality:

- » **EXCEED**
Our Customer Expectations
- » **IMPROVE**
Our Company Continuously
- » **LEAD**
Our Industry

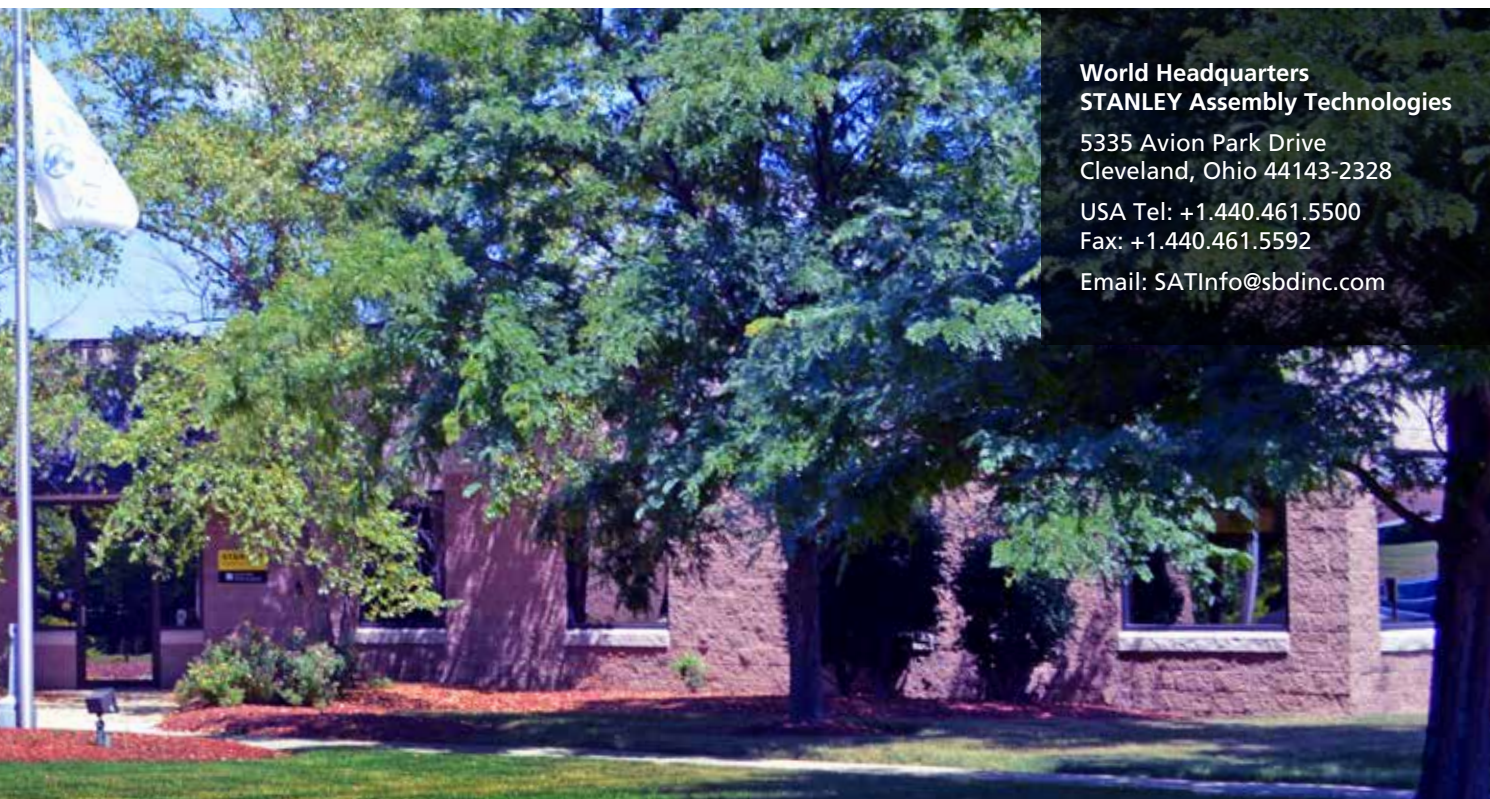

**World Headquarters
STANLEY Assembly Technologies**
5335 Avion Park Drive
Cleveland, Ohio 44143-2328
USA Tel: +1.440.461.5500
Fax: +1.440.461.5592
Email: SATInfo@sbdinc.com

About STANLEY Fastening



Ergonomic multi-finger triggers, handle size and high power-to-weight ratios make our tools user friendly and preferred by operators. Our tools are designed with the operator in mind.

ERGONOMIC BY DESIGN

As a major supplier of power tools to industrial manufacturing facilities worldwide, STANLEY Assembly Technologies has been involved in ergonomics since our inception in 1963. Ergonomic multi-finger triggers, handle size and high power-to-weight ratios make our tools user friendly and preferred by operators. Our tools are designed with the operator in mind.

From patented clutch designs in our air tools to patented speed control algorithms for DC Electric tools, we are continuously finding new ways to reduce the torque reaction impulse felt by the operator of our direct-drive tools.

We also offer a complete line of articulating arms and balance devices to provide alternative solutions to torque reaction strain on operators.

Our pistol style tools have been designed with an under slung handle which changes the center of balance and puts the tool weight directly over the hand. This allows the operator to hold the tool level without having to pull, then hold the tool, to the level position required with other handle-in-the-rear tool designs.

The safe use of our products is paramount to our company which has led to our working with national and international organizations to actively participate in the development of noise and vibration standards. Our tools have very low noise and vibration levels as a result of this participation.

While we must design tools for safe and convenient operation, the primary ergonomic concern is in the operator station design. The position of the operator, the position of the hand or arm, body attitude and reach while applying the tool are of critical importance. We can help mitigate ergonomic stresses by recommending the best tool geometry, reaction device and operator position to fit the application. You can rely on our expertise to recommend a safe working process while setting high integrity joints with ergonomically designed tools.

PREVENTIVE MAINTENANCE

To ensure years of trouble free operation we recommend establishing a program of inspection, maintenance and calibration of our power tools at regularly scheduled intervals.

Preventive maintenance, making repairs and replacing worn parts periodically before they become so worn and cause extensive damage can lower maintenance costs considerably and prevent loss of production.

REPAIR SERVICE

STANLEY Assembly Technologies strives to build tools that will remain on-the-job for years, using the highest grade material available. Mechanical and electrical components do wear out despite this high engineering effort. That is why we maintain a stock of repair parts for all of our power tools. We certify repair centers around the world annually to provide the best technical service and fast turnaround with genuine STANLEY parts. STANLEY Certified Repair Centers are capable of the same level of repair and test as our factory.

RECALIBRATING TOOLS

Instrumented power tools require periodic verification of their dynamic torque output by calibration of the torque sensing transducer. Our factory and our Certified Repair Centers maintain the capability to recalibrate any power tool using the latest electronic torque measuring equipment. A calibration certificate is supplied with each tool calibration performed.

TRAINING

STANLEY provides training at our Cleveland, Ohio and Troy, Michigan facilities. On-site customer training can also be arranged upon request. Topics include: Torque Theory, Tool Design and Operation, Controller Features and Benefits, Programming and Setup, Plant Integration, Networking, Data Collection and Troubleshooting of Faulted Joints. We encourage attendance in at least one of these training sessions to become more familiar with fastening in general and STANLEY's products specifically.

TECHNICAL SUPPORT

As a supplier to the assembly market, STANLEY has developed a global service network to support the manufacturing operations of our customers. STANLEY offers many levels of customer support from basic maintenance and operator training to full service repair facilities and maintenance service contracts.

PARTNERING

STANLEY Assembly Technologies has always believed that the relationship with our customers should be defined as a partnership. This partnership is based on:

- *Understanding customer fastening needs.*
- *Prompt and diligent resolution of issues.*
- *Our goal of being the first choice for your threaded fastening needs*

As a partner, we strive to provide improved fastening solutions that result in the ability to increase productivity while reducing warranty and total per unit fastening costs. STANLEY's superior solutions are designed to not only meet, but exceed customer expectations.

Tool and Controller Safety



EXPECT THE UNEXPECTED

- Secure what you are working on with a vise or clamps
- Avoid using excessive force unless in a controlled manner
- Tools requiring repair may act different than expected

TOOL SHOCK HAZARDS

- NEVER operate a tool with a defective cable
- Keep cables away from heat, solvents, and sharp edges
- NEVER carry a tool by the cable

DO NOT TAKE SHORTCUTS

- ALWAYS test for proper operation after tool and controller repair
- Understand the proper procedure for a repair prior to starting a repair

EXPECT TORQUE REACTION

- ALWAYS use a reaction device
- Never attempt to hold the torque reaction by hand

PROTECT YOURSELF

- Wear the appropriate PPE
- Keep spectators safely away from work area
- Do not wear gloves near rotating components
- ALWAYS Keep hands clear of moving parts

UNINTENTIONAL OPERATION

- ALWAYS disconnect the tool cable or battery when not in use
- ALWAYS remove power when working on the tools
- Keep fingers well away from the trigger while handling the tool

CONTROLLER SHOCK HAZARDS

- Allow the controller to de-energize prior to removing the safety panel
- ALWAYS disconnect all possible power sources
- Treat all electrical devices as if they are energized

TOOL SELECTION & CARE

- Use the right tool for the job
- Before using a power tool, ALWAYS check that it is in good working order
- Maintain according to manufacture's directions
- Always repair tools following the manufactures specifications

Catalog Guide & How to Order

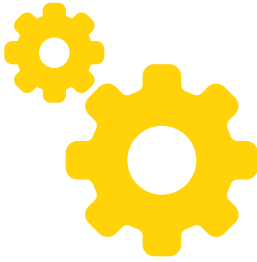

HOW TO ORDER

To configure a specific tool, check the options table that corresponds with the tool type, style and torque range listed. To receive the option requested installed and ready for service, add the option part number to the end of the tool model number — for example:

EB33LA18-48 with Rubber Grip and 360° Swivel Bail options installed and ready to use:

Qty:	Order Number:	Including:
1	EB33LA18-48	20H207910, 20K101400

To order options separately to be installed later, list the option item numbers as separate lines — for example:

EB33LA18-48 with Rubber Grip and 360° Swivel Bail options separate to be installed later:

Qty:	Order Number:
1	EB33LA18-48
1	20H207910
1	20K101400

Note: When ordering configurable options for a tool, the lead-time becomes that of the longest item added to the tool. Please contact a STANLEY Assembly Technologies sales professional for pricing, lead times and delivery.



TOOL SPEEDS

Tool speeds are indicated in revolutions per minute or “rpm” and indicates the free speed or the speed at which the tool runs at no load. Pneumatic tool speeds are rated at a working pressure of 6.3 bar, or 90 psi if not stated otherwise and can deviate up to +/- 10% from the stated value. Electric tool speeds are the rated (maximum) speed of the tool. Variable speeds lower than rated are available through the programming interface.



TOOL WEIGHTS

Tool weights are published in both Kilograms (kg) and Pounds (lb). All tool weights are approximate and some slight variations from engineering changes are possible.

Tool Labeling Key

All of the STANLEY Assembly Technologies' tools use a common lettering/numbering structure that will guide the user through the process of choosing the correct tool in the correct form for use. There are three separate lines of tools presented in the catalog and a clear method of naming and understanding has been implemented for ease of use.

The tool key below explains the significance of the letters/numbers forming the name of the tool model and part number.

DC Electric Tools

E B 3 3 L A 18 46

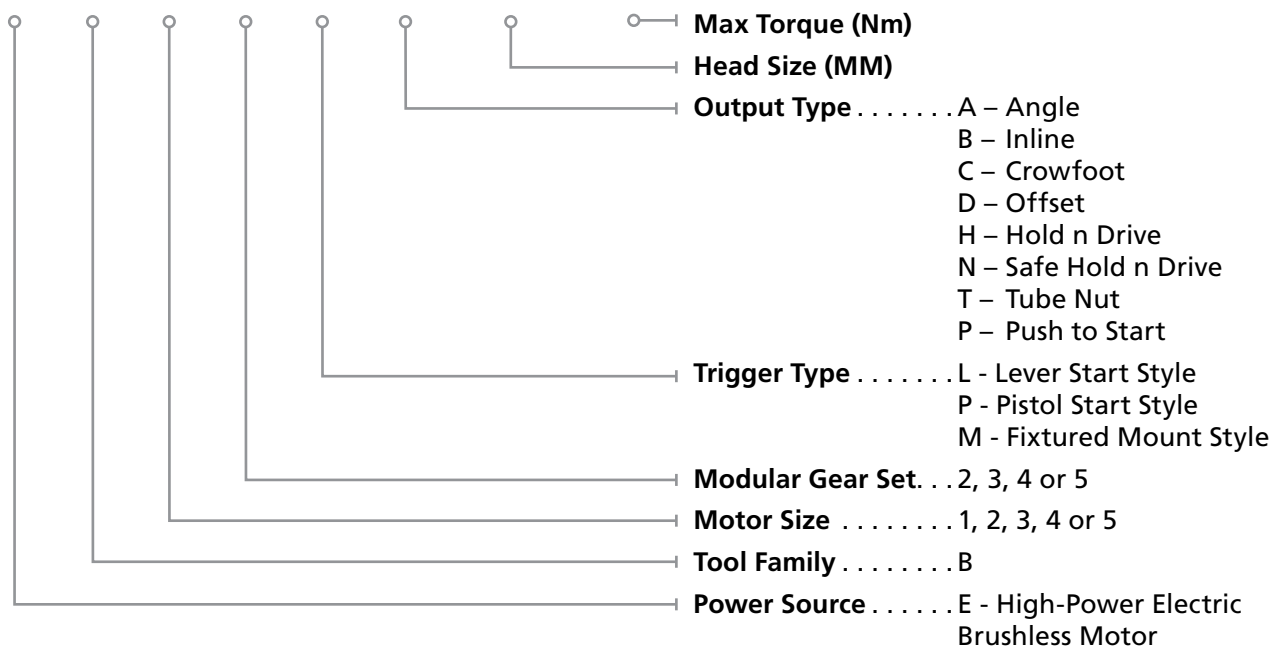

Air Clutch Tools

A A 3 3 L A 18 46

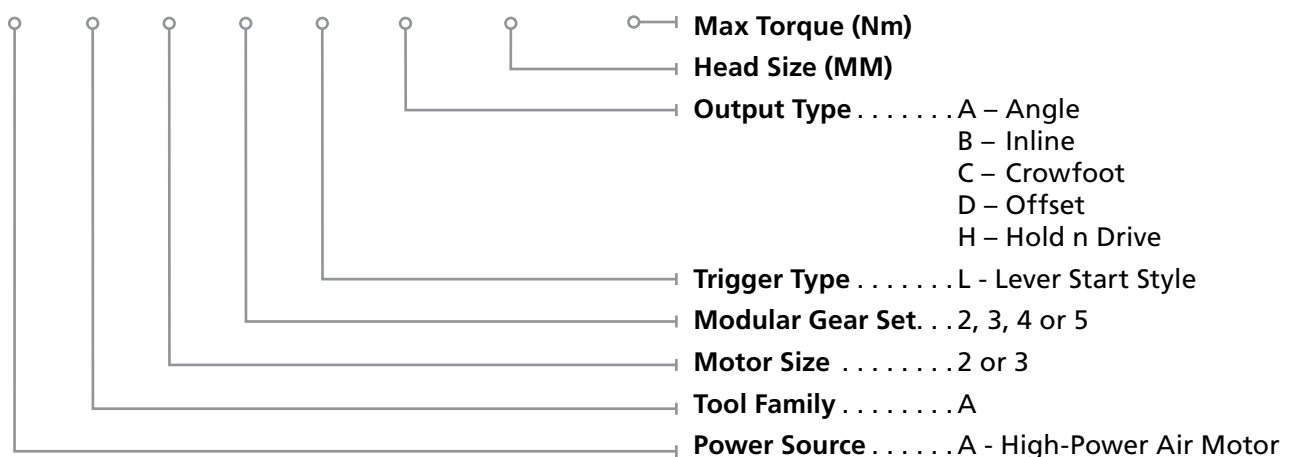

EB-Series: Reliability and Performance

The STANLEY Assembly Technologies EB-Series tools have been engineered to combine the latest technologies with STANLEY's best design features resulting in best-in-class tools.

FEATURES AND BENEFITS:

- **Low Friction Gearing** — In both gearbox and angle head assemblies for reduced noise and vibration for improved ergonomics.
- **High Efficiency Motor** — For best-in-class Power-to-Weight ratio.
- **Modular Construction** — For low MTTR (*Mean Time To Repair*). Common components reduce complexity and cost:
 - » *Handle/Lever assembly common to all handheld tools.*
 - » *Motor sizes*
 - » *Modular gear sets*
 - » *Angle heads*
- **Field Repairable** —
 - » *Matched replacement gear sets*
 - » *Grease fittings on all angle tubenut and crowfoot outputs for ease of preventive maintenance*
- **Full Line of Tools** — *0.4 Nm to 2000 Nm with geometries to fit a wide range of applications*



EB-Series: Lever Style

THE STANLEY ADVANTAGE:

**Industry Leading
Power-to-Weight Ratio**

NEW! High Speed Motor
Smoother and Lighter

NEW! High Speed Gearing
*Quieter and
Cooler Running*

**Durable
Motor Cover**

**NEW! Grease
Fitting Location**



- *High/OK/Low Lights indicate fastening status with 360° viewing.*
- *Multifunction button can select from 2 job setups and other process functions.*

A non-contact optical switch under the start lever increases Mean Time Between Failure (MTBF) by eliminating mechanical or magnetic switches which wear out over time.

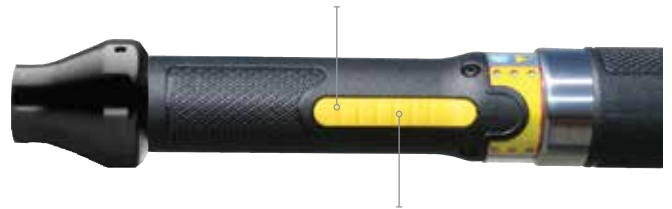

Increased lever length, recessed mounting, and "flush to handle" activation improves fit to the operator's hand.

**Optional accessories include
Forward Facing Levers.**



Clear cover protects multifunction panel and model number label.



Recessed multifunction button requires minimal pressure with tactile feedback. A raised ring prevents accidental activation.

EB-Series: Pistol Style

Faster Models to 470 Nm

Intelligently Positioned Status Lights

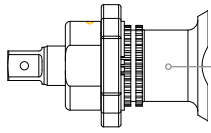

Optional 1/4" or 3/8" Square Drive Outputs.

Push-To-Start

Optional



Brilliant Headlights
Illuminate Low Light
Fastener Access Points

Programmable Buttons
Improve Operator
Effectiveness

Ergonomic
Handle Design for
Operator Comfort

Use Lite Cables for
Better Ergonomics

Fast Tools for Small Jobs

Lighter, Faster, More Power

- Torque Ranges up to 20 Nm
- All Models Under:
 - » 2 lbs (0.9 Kg) in weight
 - » 1 foot (305 mm) in length
- Push-To-Start Models Include Headlights
- Available with Crowfoot and Tubenut Outputs

Push-To-Start

Optional

EB-Series Torque Range: Pistol & Lever Style

The EB-Series Corded Tool Product Line offers hand-held and fixtured tools up to 2000 Nm.

Inline Pistol Grip

MODELS:

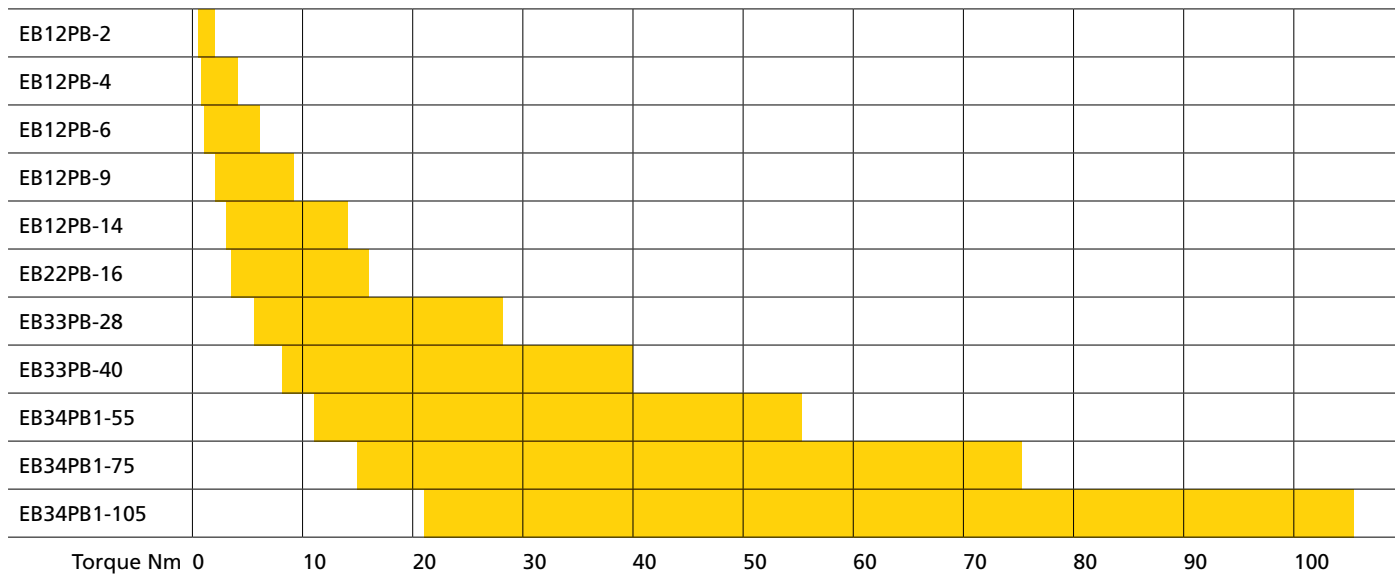

Push-to-Start Pistol Grip

MODELS:

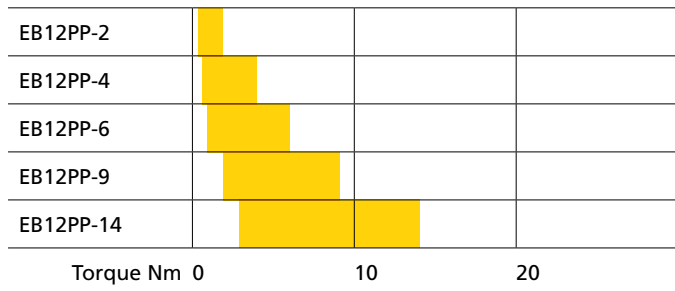

Push-to-Start Lever Style

MODELS:

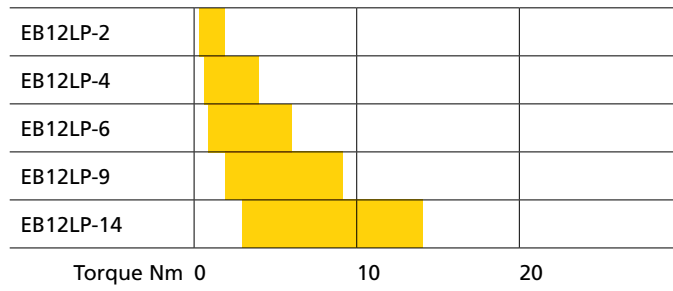

Please Note: These charts are a guide for the use of our tools. Programming of these tools can have a direct effect on the capability and performance.

Inline Lever Style

MODELS:

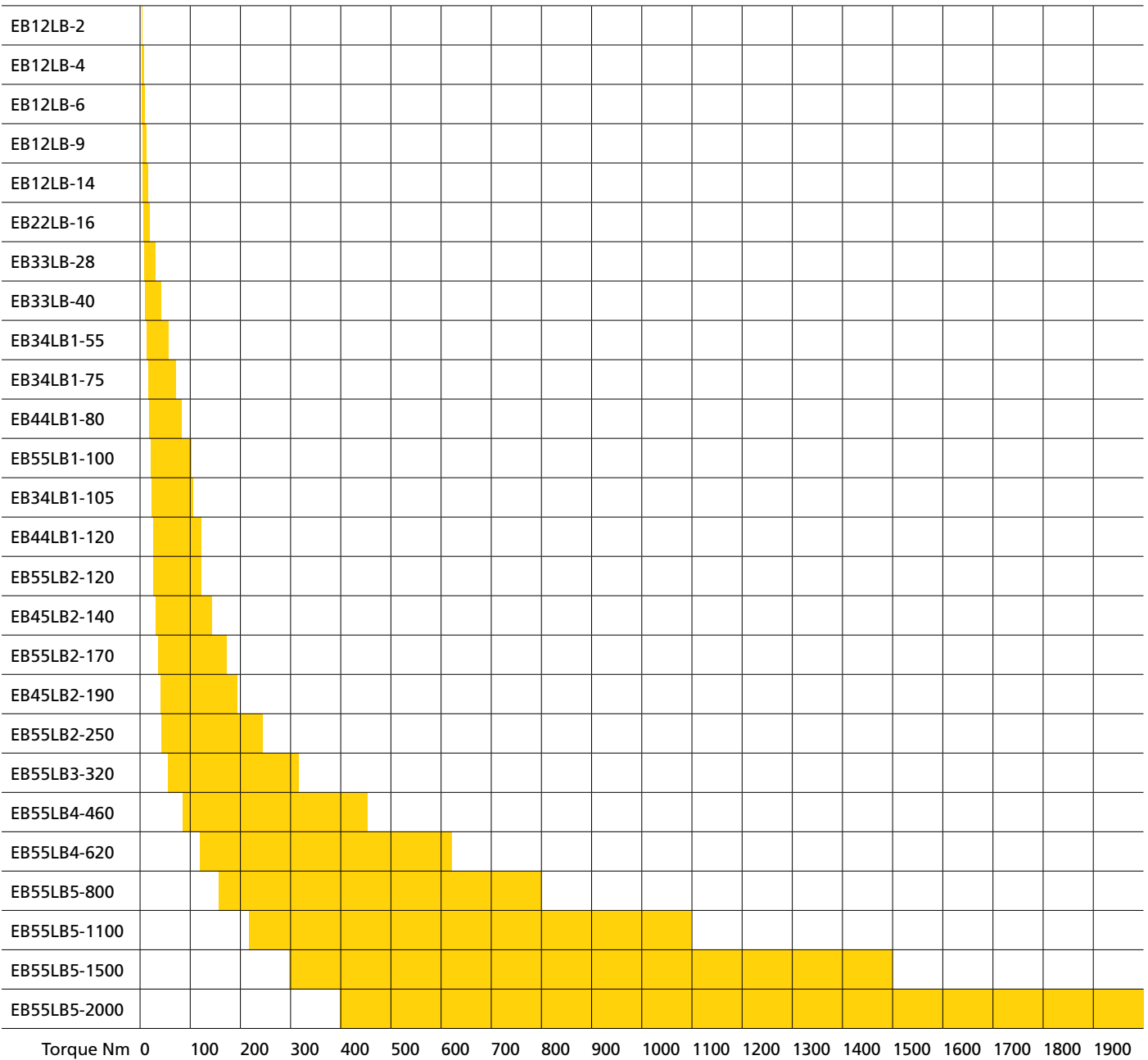

Please Note: This chart is a guide for the use of our tools. Programming of these tools can have a direct effect on the capability and performance.

Angle Lever Style

MODELS:

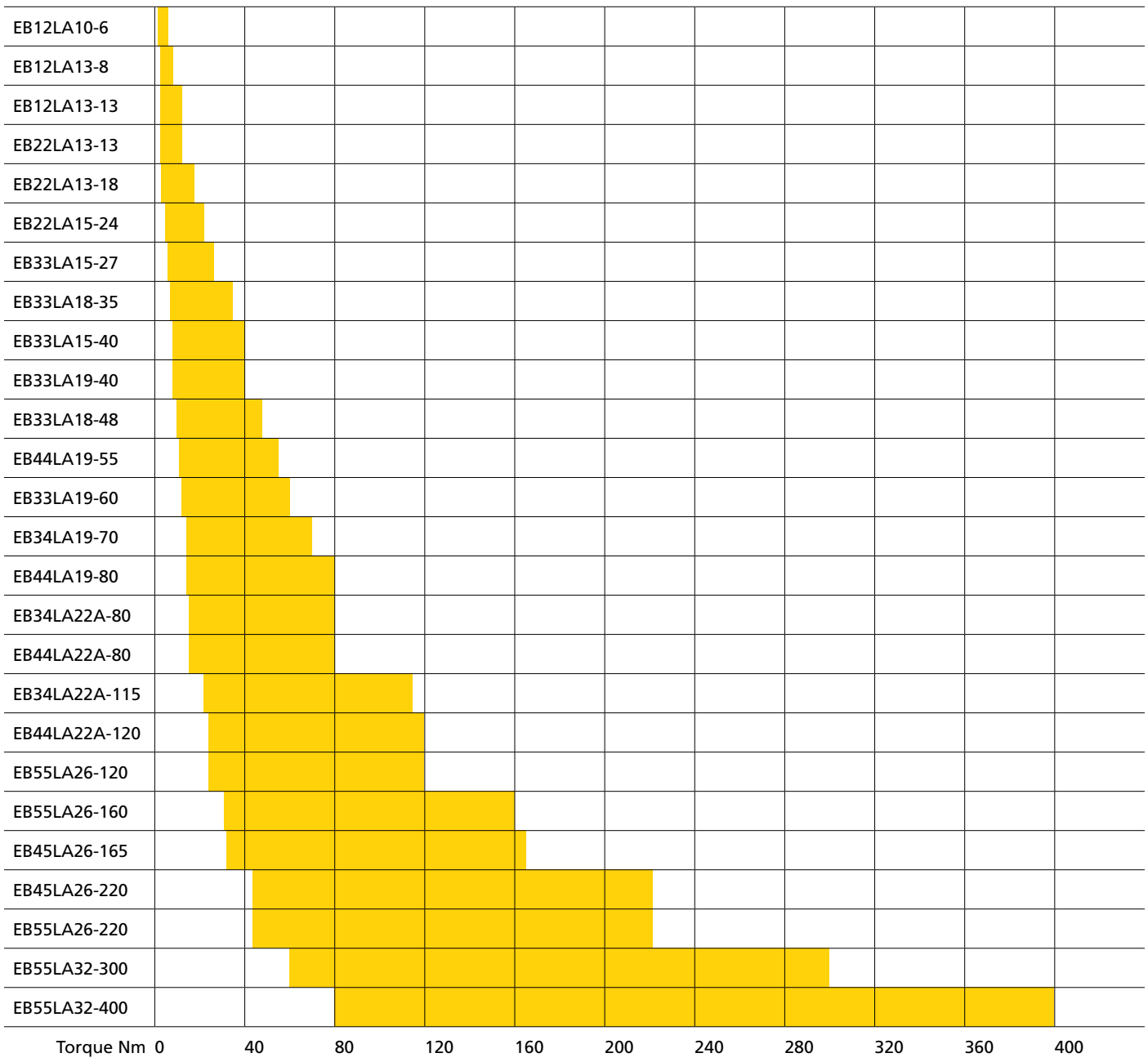

Please Note: This chart is a guide for the use of our tools. Programming of these tools can have a direct effect on the capability and performance.

Hold and Drive Lever Style

MODELS:

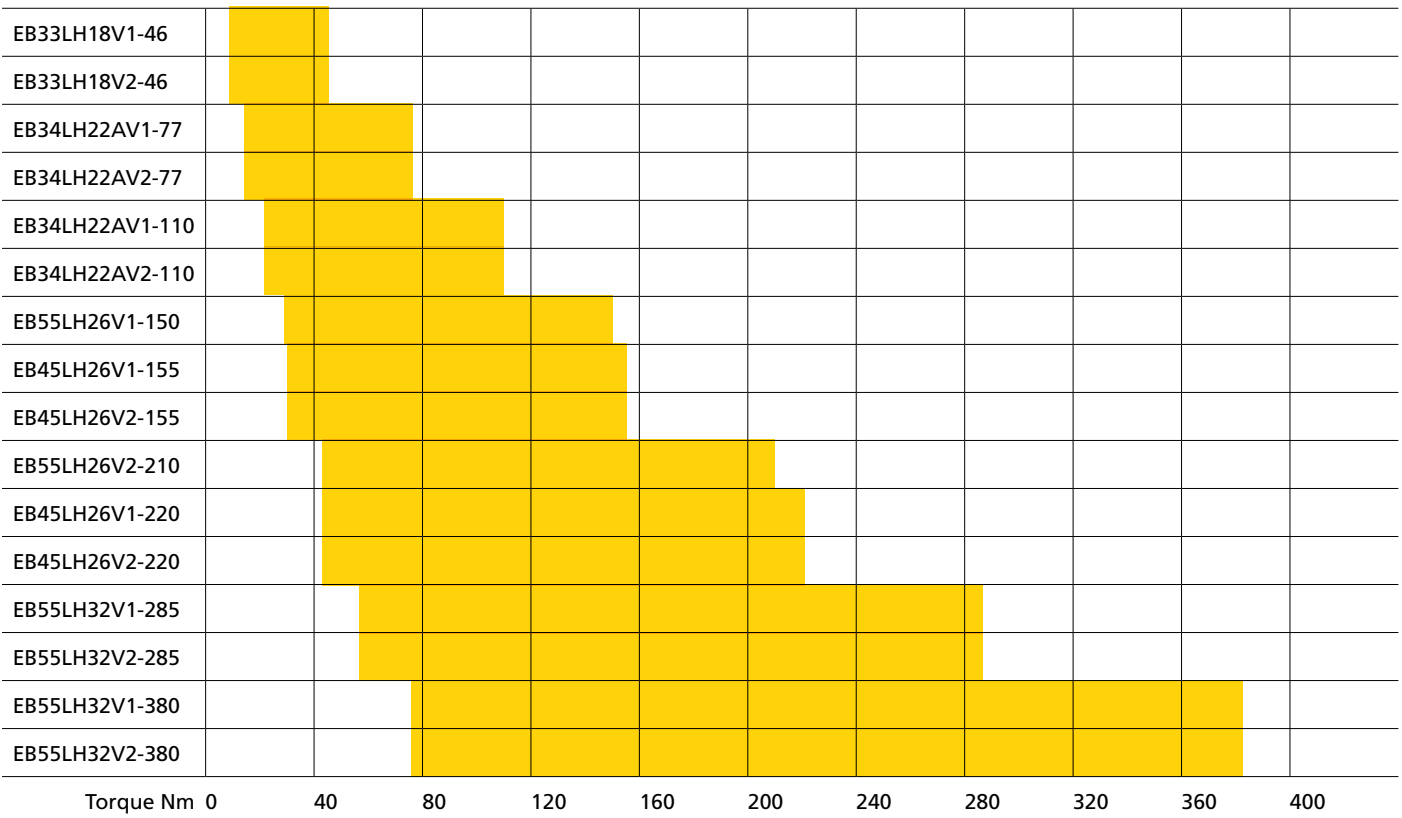

Tubenut Lever Style

MODELS:

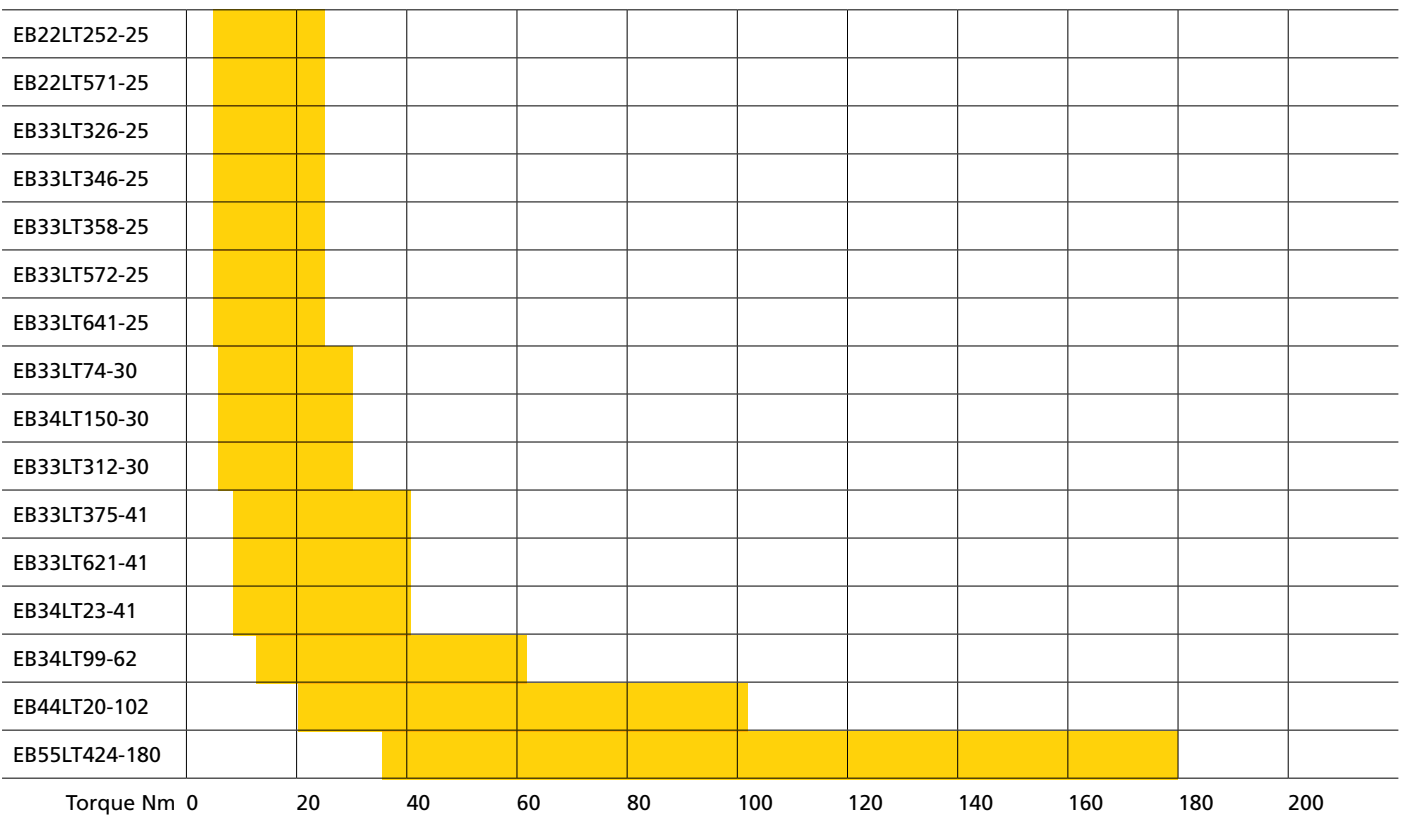

Please Note: These charts are a guide for the use of our tools. Programming of these tools can have a direct effect on the capability and performance.

Crowfoot Lever Style

MODELS:

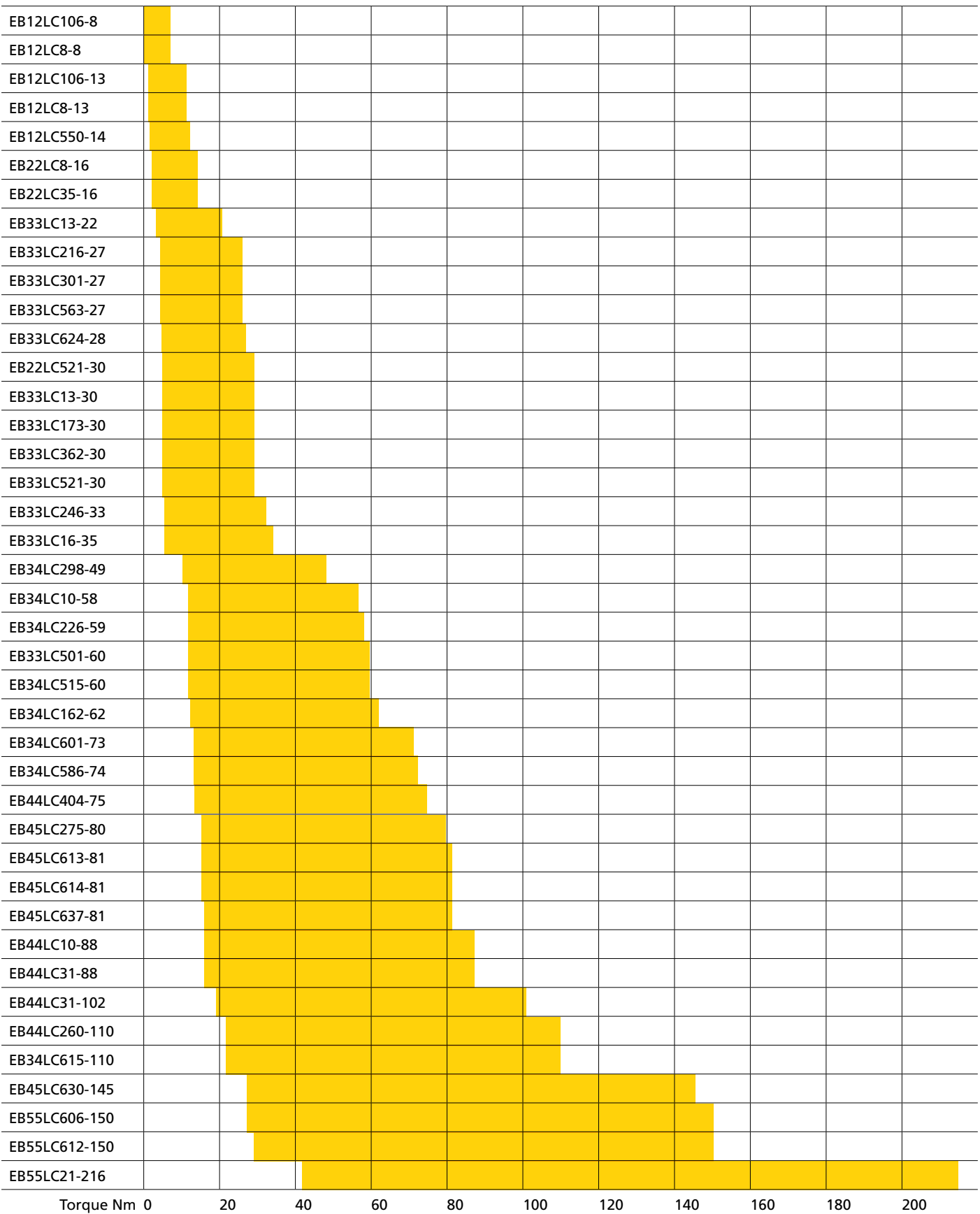

Please Note: This chart is a guide for the use of our tools. Programming of these tools can have a direct effect on the capability and performance.

Angle Lever Tools

1.2 to 60 Nm

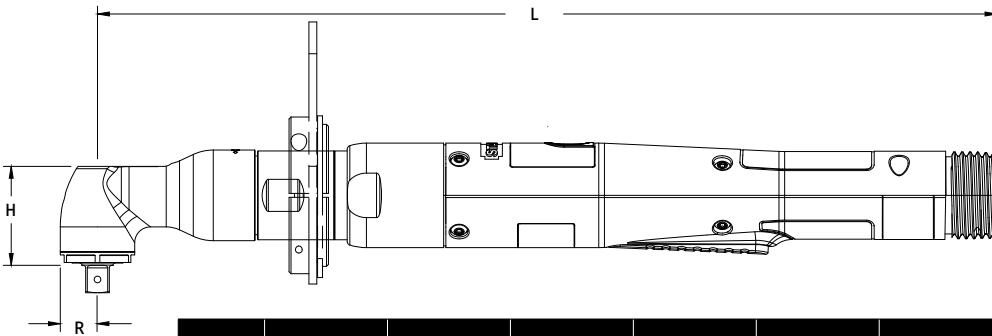

Model	Rated Speed		Max Torque		"R" Side to Center		"H" Head Height		"L" Length		Weight		Output
	RPM	Nm	lb ft	mm	in	mm	in	mm	in	kg	lb	Standard	
EB12LA10-6	2110	6	4.42	10	0.39	31.9	1.26	319.3	12.6	0.89	1.96	1/4" SD	
EB12LA13-8	1400	8	5.90	13	0.51	32.7	1.29	321.6	12.7	0.93	2.05	3/8" SD	
EB12LA13-13	970	13	9.58	13	0.51	32.7	1.29	321.6	12.7	0.93	2.05	3/8" SD	
EB22LA13-13	1550	13	9.58	13	0.51	32.7	1.29	343.3	13.5	1.08	2.38	3/8" SD	
EB22LA13-18	1075	18	13.3	13	0.51	32.7	1.29	343.3	13.5	1.08	2.38	3/8" SD	

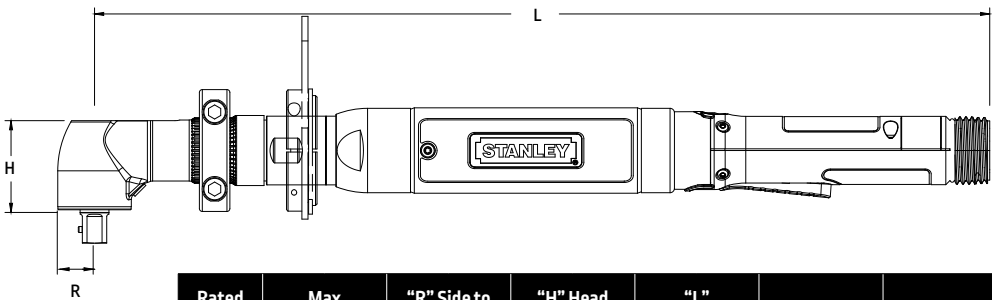

Model	Rated Speed		Max Torque		"R" Side to Center		"H" Head Height		"L" Length		Weight		Output
	RPM	Nm	lb ft	mm	in	mm	in	mm	in	kg	lb	Standard	
EB22LA15-24	825	24	17.7	15	0.59	36.5	1.44	366.5	14.4	1.21	2.66	3/8" SD	
EB33LA15-27	1515	27	19.91	15	0.59	36.5	1.44	415.7	16.4	1.55	3.41	3/8" SD	
EB33LA18-35	1165	35	25.81	18	0.71	39.3	1.55	444.7	17.5	1.66	3.65	3/8" SD	
EB33LA15-40	1015	40	29.49	15	0.59	36.5	1.44	415.7	16.4	1.55	3.41	3/8" SD	
EB33LA19-40	1025	40	29.49	19	0.75	48.7	1.92	458.4	18.0	1.87	4.11	1/2" SD	
EB33LA18-48	880	48	35.39	18	0.71	39.3	1.55	455.4	17.9	1.66	3.65	3/8" SD	
EB33LA19-60	680	60	44.24	19	0.75	48.7	1.92	458.4	18.0	2.04	4.50	1/2" SD	

EB Angle Tool Output Options

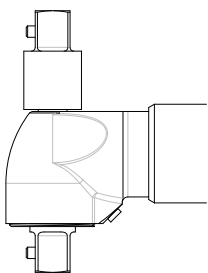

Double Ended

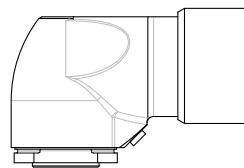

Flush

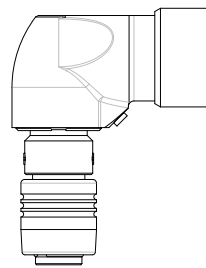

Quick Change

EB Angle Tool Options

A10 Output	Part No.
3/8" Square Drive	20D122901
1/4" Quick Change	20D122902
A13 Output	Part No.
3/8" Double-Ended, LH Thread*	20D121912
Flush Socket 10mm Max	20D121914
1/4" Quick Change	20D121916
3/8" Double-Ended, RH Thread*	20D121917
Flush Socket 13mm Max	20D121918
1/4" Square Drive	20D121919
1/4" Magnetic Internal Hex	20D121920
A15 Threaded Output 20D137500	Part No.
3/8" Square Drive	20D138900
Flush Socket	20D138904
1/2" Square Drive	20D138901
A15 Output Splined 20D137504	Part No.
3/8" Square Drive	20D138900
Flush Socket	20D138902
1/2" Square Drive	20D138901
A18 Output	Part No.
3/8" Square Drive	20D136500
3/8" Double-Ended, RH Thread*	20D136502
Flush Socket	20D136503
A19 Threaded Output	Part No.
Flush Socket	20D100021
Reaction Bar (A15 Splined/ A19)	Part No.
Reaction Bar Assembly (Default)	20K100000
Mounting Flange Assembly	20K100300
Base Mount Bracket Assembly	20K100500
*RH-Thread is Right-Hand Thread. This is an option used if the end user uses the additional output for clockwise tightening or loosening. LH-Thread is Left-Hand Thread. This is an option used if the end user uses the additional output for counter-clockwise tightening or loosening.	
Suspension Balls	Part No.
Wire Bail (EB_2/3/4 Tools)	A3061
Swivel (A10, EB12LA13 only)	20K101402
Swivel (EB22LA13, A15, A18 only)	20K101400
Swivel (A19, A22 only)	20K200000
Standard (A13, A15, A18 only)	B3432
Vinyl Covers	Part No.
A10 Output	20D250711
A13 Output	20D250711
A15 Output	20D250701
A18 Output	20D250702
A19 Output	20D250707
Socket Lock Pin 3/8" or 1/2" SD	Part No.
Standard	20D227800
Rounded (Ball Detent)	20D227801
Handle Options	Part No.
EB22 Forward Facing Lever	20H100108
EB3/4/5 Forward Facing Lever	20H100107

Angle Lever Tools

11 to 400 Nm

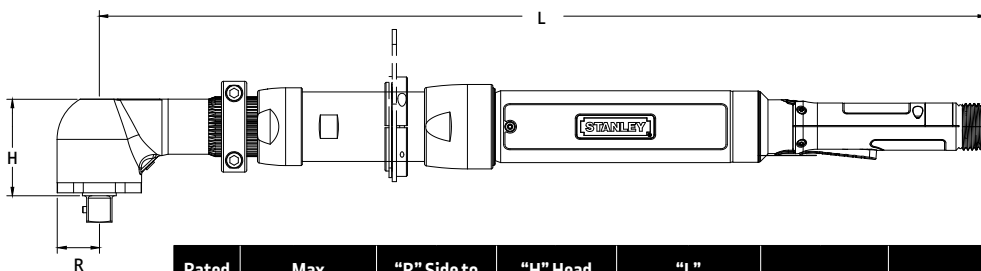

Model	Rated Speed		Max Torque		"R" Side to Center		"H" Head Height		"L" Length		Weight		Output
	RPM	Nm	lbft	mm	in	mm	in	mm	in	kg	lb	Standard	
EB44LA19-55	1190	55	40.55	19	0.75	48.7	1.92	458.4	18.0	2.78	6.12	1/2" SD	
EB34LA19-70	610	70	51.61	19	0.75	48.7	1.92	488.0	19.2	2.34	5.15	1/2" SD	
EB44LA19-80	845	80	58.98	19	0.75	48.7	1.92	525.4	20.7	2.78	6.12	1/2" SD	
EB34LA22A-80	510	80	58.98	22	0.87	50.0	2.0	530.0	20.9	2.66	5.85	1/2" SD	
EB44LA22A-80	810	80	58.98	22	0.87	50.0	2.0	539	21.2	3.10	6.82	1/2" SD	
EB34LA22A-115	340	115	84.79	22	0.87	50.0	2.0	530.0	20.9	2.66	5.85	1/2" SD	
EB44LA22A-120	550	120	88.48	22	0.87	50.0	2.0	539	21.2	3.29	7.23	1/2" SD	
EB55LA26-120	825	120	88.48	26	1.02	60	2.4	632	24.9	5.72	12.58	3/4" SD	
EB55LA26-160	620	160	117.97	26	1.02	60	2.4	632	24.9	5.81	12.78	3/4" SD	
EB45LA26-165	400	165	121.65	26	1.02	60	2.4	582	22.9	5.25	11.56	3/4" SD	
EB45LA26-220	260	220	162.21	26	1.02	60	2.4	582	22.9	5.57	12.27	3/4" SD	
EB55LA26-220	460	220	162.21	26	1.02	60	2.4	632	24.9	5.83	12.82	3/4" SD	
EB55LA32-300	340	300	221.19	32	1.26	73	2.9	639	25.1	6.46	14.21	3/4" SD	
EB55LA32-400	225	400	294.92	32	1.26	73	2.9	639	25.1	6.46	14.21	3/4" SD	

Inserts for 20D102204 A32 Hex Insert Output

Description	Part No.
1-1/8" Hex Socket Insert	A5172
30mm Hex Flush Socket Insert	20D222100
30mm with 3/4" Extension Flush Socket Insert	20D228900

The maximum hex size for the A32 Flush Socket Output is 27 mm (1-1/16").

Use the Hex Insert Output with these Inserts for larger hex sizes.

This will add 16.3 mm (0.64") to the "H" dimension of the tool.

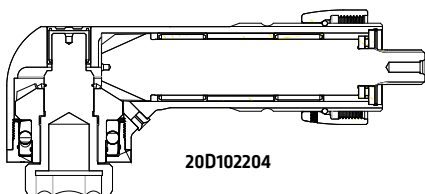

Mounting / Reaction Options

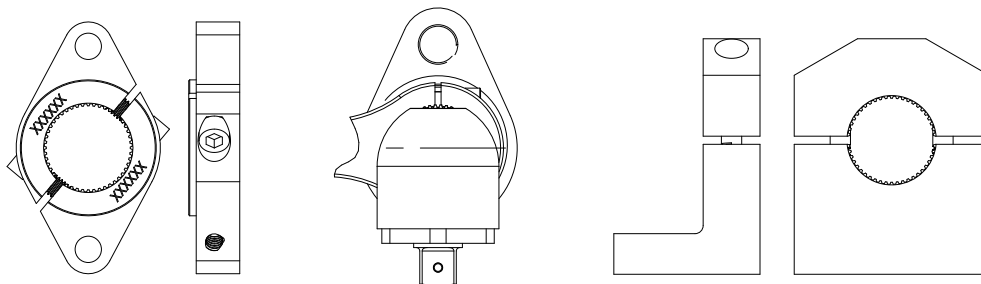

Optional Flange Mount Bracket

Reaction Bar or Bail

Optional Base Mount Bracket

EB Angle Tool Options

A19 Splined Output	Part No.
Anti-Vibration 1/2" SD	20D100101
Flush Socket	20D100106
1/2" Double-Ended, RH Thread*	20D100107
A22A Output	Part No.
1/2" Square Drive	20D100305
Flush Socket	20D100309
1/2" Double-Ended, RH Thread*	20D100326
Reaction Bar (A19 & A22 Outputs)	Part No.
Reaction Bar Assembly	20K100000
Mounting Flange EB34, EB44	20K100400
Base Mount Bracket Assembly	20K100500
A26 Output	Part No.
3/4" Square Drive	20D1004010
Flush Socket	20D100409
A32 Output	Part No.
3/4" Square Drive (Pin)	20D102200
3/4" Square Drive (Ball)	20D104300
Flush Socket	20D102201
Hex Insert	20D102204
Reaction Bar (A26 & A32 Outputs)	Part No.
Reaction Bar, Steel (<300 Nm)	20K100200
Reaction Bar, Steel (>300 Nm)	20K100202
Base Mount Bracket	20K100600
Mounting Flange-B	20K100700

*RH-Thread is Right-Hand Thread. This is an option used if the end user uses the additional output for clockwise tightening or loosening.

Suspension Balls	Part No.
Swivel (A19, A22A only)	20K200000
Swivel (A26, A32 only)	20K200100
Vinyl Covers	Part No.
A19 Output	20D250707
A22 Output	20D250708
A26 Output	20D250709
A32 Output	20D250710
Socket Lock Pin 3/8" or 1/2" SD	Part No.
Standard	20D227800
Rounded (Ball Detent)	20D227801
Socket Lock Pin Lock Pin 3/4" SD	Part No.
Standard	20D227800
Rounded (Ball Detent)	20D227802
Handle Options	Part No.
EB3/4/5 Forward Facing Lever	20H100107



Sockets and Accessories begin on page 92

Inline Pistol Grip Tools

0.4 to 105 Nm

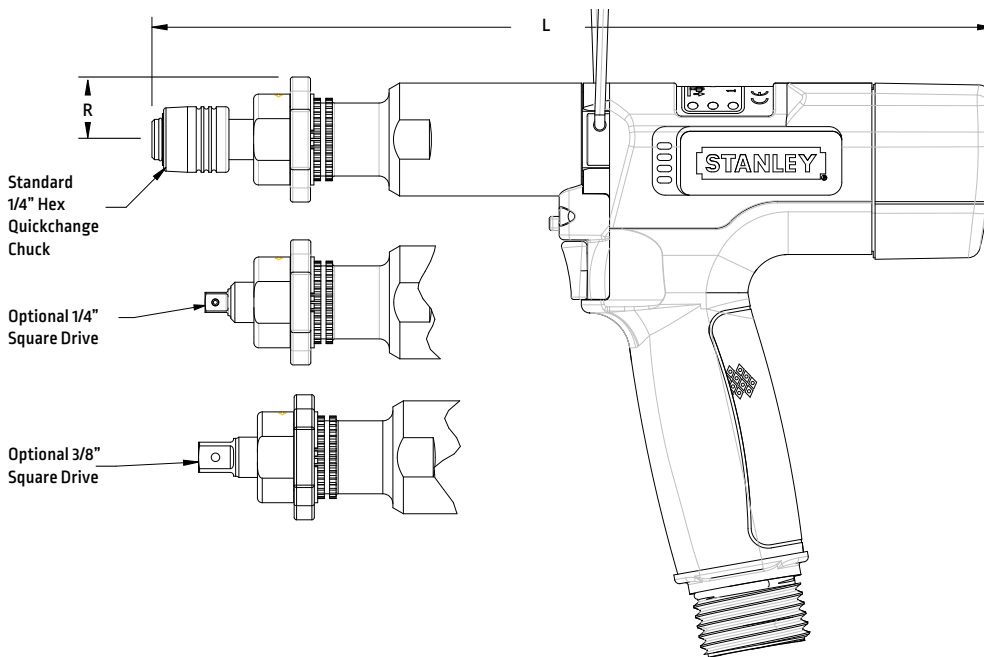

EB Pistol Tool Options

Output Options	Part No.
3/8" SD	20D119301
1/4" SD	20D119302
Socket Lock Pin 3/8" or 1/2" SD	Part No.
Standard	20D227800
Rounded (Ball Detent)	20D227801
Reaction Bar	Part No.
Spacer (Default)	20D217000
Reaction Bar, Aluminum, 17"	20K100103
Reaction Bar, Steel, 17"	20K100104
Suspension Bail	Part No.
Wire Bail	A3061
Handle Grip	Part No.
Rubber Grip	20H207107

Cable Exit	Part No.
Top Exit EB1	20H106302
Top Exit EB3	20H209613

Model	Rated Speed		Max Torque		"R" Side to Center		"L" Length		Weight		Output
	RPM		Nm	lb ft	mm	in	mm	in	kg	lb	Standard
EB12PB-2	1760		2	1.5	20	0.8	222	8.7	0.78	1.7	1/4 QC
EB12PB-4	1115		4	2.9	20	0.8	222	8.7	0.78	1.7	1/4 QC
EB12PB-6	2300		6	4.4	20	0.8	264	10.4	0.78	1.7	1/4 QC
EB12PB-9	1595		9	6.6	20	0.8	264	10.4	0.78	1.7	1/4 QC
EB12PB-14	1020		14	10	20	0.8	264	10.4	0.78	1.7	1/4 QC
EB22PB-16	1225		16	11	20	0.8	290	11.4	1.16	2.5	1/4 QC
EB22PB-20	981		20	14.8	20	0.8	290	11.4	1.21	2.7	1/4 QC

Optional Top Exit

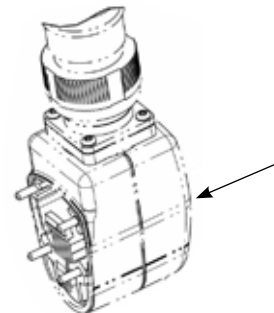

Requires EB Fitted Whip Cable 20C1093XX

Model	Rated Speed		Max Torque		"R" Side to Center		"L" Length		Weight		Output
	RPM		Nm	lb ft	mm	in	mm	in	kg	lb	Standard
EB33PB-28	1590		28	20	26	1.04	288	11.3	1.49	3.2	3/8" SD
EB33PB-40	1120		40	29	26	1.04	288	11.3	1.55	3.4	3/8" SD
EB34PB1-55	830		55	40	32	1.25	324	12.8	2.31	5.10	1/2" SD
EB34PB1-75	545		75	55.3	32	1.25	324	12.8	2.55	5.6	1/2" SD
EB34PB1-105	410		105	77.5	32	1.25	324	12.8	2.55	5.6	1/2" SD

Optional Rubber Grip

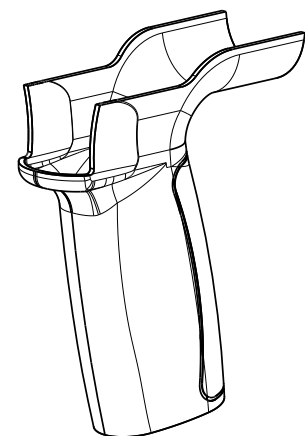

Inline Push-to-Start Pistol Grip Tools

0.4 to 14 Nm

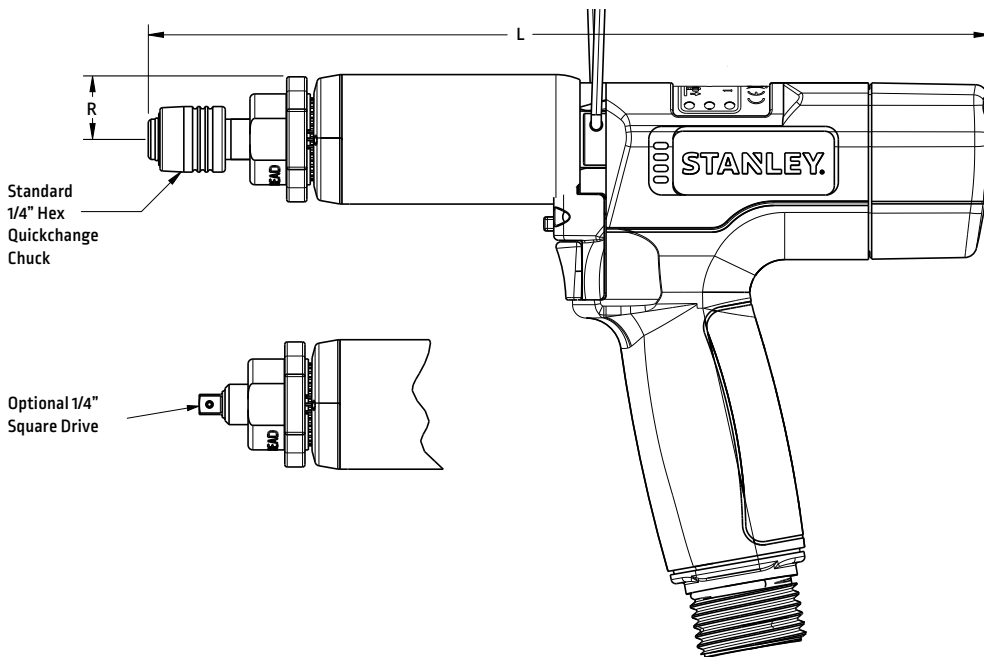

EB Pistol Tool Options

Output Options	Part No.
1/4" SD	20D119302
Reaction Bar	Part No.
Spacer	20D217000
Reaction Bar 17" Long	20K100103
Reaction Bar 12" Long	20K101601
Suspension Bail	Part No.
Wire Bail	A3061
Handle Grip	Part No.
Rubber Grip	20H207107

Cable Exit	Part No.
Top Exit EB1	20H106302

Optional Top Exit

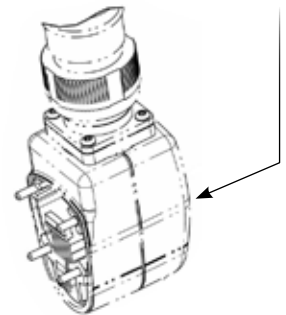

Requires EB Fixtured Whip Cable 20C1093XX

Model	Rated Speed		Max Torque		"R" Side to Center		"L" Length		Weight		Output
	RPM	Nm	lb ft	mm	in	mm	in	kg	lb	Standard	
EB12PP-2	1760	2	1.5	20	0.8	265	10.4	0.93	2	1/4 QC	
EB12PP-4	1115	4	2.9	20	0.8	265	10.4	0.93	2	1/4 QC	
EB12PP-6	2300	6	4.4	20	0.8	265	10.4	0.93	2	1/4 QC	
EB12PP-9	1595	9	6.6	20	0.8	265	10.4	0.93	2	1/4 QC	
EB12PP-14	1020	14	10.3	20	0.8	265	10.4	0.93	2	1/4 QC	

Mounting / Reaction Options

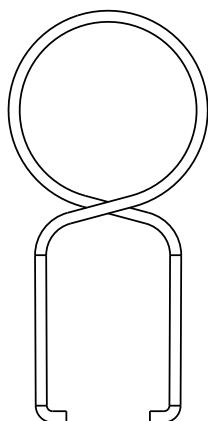

Wire Bail

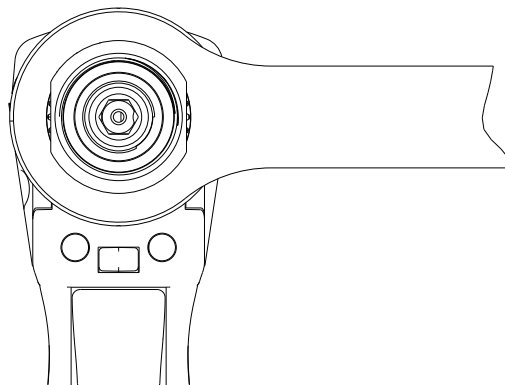

Reaction Bar

Optional Rubber Grip

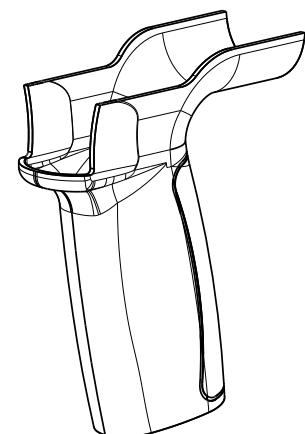

Inline Push-to-Start Lever Tools

0.4 to 14 Nm

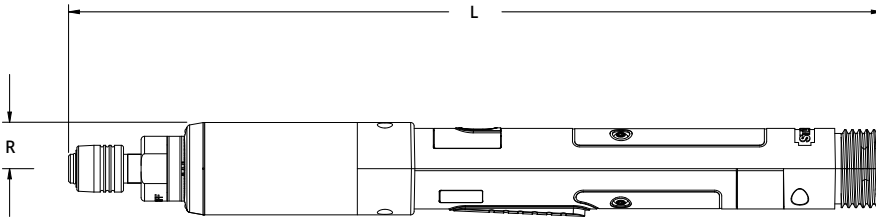

Model	Rated Speed		Max Torque		"R" Side to Center		"L" Length		Weight		Output
	RPM		Nm	lb ft	mm	in	mm	in	kg	lb	Standard
EB12LP-2	1760		2	1.5	20.4	0.8	359	14.1	0.85	1.87	1/4" QC
EB12LP-4	1115		4	2.9	20.4	0.8	359	14.1	0.85	1.87	1/4" QC
EB12LP-6	2300		6	4.4	20.4	0.8	359	14.1	0.85	1.87	1/4" QC
EB12LP-9	1595		9	6.6	20.4	0.8	359	14.1	0.85	1.87	1/4" QC
EB12LP-14	1020		14	10.3	20.4	0.8	359	14.1	0.85	1.87	1/4" QC

EB PTS Tool Options

EB12LP

Output Options	Part No.
1/4" Square Drive	20D119302
3/8" Square Drive (tools >5 Nm)	20D119301
3/8" SD Socket Lock Pin	Part No.
Standard	20D227800
Rounded (Ball Detent)	20D227801
Reaction Bar	Part No.
Reaction Bar, Aluminum 17"	20K100103
Reaction Bar, Steel 17"	20K100104
PTS Spline Cover	20D217001

Inline Lever Tools

0.4 to 14 Nm

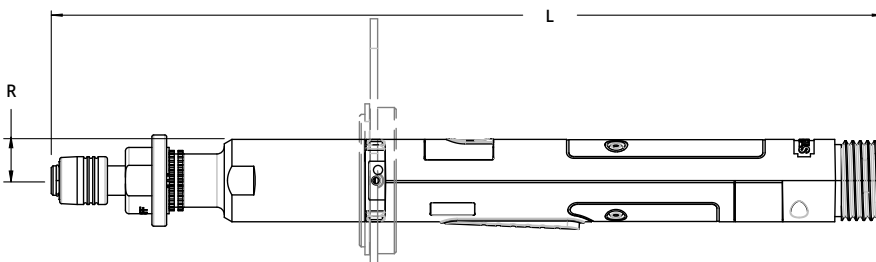

Model	Rated Speed		Max Torque		"R" Side to Center		"L" Length		Weight		Output
	RPM		Nm	lb ft	mm	in	mm	in	kg	lb	Standard
EB12LB-2	1760		2	1.5	17.8	0.7	359	14.1	0.69	1.52	1/4" QC
EB12LB-4	1115		4	2.9	17.8	0.7	359	14.1	0.69	1.52	1/4" QC
EB12LB-6	2300		6	4.4	17.8	0.7	359	14.1	0.69	1.52	1/4" QC
EB12LB-9	1595		9	6.6	17.8	0.7	359	14.1	0.69	1.52	1/4" QC
EB12LB-14	1020		14	10.3	17.8	0.7	359	14.1	0.69	1.52	1/4" QC

EB Inline Tool Options

EB12LB

Output Options	Part No.
3/8" Square Drive	20D119301
1/4" Square Drive	20D119302
3/8" SD Socket Lock Pin	Part No.
Standard	20D227800
Rounded (Ball Detent)	20D227801
Reaction Bar	Part No.
Reaction Bar, Aluminum	20K100103
Reaction Bar, Steel	20K100104
Suspension Bails	Part No.
Wire Bail	A3061
Swivel	20K101402

Inline Lever Tools

3.2 to 2000 Nm

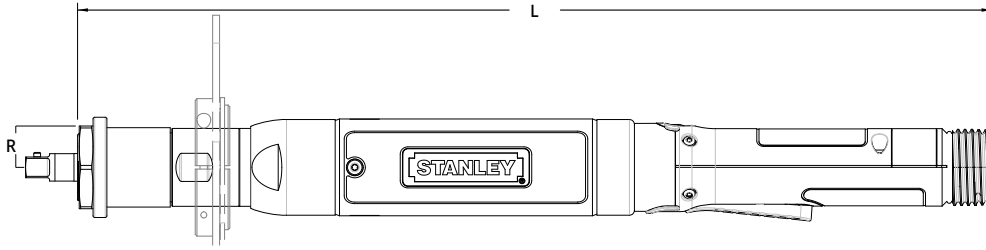

Model	Rated Speed		Max Torque		"R" Side to Center		"L" Length		Weight		Output
	RPM	Nm	lb ft	mm	in	mm	in	kg	lb	Standard	
EB22LB-16	1340	16	11.8	23.7	0.93	352	13.8	1.06	2.33	3/8" SD	
EB22LB-20	1071	20	14.8	23.7	0.93	365	14.4	1.10	2.40	3/8" SD	
EB33LB-28	1590	28	20.7	24.7	0.97	416	16.4	1.40	3.08	3/8" SD	
EB33LB-40	1120	40	29.5	24.7	0.97	416	16.4	1.40	3.08	3/8" SD	

Model	Rated Speed		Max Torque		"R" Side to Center		"L" Length		Weight		Output
	RPM	Nm	lb ft	mm	in	mm	in	kg	lb	Standard	
EB34LB1-55	830	55	40.6	26.7	1.05	463	18.2	2.04	4.49	1/2" SD	
EB44LB1-80	895	80	59	26.7	1.05	479	18.9	2.50	5.50	1/2" SD	
EB34LB1-75	545	75	55.3	26.7	1.05	491.51	19.35	2.04	4.49	1/2" SD	
EB55LB1-100	853	100	73.8	32	1.25	479	18.9	5.17	11.38	1/2" SD	
EB34LB1-105	410	105	77.5	26.7	1.05	491.51	19.35	2.04	4.49	1/2" SD	
EB44LB1-120	560	120	88.5	26.7	1.05	479	18.9	2.85	6.27	1/2" SD	
EB55LB2-120	850	120	88.5	32	1.25	564	22.2	5.17	11.40	3/4" SD	
EB45LB2-140	465	140	103.3	29	1.15	533	21	3.42	7.52	3/4" SD	
EB55LB2-170	640	170	125.4	32	1.25	560	22.1	4.62	10.18	3/4" SD	
EB45LB2-190	355	190	140.2	29	1.15	533	21	4.3	9.46	3/4" SD	
EB55LB2-250	400	250	184.4	32	1.25	560	22.1	4.93	10.85	3/4" SD	
EB55LB3-320	310	320	236	32	1.25	573	22.5	5.01	11.03	3/4" SD	
EB55LB4-460	220	460	339.3	44	1.7	621	24.4	7.60	16.73	1" SD	
EB55LB4-620	165	620	457.3	44	1.7	621	24.4	7.60	16.73	1" SD	
EB55LB5-800	125	800	590.1	48	1.9	651	25.6	10.05	22.12	1" SD	
EB55LB5-1100	80	1100	811.4	48	1.9	651	25.6	10.05	22.12	1" SD	
EB55LB5-1500	60	1500	1106.4	48	1.9	683	26.9	10.05	22.12	1" SD	
EB55LB5-2000	50	2000	1475.2	48	1.9	683	26.9	10.57	23.25	1" SD	

Mounting / Reaction Options

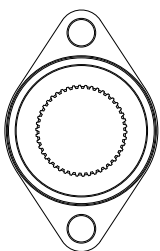

Optional Flange Mount Bracket



Reaction Bar or Bail

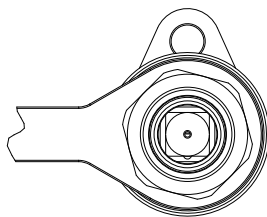

Optional Base Mount Bracket

EB Inline Tool Options

EB22, EB33

Output Options	Part No.
3/8" 24-Thread	20D281100
Reaction Bar	Part No.
Reaction Bar, Aluminum	F3698
Reaction Bar, Steel	20K100100
Base Mount Bracket	A8606
Mounting Flange-B	20K101000
3/8" SD Socket Lock Pin	Part No.
Standard	20D227800
Rounded (Ball Detent)	20D227801
Suspension Bails	Part No.
Wire Bail	A3061
Swivel	20K101400
Standard	B3432
Handle Options	Part No.
EB22 Forward Facing Lever	20H100108
EB3/4/5 Forward Facing Lever	20H100107

EB Inline Tool Options

EB34, EB44, EB45, EB55

Reaction Bar, LB1	Part No.
Reaction Bar Assembly	20K100000
Mounting Flange EB34, EB44	20K100400
Mounting Flange EB45, EB55	20K100700
Base Mount Bracket Assembly	20K100500
Suspension Bails	Part No.
Wire Bail	A3061
Swivel	20K200000
1/2" SD Socket Lock Pin	Part No.
Standard	20D227800
Rounded (Ball Detent)	20D227801
Handle Options	Part No.
EB22 Forward Facing Lever	20H100108
EB3/4/5 Forward Facing Lever	20H100107
Reaction Bar, LB2	Part No.
Reaction Bar Assembly	20K100200
Base Mount Bracket Assembly	20K100600
Mounting Flange	20K100700
Reaction Bar, LB3	Part No.
Reaction Bar Assembly	B4487
Base Mount Bracket Assembly	H1140
Mounting Flange	M4329
Reaction Bar, LB4	Part No.
Reaction Bar Assembly	F4192
Base Mount Bracket Assembly	F4201
Mounting Flange	20K101100
Reaction Bar, LB5	Part No.
Reaction Bar Assembly	F4192
Base Mount Bracket Assembly	F4201
Mounting Flange	20K100900

Crowfoot Lever Tools

1.6 to 49 Nm

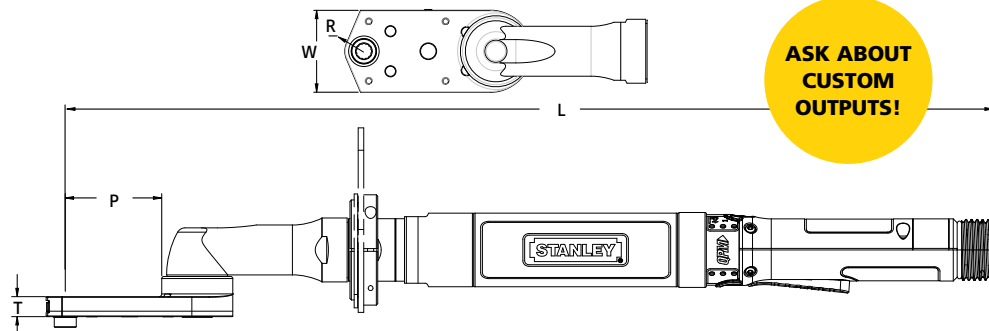

Crowfoot Tool Options

13Nm - 49Nm

Suspension Bails	Part No.
Wire Bail	A3061
Swivel Bail	20K101400
Standard Wire Bail	B3432

NOTE: The models listed below are the most common of the standard 278 Crowfoot outputs we produce. Contact STANLEY Assembly Technologies for the complete list or to discuss a custom output for your specific application.

ANGLE	Rated Speed	Max Torque		"R" Nose Radius		"T" Thickness		"W" Width		"P" Length		"L" Length		Weight		Maximum Hex Size	
Model	RPM	Nm	lb ft	mm	in	mm	in	mm	in	mm	in	mm	in	kg	lb	mm	in
EB12LC8-8	1065	8	5.9	13	0.52	16.2	0.64	25.4	1.00	44.6	1.76	382	15.0	1.1	2.4	13	1/2"
EB12LC106-8	1065	8	5.9	13	0.52	16.2	0.64	25.4	1.00	64.6	2.54	401	15.8	1.1	2.4	13	1/2"
EB12LC8-13	680	13	9.6	13	0.52	16.2	0.64	25.4	1.00	44.6	1.76	382	15.0	1.1	2.4	13	1/2"
EB12LC106-13	680	13	9.6	13	0.52	16.2	0.64	25.4	1.00	64.6	2.54	401	15.8	1.1	2.4	13	1/2"
EB12LC550-14	680	14	10.3	13	0.5	11.4	0.45	25.4	1.00	67.1	2.64	402	15.8	1.1	2.4	13	1/2"
EB22LC8-16	895	16	11.8	13	0.52	16.2	0.64	25.4	1.00	44.6	1.76	453	17.8	1.7	3.8	13	1/2"
EB22LC35-16	893	16	11.8	21	0.81	14	0.55	38	1.5	75	2.95	479.8	18.89	2.72	6	19	3/4"
EB33LC13-22	1310	22	16.3	13	0.52	20.6	0.81	31.8	1.25	47.3	1.86	530	20.8	2.5	5.5	13	1/2"
EB33LC216-27	990	27	19.9	13	0.5	15.0	0.59	31.8	1.25	47.3	1.86	530	20.8	2.5	5.5	13	1/2"
EB33LC563-27	990	27	19.9	13	0.52	15.9	0.63	31.8	1.25	47.3	1.86	530	20.8	2.5	5.5	13	1/2"
EB33LC301-27	991	27	19.9	13	0.53	16	0.63	32	1.25	47	1.86	463	18.23	2.72	6	13	1/2"
EB33LC13-30	840	30	22.1	13	0.52	20.6	0.81	31.8	1.25	47.3	1.86	530	20.8	2.5	5.5	13	1/2"
EB33LC173-30	990	30	22.1	13.5	0.53	15.9	0.63	31.8	1.25	93	3.66	590	23.2	2.5	5.5	13	1/2"
EB33LC362-30	932	30	22.1	13	0.5	16	0.63	26	1.02	66	2.59	549.1	21.62	2.72	6	13	1/2"
EB33LC246-33	880	33	24.3	16	0.63	20.6	0.81	31.8	1.25	48.3	1.90	531	20.9	2.9	6.4	14	9/16"
EB33LC16-35	881	35	25.8	21	0.81	21	0.84	38	1.5	75	2.95	558.1	21.97	2.59	5.7	19	3/4"
EB44LC508-35	1341	35	25.8	13	0.53	14	0.57	31.8	1.25	47	1.47	591	23.3	3.10	6.82	13	1/2"
EB33LC484-42	610	42	31	16	0.63	18.5	0.73	31.8	1.25	86.1	3.39	554	21.8	2.36	5.21	15	19/32"
VERTICAL																	
EB33LC624-28	1118	28	20.7	21	0.81	14	0.55	38	1.5	75	2.95	470.8	18.53	2.49	5.5	19	3/4"
EB34LC298-49	595	49	36.2	13	0.52	20.9	0.82	38.1	1.50	97.1	3.82	559	22.0	3.61	7.95	13	1/2"
INLINE																	
EB22LC521-30	475	30	22.1	13	0.53	16	0.63	32	1.25	45	1.76	419.3	16.51	1.83	4.03	13	1/2"
EB33LC521-30	739	30	22.1	13	0.53	16	0.63	32	1.25	45	1.76	498	19.61	1.9	4.19	13	1/2"

Mounting / Reaction Options

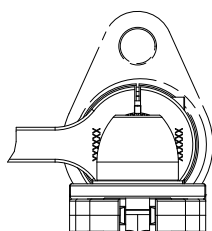

Reaction Bar or Bail



Sockets and Accessories
begin on page 92

2-Hand Anti-Tiedown Options

2-Hand Anti-Tiedown	Part No.
EB33 Tools	20H106400
EB34 Tools	20H106402
EB44 Tools	20H106403
EB45 Tools	20H106404
EB55 Tools	20H106401

Crowfoot Lever Tools

11.6 to 216 Nm

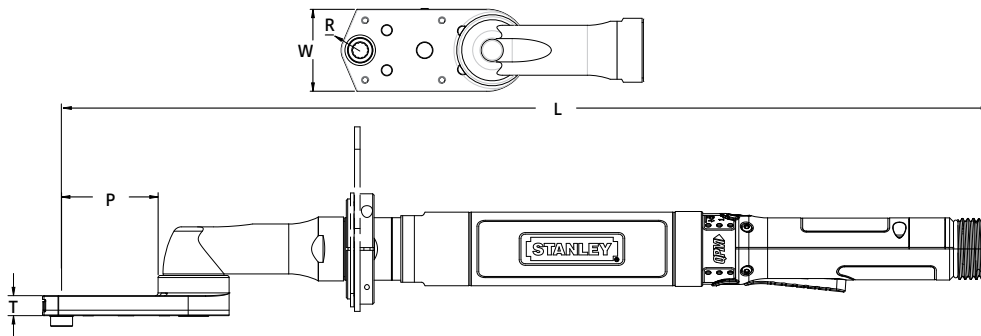

Crowfoot Tool Options

58Nm - 216Nm

Suspension Bails	Part No.
Wire Bail	A3061
Swivel Bail	20K200000
Reaction Bar	Part No.
Reaction Bar Assembly (Default)	20K100000
Mounting Flange EB33	20K100300
Mounting Flange EB34, EB44	20K100400
Mounting Flange EB45, EB55	20K100700
Base Mount Bracket Assembly	20K100500

ANGLE	Rated Speed	Max Torque		"R" Nose Radius		"T" Thickness		"W" Width		"P" Length		"L" Length		Weight		Maximum Hex Size	
Model	RPM	Nm	lb ft	mm	in	mm	in	mm	in	mm	in	mm	in	kg	lb	mm	in
EB34LC10-58	510	58	42.8	21	0.81	27.94	1.10	38.1	1.50	70.7	2.78	616	24.2	3.52	7.74	19	3/4"
EB34LC226-59	500	59	43.5	17	0.66	17	0.66	38	1.5	68	2.69	614	24.17	3.4	7.5	16	5/8"
EB33LC501-60	499	60	44.3	16.8	0.66	17	0.67	38.1	1.50	123	4.85	616	24.2	3.52	7.74	15	5/8"
EB34LC515-60	471	60	44.3	12	0.48	25	0.99	38	1.5	125	4.94	597.7	23.53	3.49	7.7	12	7/16"
EB34LC162-62	321	62	45.7	13	0.52	21	0.82	38	1.5	97	3.82	664.6	26.17	3.76	8.3	13	1/2"
EB34LC601-73	337	73	53.8	21	0.81	17	0.66	38	1.5	71	2.78	638.3	25.13	3.63	8	19	3/4"
EB44LC404-75	508	75	55.3	16.8	0.66	26.16	1.03	38.1	1.50	68.4	2.70	626	24.7	4.2	9.3	16	5/8"
EB45LC365-80	438	80	59	13	0.53	28	1.12	38	1.5	97	3.82	735	28.9	5.25	11.56	13	1/2"
EB45LC275-80	580	80	59	13	0.52	28	1.12	56	2.19	86	3.39	699.1	27.52	4.08	9	13	1/2"
EB45LC613-81	581	81	59.8	13	0.52	28.0	1.10	38.1	1.50	33.6	1.32	642	25.3	4.6	10.2	13	1/2"
EB45LC614-81	581	81	59.8	13	0.52	28.9	1.14	38.1	1.50	123	4.85	750	29.5	5.1	11.2	13	1/2"
EB45LC637-81	581	81	59.7	13	0.52	27	1.07	38	1.5	129	5.07	705.3	27.77	4.08	9	13	1/2"
EB44LC10-88	520	88	64.9	21	0.81	27.94	1.10	38.1	1.50	70.7	2.78	628	24.7	4.6	10.2	19	3/4"
EB44LC31-88	520	88	64.9	21	0.81	27.94	1.10	38.1	1.50	38.9	1.53	596	23.4	4.6	10.2	19	3/4"
EB44LC31-102	455	102	75.2	21	0.81	27.94	1.10	38.1	1.50	38.9	1.53	596	23.4	4.6	10.2	19	3/4"
EB44LC260-110	455	110	81.1	17	0.69	15	0.6	73	2.89	18	0.71	576.3	22.69	4.08	9	18	11/16"
EB34LC615-110	267	110	81.1	16	0.63	38.9	1.53	31.8	1.25	76.1	3.0	619.6	24.4	4.6	10.2	16	5/8"
EB45LC630-145	262	145	106.9	25	1	22	0.87	51	1.99	99	3.92	746.8	29.4	4.08	9	24	15/16"
EB55LC612-150	459	150	110.6	20	0.8	35	1.37	39	1.53	46	1.81	636.4	25.05	4.54	10	19	3/4"
EB55LC606-150	459	150	110.6	20	0.8	32.9	1.30	38.9	1.53	38.9	1.53	636.4	25.1	5.4	11.8	19	3/4"
EB55LC21-216	290	216	159.3	29	1.16	30.86	1.21	58.7	2.31	57.8	2.27	724	28.5	5.4	11.8	27	1-1/8"
EB55LC626-250	262	250	184.4	25	0.98	37.29	1.47	95.3	3.75	113.9	4.49	795.2	31.3	10.5	23.24	24	15/16"
VERTICAL																	
EB34LC586-74	408	74	54.6	21	0.81	27.94	1.10	38.1	1.50	70.7	2.78	564	22.2	3.8	8.3	19	3/4"
EB55LC625-237	309	237	174.8	25	0.98	40.89	1.61	95.3	3.75	113.9	4.49	809.8	31.9	11.4	25.23	24	15/16"

NOTE: The models listed are the most common of the standard 278 Crowfoot outputs we produce. Contact STANLEY Assembly Technologies for the complete list or to discuss a custom output for your specific application.

Mounting / Reaction Bail Options

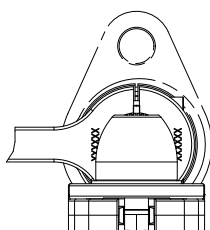

Reaction Bar or Bail

ASK ABOUT
CUSTOM
OUTPUTS!



Sockets and Accessories
begin on page 92

2-Hand Anti-Tiedown Options

2-Hand Anti-Tiedown	Part No.
EB33 Tools	20H106400
EB34 Tools	20H106402
EB44 Tools	20H106403
EB45 Tools	20H106404
EB55 Tools	20H106401

Tubenut Lever Tools

4.4 to 102 Nm

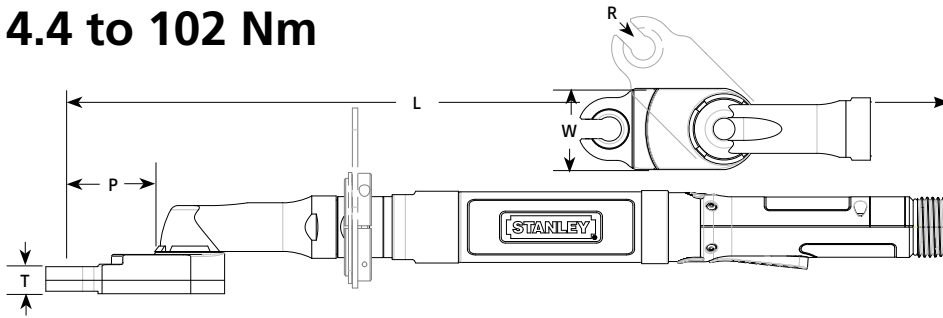

Tubenut Tool Options

25Nm - 41Nm

Suspension Bails	Part No.
Wire Bail	A3061
Swivel Bail	20K101400
Standard Wire Bail	B3432

ANGLE	Rated Speed		Max Torque		"R" Nose Radius		"T" Thickness		"W" Width		"P" Length		"L" Length		Weight		Maximum Hex Size		Maximum Tube Size	
	Model	RPM	Nm	lb ft	mm	in	mm	in	mm	in	mm	in	mm	in	kg	lb	mm	in	mm	in
EB33LT346-25	1165	25	18.4	13	0.52	14	0.54	42	1.7	34	1.3	511	20.1	2.34	5.15	13	0.5	9.3	0.365	
EB33LT572-25	1165	25	18.4	13	0.52	14	0.54	42	1.7	34	1.3	518	20.4	2.34	5.15	13	0.5	9.3	0.365	
EB33LT349-25	1165	25	18.4	38.1	1.5	14.1	0.56	42.2	1.66	55.6	2.19	539.7	21.25	2.27	5.01	13	0.5	9.3	0.365	
EB33LT387-25	1165	25	18.4	38.1	1.5	14.1	0.56	42.2	1.66	34	1.34	518.1	20.4	2.34	5.15	13	0.5	9.3	0.365	
EB33LT358-25	1165	25	18.4	13	0.52	14	0.54	42	1.66	34	1.34	518.1	20.4	2.31	5.1	13	0.5	9.3	0.365	
EB33LT641-25	1165	25	18.4	13	0.52	14	0.54	42	1.66	56	2.19	539	21.22	1.81	4	13	0.5	9.3	0.365	
EB33LT74-30	460	30	22.1	18	0.73	14	0.54	48	1.9	44	1.7	517	20.3	2.30	5.06	18	0.71	11.6	0.455	
EB33LT312-30	847	30	22.1	18	0.73	14	0.56	48	1.88	47	1.86	547.6	21.56	1.81	4	18	0.71	11.6	0.455	
EB33LT473-30	965	30	22.1	18.4	0.73	14.3	0.56	57.2	2.25	38.9	1.53	533.5	21	2.75	6.06	18	0.71	11.6	0.455	
EB33LT527-30	881	30	22.1	18.4	0.73	15.9	0.62	47.7	1.88	16.3	0.64	500.6	19.71	2.3	5.06	18	0.71	11.6	0.455	
EB33LT375-41	710	41	30.2	13	0.52	22	0.85	44	1.7	59	2.3	466	8.3	2.48	5.45	13	0.5	9.3	0.365	
EB33LT621-41	719	41	30.2	15.9	0.63	20.3	0.8	52.4	2.06	26.4	1.04	521	20.51	2.5	5.5	15	0.59	10.4	0.41	
EB34LT23-41	695	41	30.2	18	0.73	23	0.91	48	1.88	44	1.72	580.9	22.87	1.64	3.61	18	0.71	11.6	0.455	
EB34LT623-57	480	57	42	26.4	1.04	19.4	0.765	74.6	2.94	60.7	2.39	603.8	23.73	4.13	9.1	27	1.06	19.4	0.765	
EB34LT99-62	460	62	45.7	26	1.04	20	0.76	75	2.9	65	2.5	604	23.8	2.93	6.45	27	1.06	19.4	0.765	
EB44LT20-102	430	102	75.2	26	1.04	32	1.24	75	2.9	65	2.5	628	24.7	4.46	9.82	27	1.06	19.4	0.765	
EB55LT424-180	325	180	132.8	31	1.22	30	1.18	100	3.94	74	2.91	740.1	29.14	8.32	18.34	32	1.25	20	0.801	
INLINE																				
EB22LT252-25	500	25	18.4	13	0.52	14	0.54	42	1.7	56	2.2	434	17.1	1.79	3.93	13	0.5	9.3	0.365	
EB22LT571-25	500	25	18.4	13	0.52	14	0.54	42	1.7	56	2.2	434	17.1	1.79	3.93	13	0.5	9.3	0.365	
EB33LT252-25	739	25	18.4	38.1	1.5	14.1	0.56	42.2	1.66	55.9	2.2	512.7	20.19	1.95	4.3	13	0.5	9.3	0.365	
EB33LT326-25	739	25	18.4	13.1	0.515	14.1	0.56	42.2	1.66	77.5	3.05	534.3	21.04	1.95	4.3	13	0.5	8.1	0.32	
EB33LT264-50	422	50	36.9	21.4	0.84	17.5	0.69	54	2.13	78.8	3.1	535.7	21.09	1.95	4.3	24	0.94	13.6	0.535	
VERTICAL																				
EB34LT150-30	945	30	22.1	18	0.73	14	0.56	48	1.9	47	1.9	521	20.5	2.73	5.99	19	0.75	11.6	0.455	

The maximum tube size depends on the chosen HEX size. NOTE: The models listed are the most common of the standard 104 Tubenut outputs we produce. Contact STANLEY Assembly Technologies for the complete list or to discuss a custom output for your specific application.

Mounting / Reaction Options

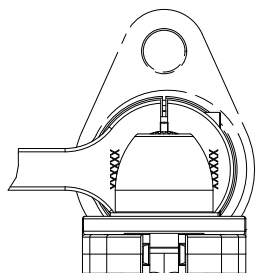

Reaction Bar or Bail



Sockets and Accessories
begin on page 92

Tubenut Tool Options

30Nm - 102Nm

Suspension Bails	Part No.
Wire Bail	A3061
Swivel Bail	20K200000
Reaction Bar	Part No.
Reaction Bar Assembly (Default)	20K100000
Mounting Flange EB33	20K100300
Mounting Flange EB33, EB44	20K100400
Base Mount Bracket Assembly	20K100500

Hold and Drive Lever Tools – 1" Output

9.2 to 380 Nm

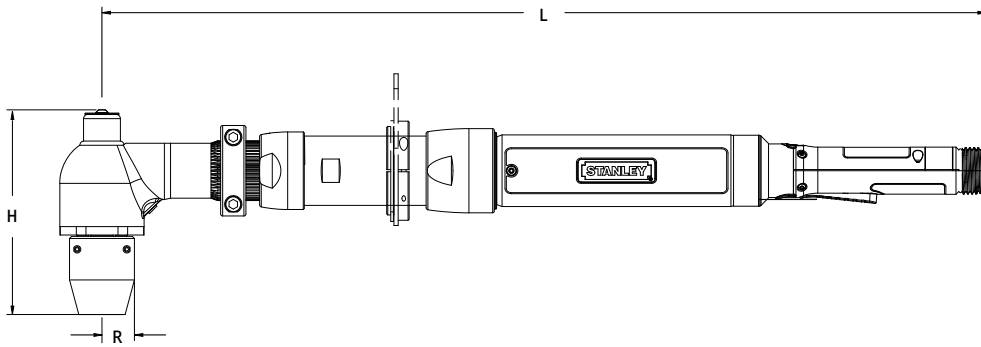

Model	Rated Speed		Max Torque		"R" Side to Center		"H" Head Height		"L" Length		Weight		Travel
	RPM	Nm	lb ft	mm	in	mm	in	mm	in	kg	lb		
EB33LH18V1-46	880	46	33.9	18	0.71	131.9	5.2	464	18.3	2.2	4.9	1"	
EB34LH22AV1-77	510	77	56.8	22	0.87	143.8	5.7	521	20.5	3.4	7.5		
EB34LH22AV1-110	335	110	81.1	22	0.87	143.8	5.7	543	21.4	3.4	7.5		
EB55LH26V1-150	620	150	110.6	26	1.02	142.8	5.6	637	25.1	5.8	12.8		
EB45LH26V1-155	400	155	114.3	26	1.02	142.8	5.6	582	22.9	5.5	12.1		
EB45LH26V1-220	260	220	162.3	26	1.02	142.8	5.6	582	22.9	5.5	12.1		
EB55LH32V1-285	340	285	210.2	32	1.3	179.6	7.1	639	25.1	6.2	13.6		
EB55LH32V1-380	225	380	280.3	32	1.3	179.6	7.1	639	25.1	6.2	13.6		

A Tang holds the bolt while the nut is tightened



NOTE: The bolt can extend beyond the nut no more than the specified travel distance when tightened.

1" DC H&D Lever Tool Options

H32 Tang Holder	Part No.
Female Tang Holder Options	20D900601
H32 Bit Holder	Part No.
Bit Holder Options	20D900602
H32 Reaction Bar	Part No.
Reaction Bar Assembly	20K100200
Mounting Flange Assembly	20K100700
Base Mount Bracket Assembly	20K100600
Reaction Bar Assembly, HD	20K100202

See pages 106-117 for the Hold and Drive Configuration Guide

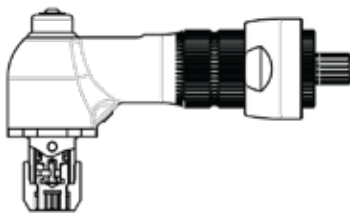

Sockets and Accessories begin on page 92

1" H&D Lever Tool Options

H18 Output	Part No.
Socket Options	20D905700
1" Travel Bit Holder Output	20D124600
1" Travel Tang Holder Output	20D124602
H18 Tang Holder	Part No.
6mm x 8mm Rectangle	20D261700
5mm x 7.5mm Rectangle	20D261701
6mm x 10mm Rectangle	20D261702
6mm Hex	20D261703
H18 Bit Holder	Part No.
1/4" Hex	20D254200
5/16" Hex	20D253400
H22 Output	Part No.
Socket Options	-N4617
1" Travel Tang Holder Output	20D103211
1" Travel Bit Holder Output	20D103212
H22 Tang Holder	Part No.
Female Tang Holder Options	-F4287
H22 Bit Holder	Part No.
Bit Holder Options	-F4288
H22 Reaction Bar	Part No.
Reaction Bar Assembly (Default)	20K100000
Mounting Flange Assembly	20K100300
Base Mount Bracket Assembly	20K100500
H26 Output	Part No.
Socket Options	-F4285
1" Travel Tang Holder Output	20D103601
1" Travel Bit Holder Output	20D103602
H26 Tang Holder	Part No.
Female Tang Holder Options	-H4948
H26 Bit Holder	Part No.
Bit Holder Options	-H4947
H26 Reaction Bar	Part No.
Reaction Bar Assembly	20K100200
Mounting Flange Assembly	20K100700
Base Mount Bracket Assembly	20K100600
Reaction Bar Assembly, HD	20K100202
H32 Output	Part No.
Socket Options	-A5302
1" Travel Tang Holder Output	20D103701
1" Travel Bit Holder Output	20D103702
Handle Options	Part No.
EB3/4/5 Forward Facing Lever	20H100107

Hold and Drive Lever Tools – 2" Output

9.2 to 380 Nm

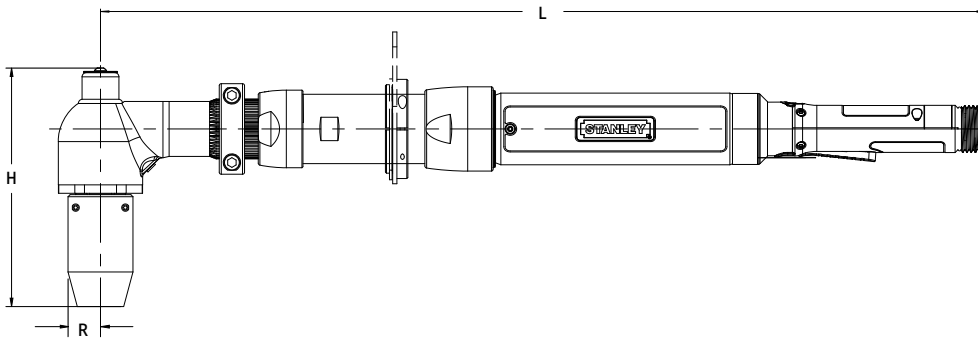

Model	Rated Speed		Max Torque		"R" Side to Center		"H" Head Height		"L" Length		Weight		Travel
	RPM	Nm	lb ft	mm	in	mm	in	mm	in	kg	lb	Standard	
EB33LH18V2-46	880	46	33.9	18	0.71	190.3	7.5	464	18.3	2.1	4.6	2"	
EB34LH22AV2-77	510	77	56.8	22	0.87	199.0	7.8	521	20.5	3.1	6.8		
EB34LH22AV2-110	335	110	81.1	22	0.87	199.0	7.8	543	21.4	3.1	6.8		
EB45LH26V2-155	400	155	114.3	26	1.02	168.2	6.6	582	22.9	4.6	10.0		
EB55LH26V2-210	460	210	154.9	26	1.02	168.2	6.6	637	25.1	5.8	12.8		
EB45LH26V2-220	260	220	162.3	26	1.02	168.2	6.6	582	22.9	4.6	10.0		
EB55LH32V2-285	340	285	210.2	32	1.3	205	8.1	639	25.1	6.2	13.6		
EB55LH32V2-380	225	380	280.3	32	1.3	205	8.1	639	25.1	6.2	13.6		

A Bit holds the bolt while the nut is tightened

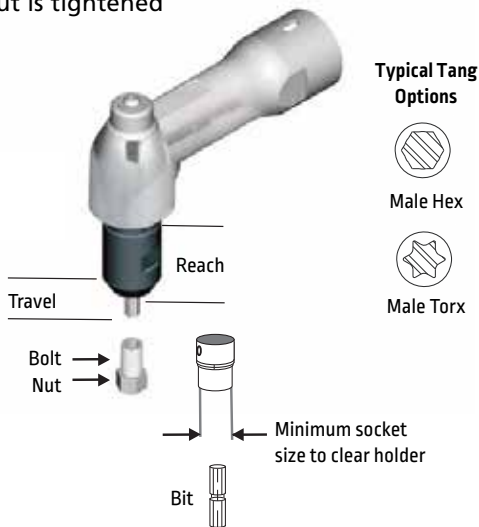

2" DC H&D Lever Tool Options

H32 Tang Holder	Part No.
Female Tang Holder Options	20D900601
H32 Bit Holder	Part No.
Bit Holder Options	20D900602
H32 Reaction Bar	Part No.
Reaction Bar Assembly	20K100200
Mounting Flange Assembly	20K100700
Base Mount Bracket Assembly	20K100600
Reaction Bar Assembly, HD	20K100202

See pages 106-117 for the Hold and Drive Configuration Guide

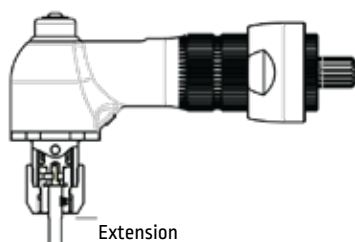

Sockets and Accessories begin on page 92

2" H&D Lever Options

H18 Output	Part No.
Socket Options	20D905700
2" Travel Bit Holder Output	20D124601
2" Travel Tang Holder Output	20D124603
H18 Tang Holder	Part No.
6mm x 8mm Rectangle	20D261700
5mm x 7.5mm Rectangle	20D261701
6mm x 10mm Rectangle	20D261702
6mm Hex	20D261703
H18 Bit Holder	Part No.
1/4" Hex	20D254200
5/16" Hex	20D253400
H22 Output	Part No.
Socket Options	-N4617
2" Travel Tang Holder Output	20D103213
2" Travel Bit Holder Output	20D103214
H22 Tang Holder	Part No.
Female Tang Holder Options	-F4287
H22 Bit Holder	Part No.
Bit Holder Options	-F4288
H22 Reaction Bar	Part No.
Reaction Bar Assembly (Default)	20K100000
Mounting Flange Assembly	20K100300
Base Mount Bracket Assembly	20K100500
H26 Output	Part No.
Socket Options	-F4285
2" Travel Tang Holder Output	20D103603
2" Travel Bit Holder Output	20D103604
H26 Tang Holder	Part No.
Female Tang Holder Options	-H4948
H26 Bit Holder	Part No.
Bit Holder Options	-H4947
H26 Reaction Bar	Part No.
Reaction Bar Assembly	20K100200
Mounting Flange Assembly	20K100700
Base Mount Bracket Assembly	20K100600
Reaction Bar Assembly, HD	20K100202
H32 Output	Part No.
Socket Options	-A5302
2" Travel Tang Holder Output	20D103703
2" Travel Bit Holder Output	20D103704
Handle Options	Part No.
EB3/4/5 Forward Facing Lever	20H100107



EB-Series Corded Fixtured Tools

High Speed, Redundant Transducer and Flexible Cable connections.

FEATURES AND BENEFITS:

- Controllers Enable Multiple Spindle Operation Including Synchronization.
- Redundant Transducer Optional
- 360° Viewable High / OK / Low Lights Alert
- Operator to Fastening Status
- Fixtured Tool Cable Connector can be Rotated in 90° Increments.



OUTPUT OPTIONS

Angle



Retractable Angle



Straight

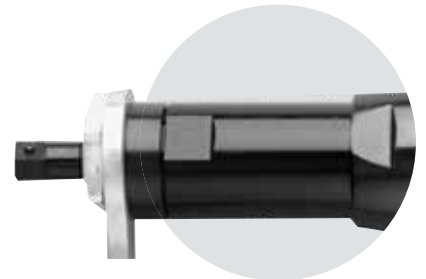

Retractable Straight



REACTION MOUNTING COMPONENTS



Retractable Offset

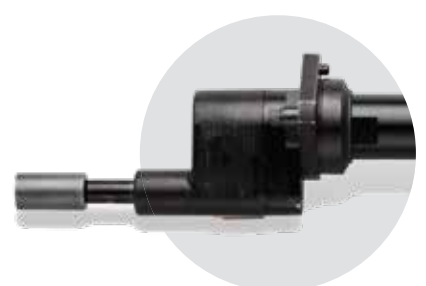

EB-Series Torque Range: Fixtured Style

Angle Fixtured Mount Style

MODELS:

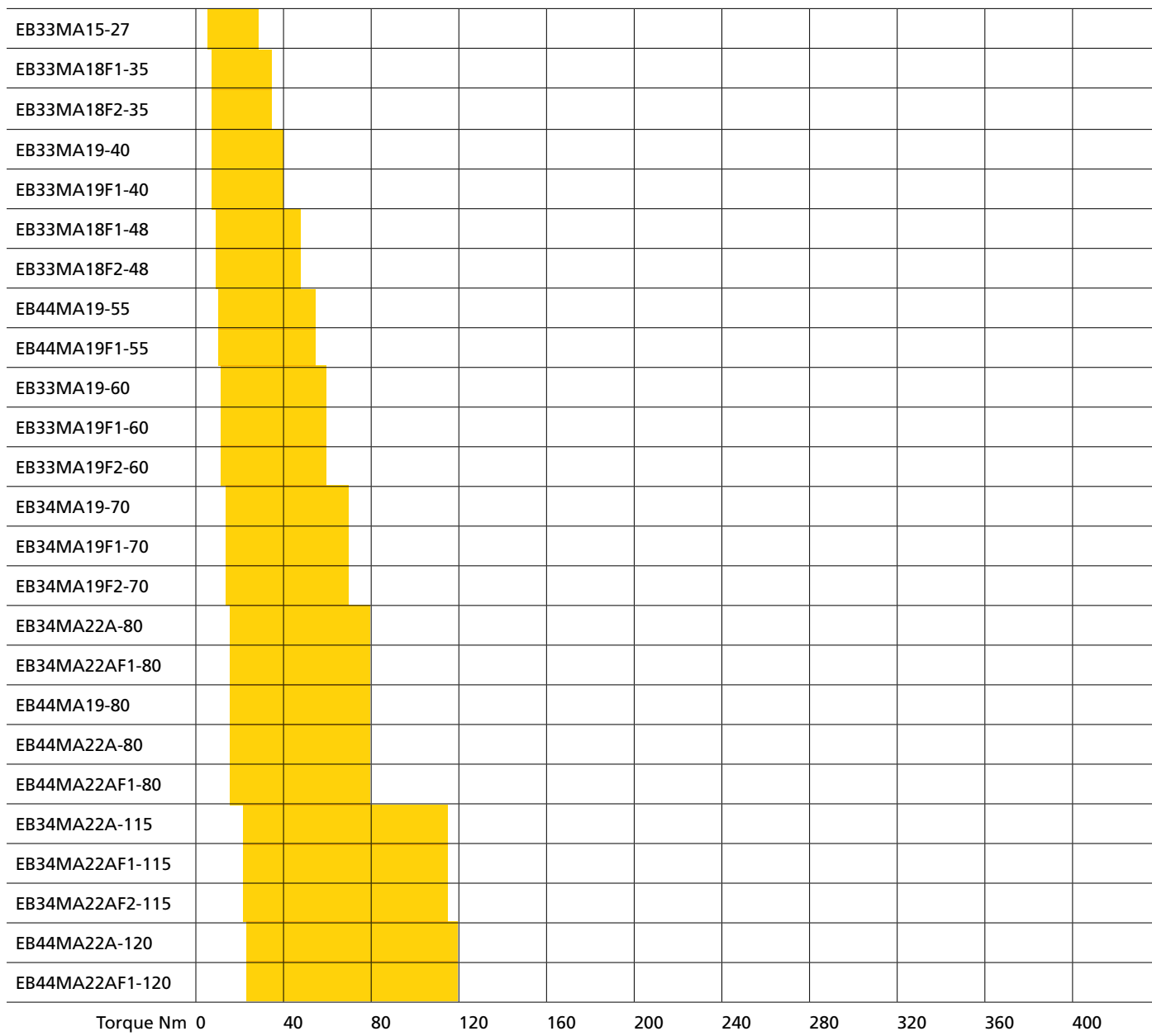

Please Note: This chart is a guide for the use of our tools. Programming of these tools can have a direct effect on the capability and performance.

Angle Fixtured Mount Style, *continued*

MODELS:

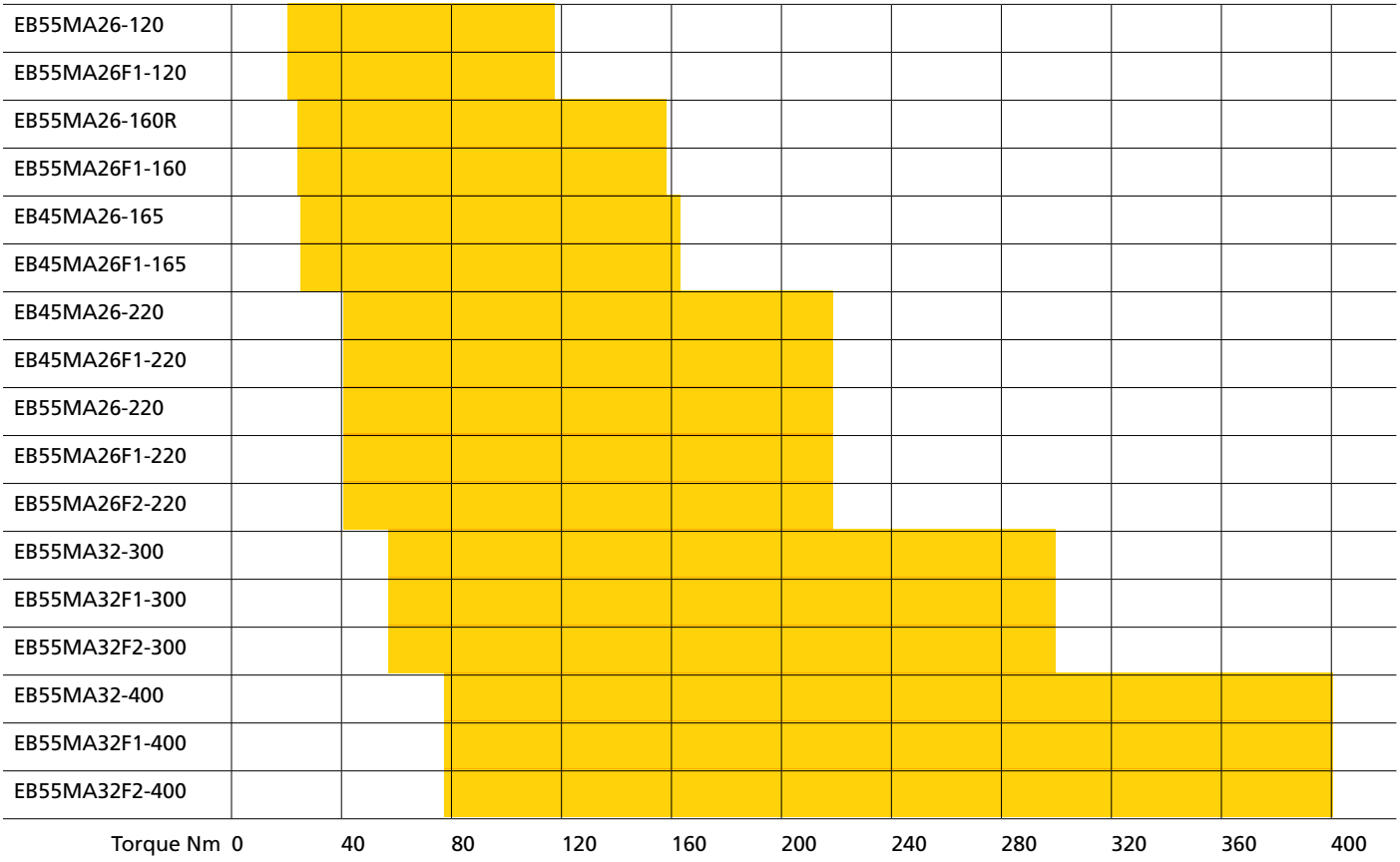

Please Note: This chart is a guide for the use of our tools. Programming of these tools can have a direct effect on the capability and performance.

Inline Fixtured Mount Style

MODELS:

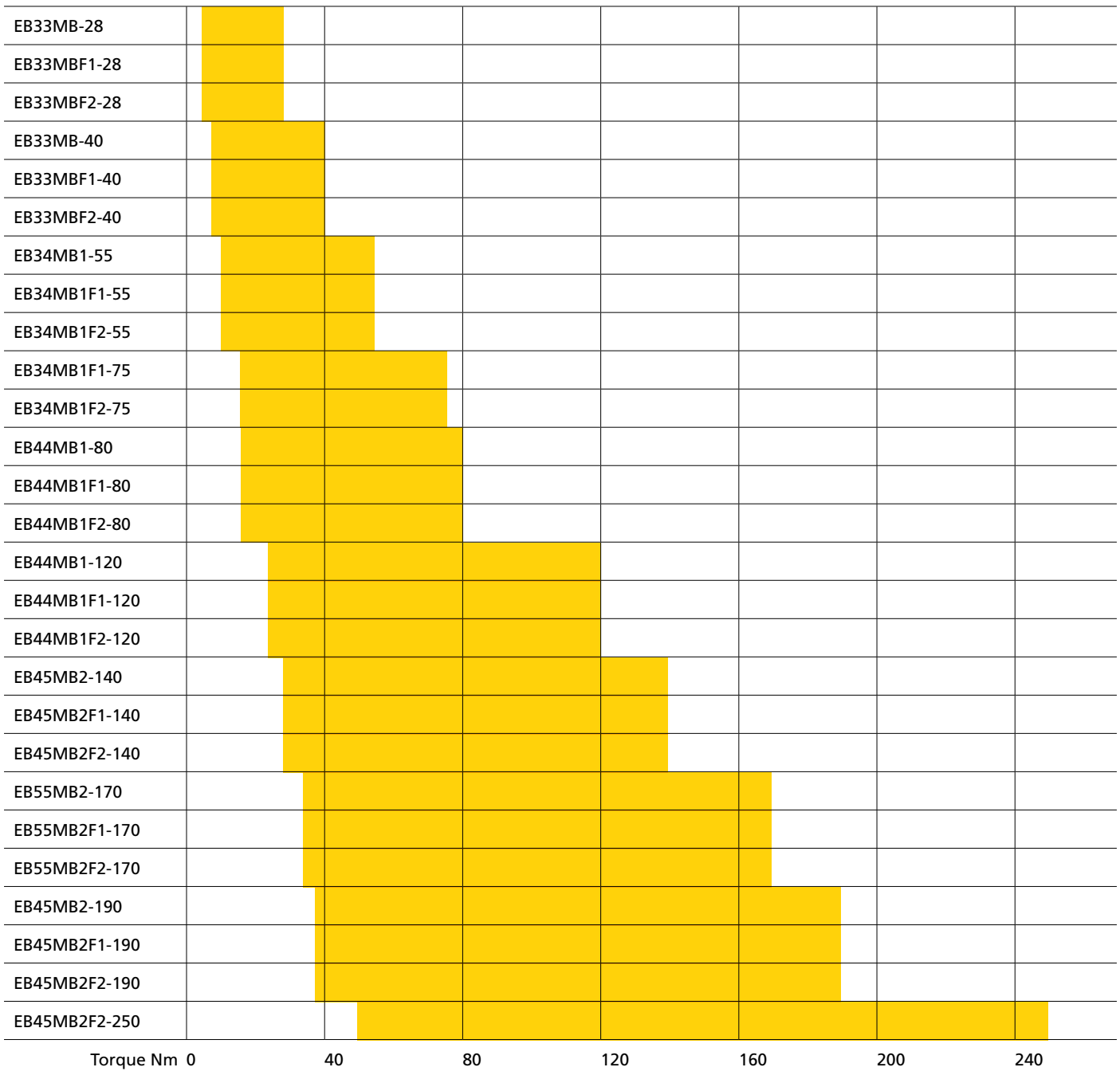

Please Note: This chart is a guide for the use of our tools. Programming of these tools can have a direct effect on the capability and performance.

Inline Fixtured Mount Style, *continued*

MODELS:

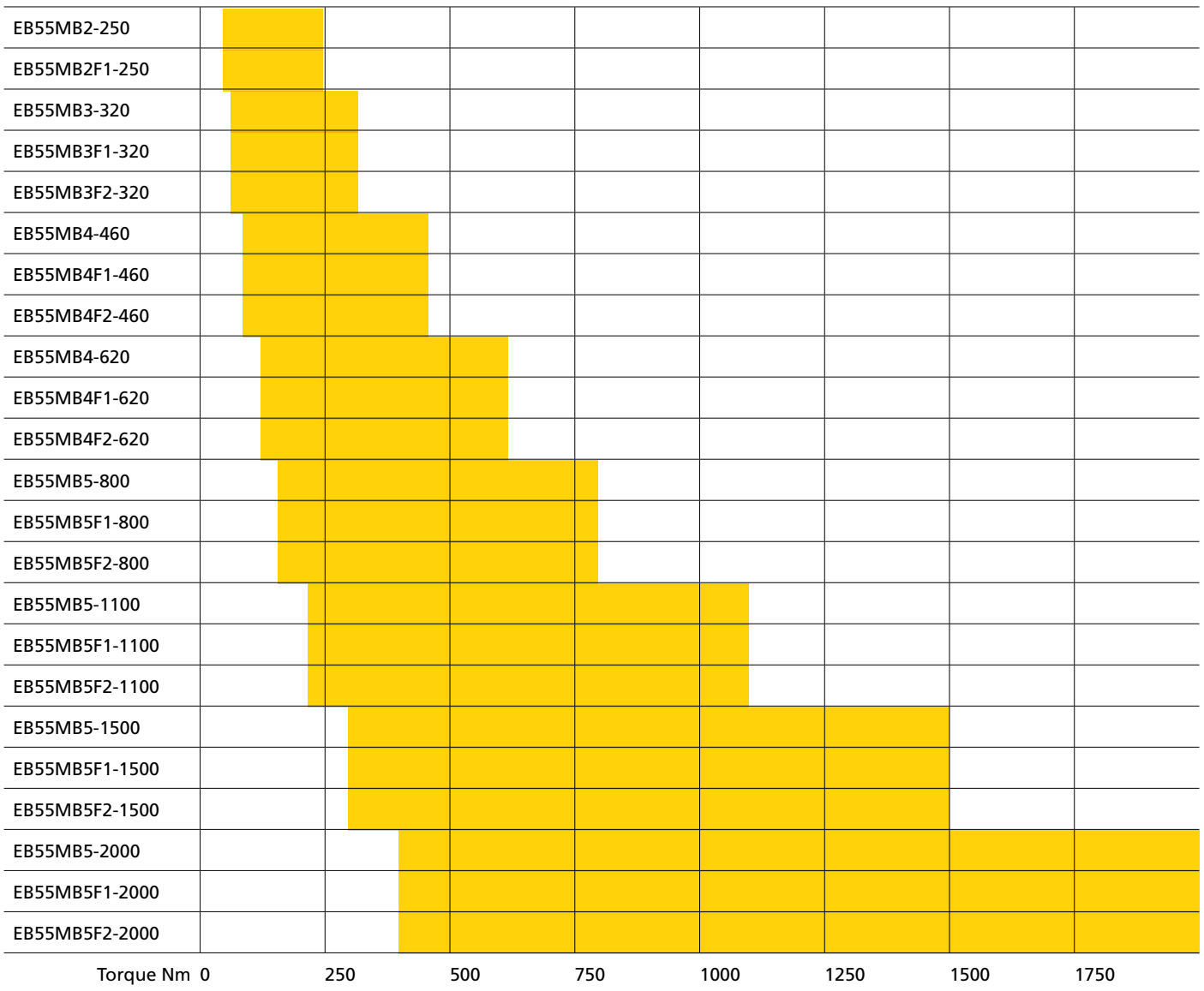

Please Note: This chart is a guide for the use of our tools. Programming of these tools can have a direct effect on the capability and performance.

Offset Fixtured Mount Style

MODELS:

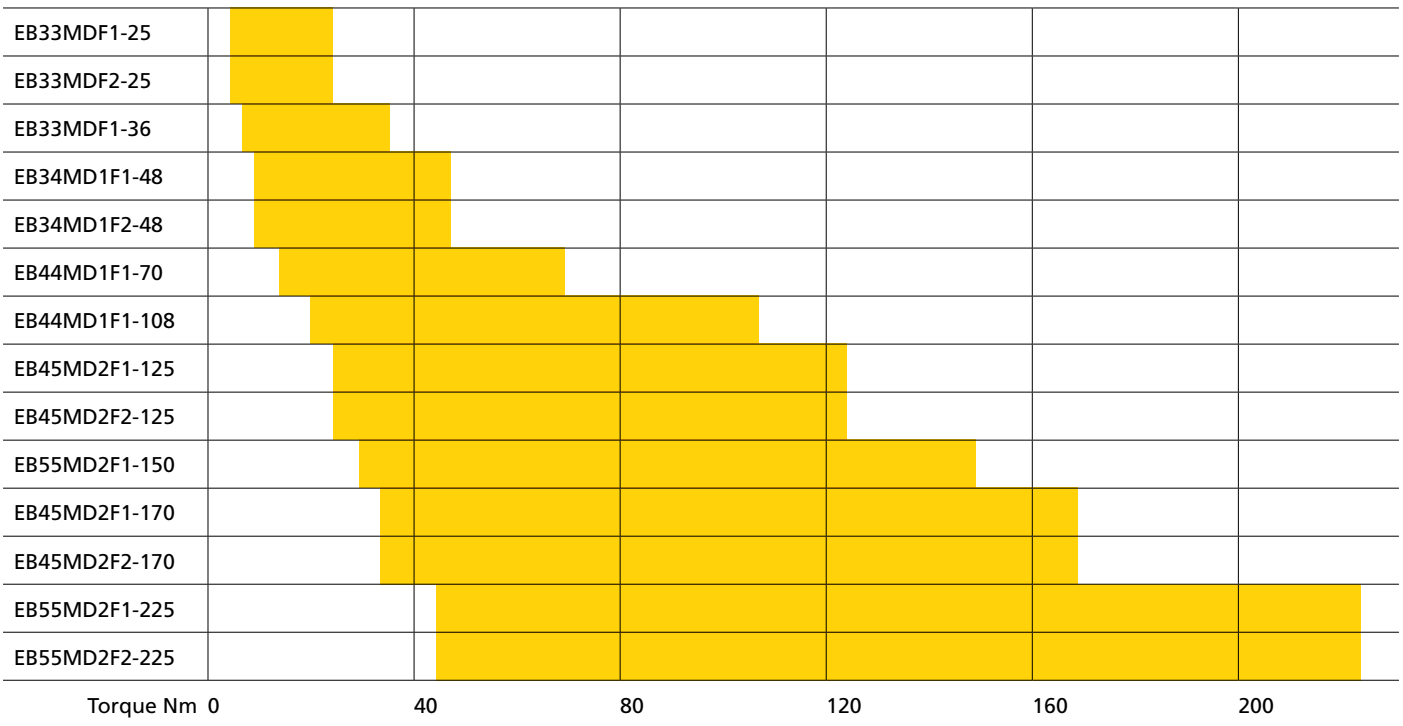

Hold and Drive Fixtured Mount Style

MODELS:

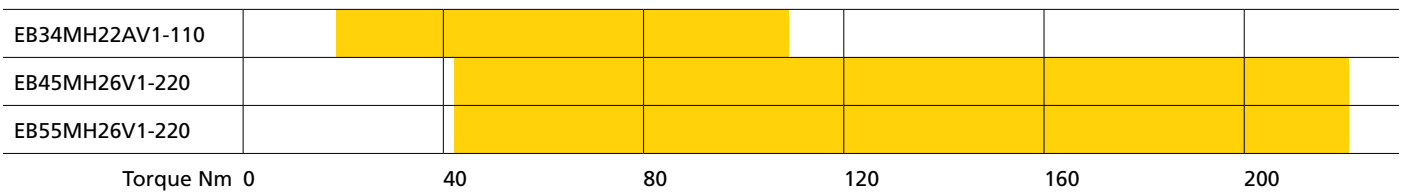

Please Note: These charts are a guide for the use of our tools. Programming of these tools can have a direct effect on the capability and performance.

Fixtured Tools Pattern Mounting

Examples of how to create unique square or circular bolt patterns for Inline and Offset Retractable tools:

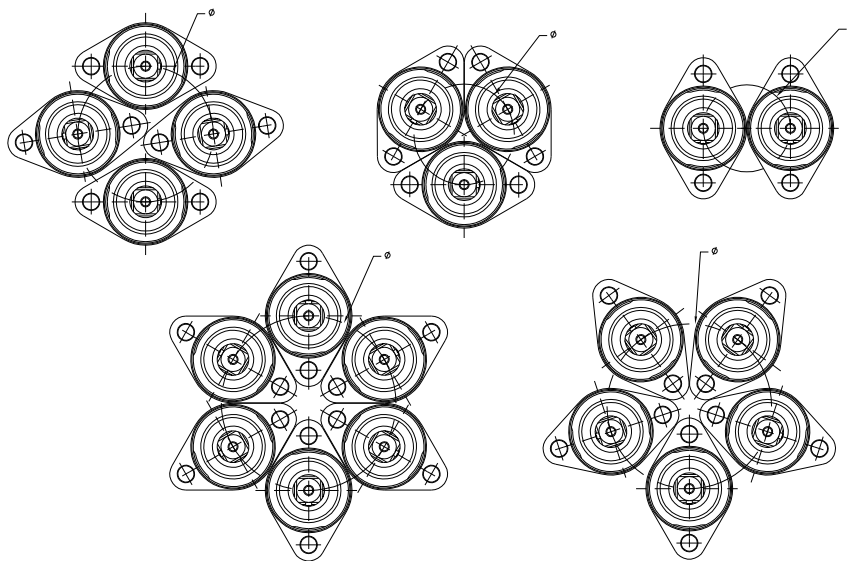
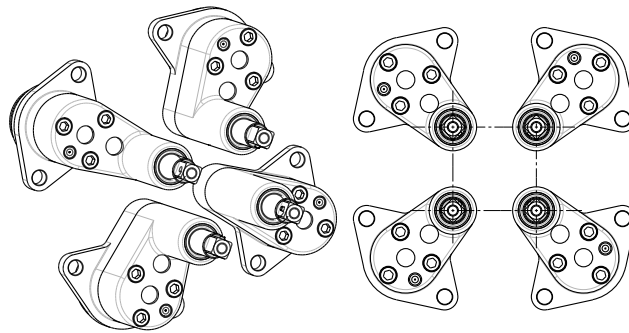
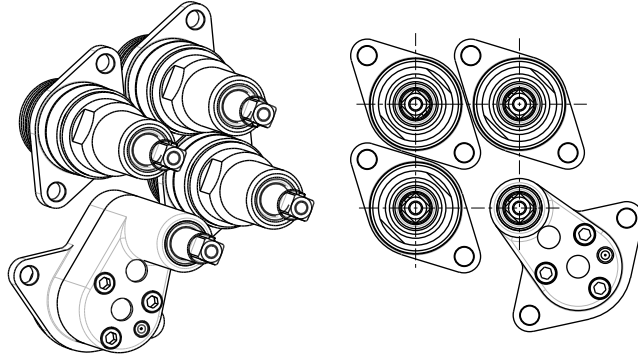

Angle Fixtured Tools

8 to 60 Nm

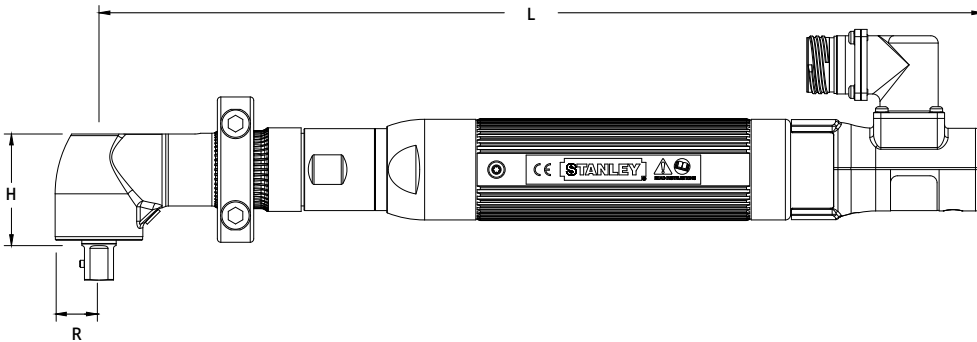

Model	Rated Speed		Max Torque		"R" Side to Center		"H" Head Height		"L" Length		Weight		Output
	RPM	Nm	lb ft	mm	in	mm	in	mm	in	kg	lb	Standard	
EB33MA15-27	1515	27	19.9	15	0.59	36.6	1.44	382.9	15.1	1.7	3.75	3/8" SD	
EB33MA19-40	1025	40	29.5	19	0.75	48.7	1.92	385.8	15.2	1.9	4.11	1/2" SD	
EB33MA18F0-48	881	48	35.4	17.5	0.69	39.3	1.55	382.8	15.1	2.41	5.31	3/8" SD	
EB33MA19-60	680	60	44.2	19	0.75	48.7	1.92	385.8	15.2	2.31	5.10	1/2" SD	

Angle Fixtured Options

EB33

A19 Threaded Output	Part No.
Flush Socket	20D100021
Suspension Bails	Part No.
Wire Bail	A3061
Swivel	20K200000
Standard	B3432
Reaction Device	Part No.
Reaction Bar, Steel (Default)	20K100000
Base Mount Bracket	20K100500
Mounting Flange-B	20K100300

**Due to the welded flange, the above options are not applicable to EB33MA18F0-48.*

Mounting / Reaction Options

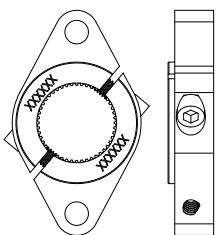

Optional Flange Mount Bracket

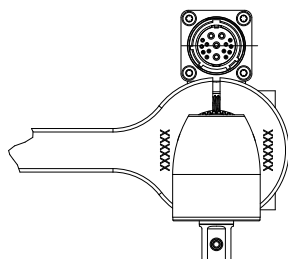

Standard Reaction Bar

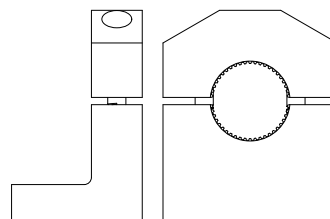

Optional Base Mount Bracket



Sockets and Accessories
begin on page 92

Angle Fixtured Tools

24 to 400 Nm

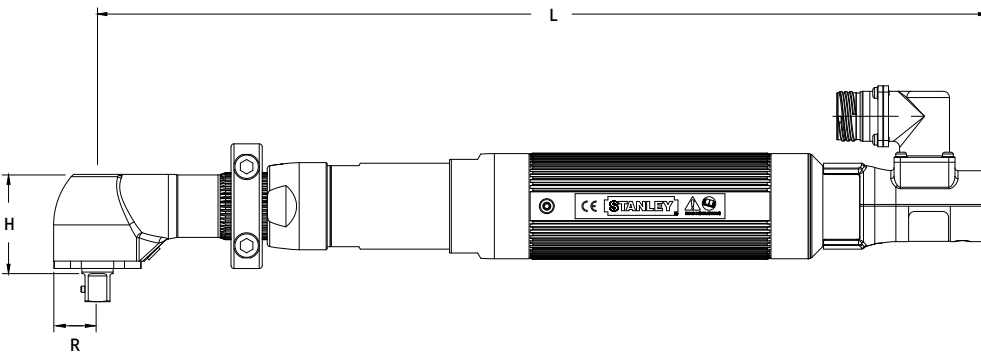

Model	Rated Speed		Max Torque		"R" Side to Center		"H" Head Height		"L" Length		Weight		Output
	RPM	Nm	lb ft	mm	in	mm	in	mm	in	kg	lb	Standard	
EB44MA19-55	1190	55	40.6	19	0.75	48.7	1.92	445	7.5	3.2	6.97	1/2" SD	
EB34MA19-70	610	70	51.6	19	0.75	48.7	1.92	433	17.0	3.2	6.97		
EB34MA22A-80	510	80	59.0	22	0.87	50.0	2.00	441	17.4	3.1	6.82		
EB44MA19-80	845	80	59.0	19	0.75	48.7	1.92	445	17.5	3.2	6.97		
EB44MA22A-80	810	80	59.0	22	0.87	50.0	2.00	453	17.8	3.1	6.82		
EB34MA22A-115	340	115	84.8	22	0.87	50.0	2.00	463	18.2	3.5	7.75		
EB44MA22A-120	550	120	88.5	22	0.87	50.0	2.00	453	17.8	3.53	7.8		

Angle Fixtured Options

EB34, EB44

A19 Splined Output	Part No.
Anti-Vibration 1/2" SD	20D100101
Flush Socket	20D100106
1/2" Double-Ended, RH Thread*	20D100107
A22A Output	Part No.
Flush Socket	20D100309
1/2" Double-Ended, RH Thread*	20D100326
Reaction Device	Part No.
Reaction Bar, Steel (Default)	20K100000
Base Mount Bracket	20K100500
Mounting Flange	20K100302
1/2" SD Socket Lock Pin	Part No.
Standard	20D227800
Rounded (Ball Detent)	20D227801

*RH-Thread is Right-Hand Thread. This is an option used if the end user uses the additional output for clockwise tightening or loosening.

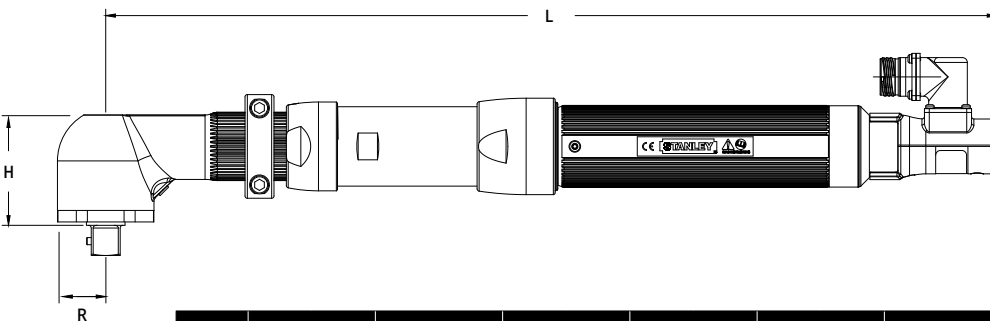

Model	Rated Speed		Max Torque		"R" Side to Center		"H" Head Height		"L" Length		Weight		Output
	RPM	Nm	lb ft	mm	in	mm	in	mm	in	kg	lb	Standard	
EB55MA26-120	825	120	88.5	26	1.02	60	2.4	557	21.9	6.2	13.6	3/4" SD	
EB55MA26-160	620	160	118	26	1.02	60	2.4	557	21.9	6.2	13.6		
EB45MA26-165	400	165	122	26	1.02	60	2.4	503	19.8	4.6	10.0		
EB45MA26-220	260	220	162	26	1.02	60	2.4	527	20.7	4.6	10.0		
EB55MA26-220	460	220	162	26	1.02	60	2.4	556	21.9	6.7	14.7		
EB55MA32-300	340	300	221	32	1.3	73	2.9	563	22.1	7.3	16.1		
EB55MA32-400	225	400	295	32	1.3	73	2.9	563	22.1	7.3	16.1		

Angle Fixtured Options

EB45, EB55

A26 Output	Part No.
Flush Socket	20D100409
5/8" Square Drive	20D100400
Reaction Device	Part No.
Reaction Bar, Steel (Default)	20K100200
Reaction Bar, Steel, Heavy Duty	20K100202
Base Mount Bracket	20K100600
Mounting Flange-B	20K100700
3/4" SD Socket Lock Pin	Part No.
Standard	20D125200
Rounded (Ball Detent)	20R202300



Sockets and Accessories
begin on page 92

Angle Retractable Fixtured Tools

8 to 120 Nm

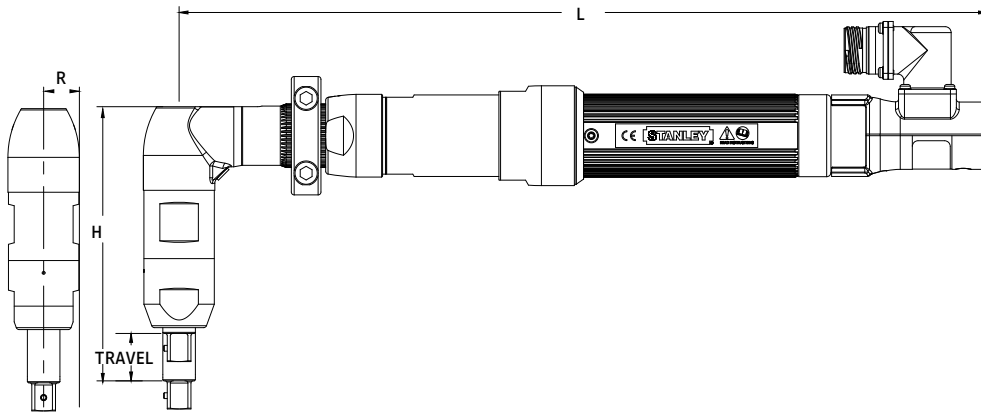

Model	Rated Speed		Max Torque		"R" Side to Center		"H" Head Height		"L" Length		Weight		Output	
	RPM	Nm	lb ft	mm	in	mm	in	mm	in	kg	lb	Retraction	Standard	
EB33MA18F1-35	1165	35	25.8	18	0.71	84	3.3	462.74	18.22	3.25	7.2	25 mm 1"	3/8" SD	
EB33MA19F1-40	1025	40	29.5	19	0.75	146.5	5.8	385	15.1	2.80	6.15		1/2" SD	
EB33MA18F1-48	880	48	35.4	18	0.71	84	3.3	462.74	18.22	3.25	7.2		3/8" SD	
EB44MA19F1-55	1190	55	40.6	19	0.75	146.5	5.8	445	17.5	3.18	7.02		1/2" SD	
EB33MA19F1-60	680	60	44.2	19	0.75	146.5	5.8	385	15.1	2.80	6.15		1/2" SD	
EB34MA19F1-70	610	70	51.6	19	0.75	146.5	5.8	433	17.0	2.74	6.05		1/2" SD	

Angle Retractable Fixtured Options

EB33

Spring Options	Part No.
Standard	A5313
8 lb Compression	20R201407
Output Options	Part No.
2" Extended Output	20D115901
Reaction Device	Part No.
Reaction Bar, Steel (Default)	20K100000
Base Mount Bracket	20K100500
Mounting Flange-B	20K100300
Suspension Bails	Part No.
Wire Bail	A3061
Swivel	20K200000
Standard	B3432
1/2" SD Socket Lock Pin	Part No.
Standard	20D227800
Rounded (Ball Detent)	20D227801

**Due to the welded flange, the above options are not applicable to EB33MA18F1-XX tools.*

Angle Retractable Fixtured Options

EB34, EB44

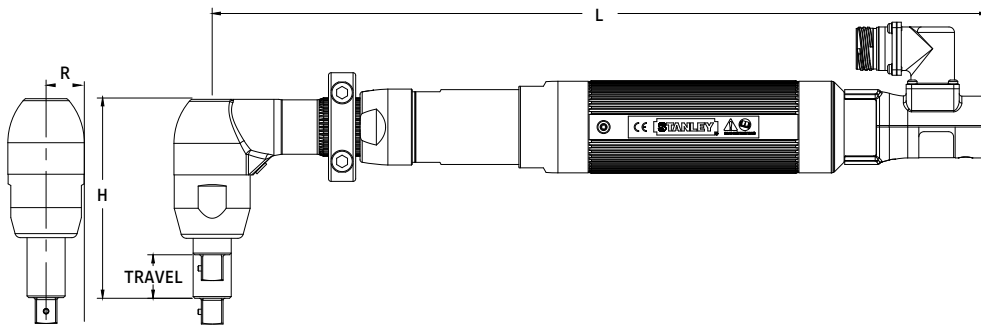

Model	Rated Speed		Max Torque		"R" Side to Center		"H" Head Height		"L" Length		Weight		Output	
	RPM	Nm	lb ft	mm	in	mm	in	mm	in	kg	lb	Retraction	Standard	
EB34MA22AF1-80	510	80	59.0	22	0.87	114	4.5	441	17.4	3.1	6.75	25 mm 1"	1/2" SD	
EB44MA22AF1-80	810	80	59.0	22	0.87	114	4.5	453	17.8	3.5	7.72			
EB34MA22AF1-115	340	115	84.8	22	0.87	114	4.5	463	18.2	3.1	6.75			
EB44MA22AF1-120	550	120	88.5	22	0.87	114	4.5	453	17.8	3.5	7.72			

Spring Options	Part No.
Standard	M4283
5.8 lb Compression	H4003
8.6 lb Compression	M4800
Output Options	Part No.
2" Extended Output	M4306
2-5/8" Extended Output	20D117700
8" Extended Output	M4466
Reaction Device	Part No.
Reaction Bar, Steel (Default)	20K100100
Base Mount Bracket	20K100500
Mounting Flange	20K100302
1/2" SD Socket Lock Pin	Part No.
Standard	20D227800
Rounded (Ball Detent)	20D227801



Sockets and Accessories
begin on page 92

Angle Retractable Fixtured Tools

24 to 400 Nm

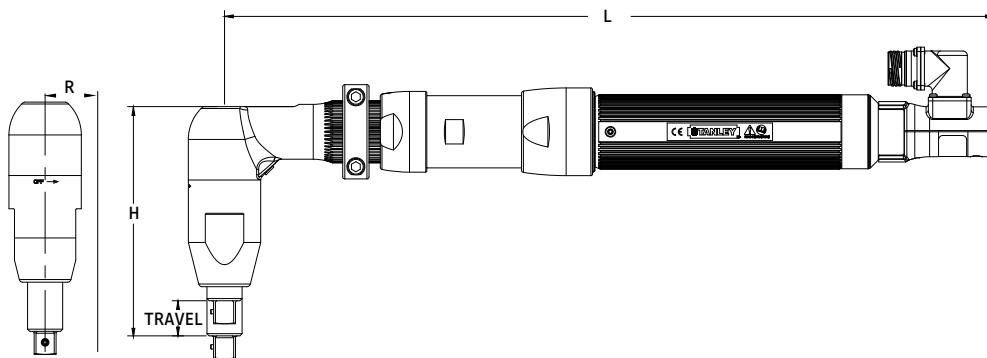

Model	Rated Speed		Max Torque		"R" Side to Center		"H" Head Height		"L" Length		Weight		Output	
	RPM	Nm	lb ft	mm	in	mm	in	mm	in	kg	lb	Retraction	Standard	
EB55MA26F1-120	825	120	88.5	26	1.02	166	6.5	557	21.9	5.2	11.4	25 mm 1"	3/4" SD	
EB55MA26F1-160	620	160	118	26	1.02	166	6.5	557	21.9	5.2	11.4			
EB45MA26F1-165	400	165	122	26	1.02	166	6.5	503	19.8	4.6	10.0			
EB45MA26F1-220	260	220	162	26	1.02	166	6.5	527	20.7	4.6	10.0			
EB55MA26F1-220	460	220	162	26	1.02	166	6.5	557	21.9	7.5	16.6			

Angle Retractable Fixtured Options

EB45, EB55

Spring Options	Part No.
Standard	20R201414
11 lb Compression	20R201417
Reaction Device	Part No.
Reaction Bar, Steel (Default)	20K100200
Reaction Bar, Steel	20K100202
Base Mount Bracket	20K100600
Mounting Flange-B	20K100700
3/4" SD Socket Lock Pin	Part No.
Standard	20D227800
Rounded (Ball Detent)	20D227802

Angle Retractable Fixtured Options

EB55

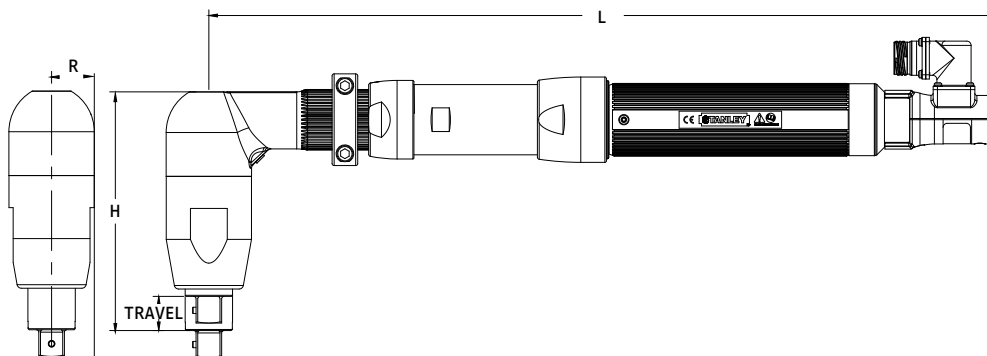

Model	Rated Speed		Max Torque		"R" Side to Center		"H" Head Height		"L" Length		Weight		Output	
	RPM	Nm	lb ft	mm	in	mm	in	mm	in	kg	lb	Retraction	Standard	
EB55MA32F1-300	340	300	221	32	1.26	178	7.0	563	22.1	7.3	16.1	25 mm 1"	3/4" SD	
EB55MA32F1-400	225	400	295	32	1.26	178	7.0	563	22.1	7.3	16.1			

Spring Options	Part No.
Standard	M4606
7.6 lb Compression	M4331
Output Options	Part No.
2.5" Extended Output	20D114800
4" Extended Output	M4740
Reaction Device	Part No.
Reaction Bar, Steel (Default)	20K100200
Reaction Bar, Steel	20K100202
Base Mount Bracket	20K100600
Mounting Flange-B	20K100700
3/4" SD Socket Lock Pin	Part No.
Standard	20D227800
Rounded (Ball Detent)	20D227802

Mounting / Reaction Options

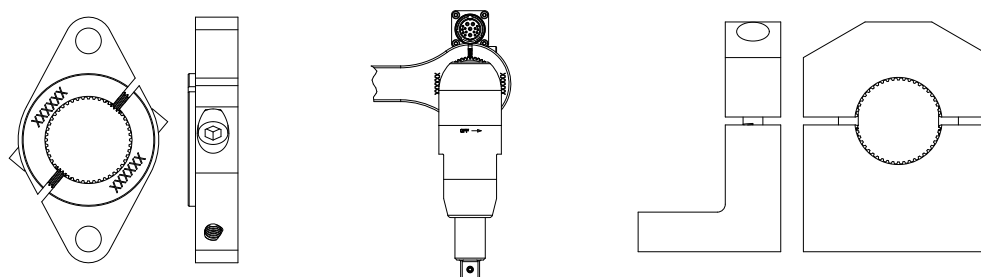

Optional Flange Mount Bracket

Standard Reaction Bar

Optional Base Mount Bracket



Sockets and Accessories begin on page 92

Angle Retractable Fixtured Tools

12 to 400 Nm

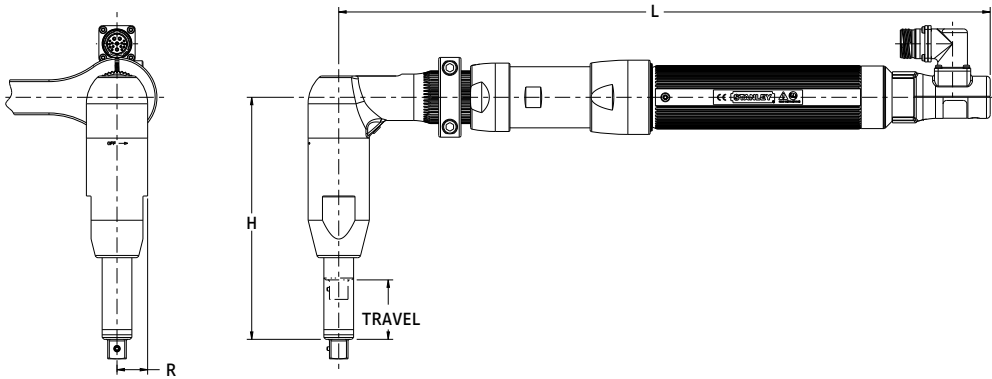

Model	Rated Speed		Max Torque		"R" Side to Center		"H" Head Height		"L" Length		Weight		Output	
	RPM	Nm	lb ft	mm	in	mm	in	mm	in	kg	lb	Retraction	Standard	
EB33MA18F2-35	1165	35	25.8	18	0.71	176.28	6.94	462.74	18.22	3.25	7.2	50.8 mm 2"	3/8" SD	
EB33MA18F2-48	880	48	35.4	18	0.71	176.28	6.94	462.74	18.22	3.25	7.2			
EB33MA19F2-60	680	60	44.2	19	0.75	193	7.6	386	15.2	3.1	6.83		1/2" SD	
EB34MA19F2-70	610	70	51.6	19	0.75	177.67	6.99	433.16	17.05	3.5	7.7		3/8" SD	
EB34MA22AF2-115	335	115	84.8	22	0.87	186.2	7.33	463	18.2	3.5	7.7		5/8" SD	
EB55MA26F2-220	460	220	162	26	1.02	225	8.9	557	21.9	5.7	12.5		3/4" SD	
EB55MA32F2-300	340	300	221	32	1.26	269	10.6	563	22.2	7.8	17.2			
EB55MA32F2-400	225	400	295	32	1.26	269	10.6	586	23	7.8	17.2			

Angle Retractable Fixtured Options

EB45, EB55

Spring Options	Part No.
Standard	20R201414
11 lb Compression	20R201417
Reaction Device	Part No.
Reaction Bar, Steel (Default)	20K100200
Reaction Bar, Steel	20K100202
Base Mount Bracket	20K100600
Mounting Flange-B	20K100700
3/4" SD Socket Lock Pin	Part No.
Standard	20D227800
Rounded (Ball Detent)	20D227802

Angle Retractable Fixtured Options

EB55

Spring Options	Part No.
Standard	M4606
7.6 lb Compression	M4331
Output Options	Part No.
2.5" Extended Output	20D114800
4" Extended Output	M4740
Reaction Device	Part No.
Reaction Bar, Steel (Default)	20K100200
Reaction Bar, Steel	20K100202
Base Mount Bracket	20K100600
Mounting Flange-B	20K100700
3/4" SD Socket Lock Pin	Part No.
Standard	20D227800
Rounded (Ball Detent)	20D227802

Mounting / Reaction Options

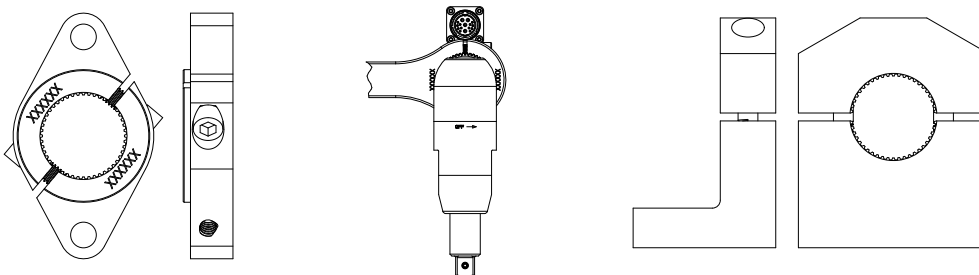

Optional Flange Mount Bracket

Standard Reaction Bar

Optional Base Mount Bracket



Sockets and Accessories
begin on page 92

Inline Fixtured Tools

5.6 to 120 Nm

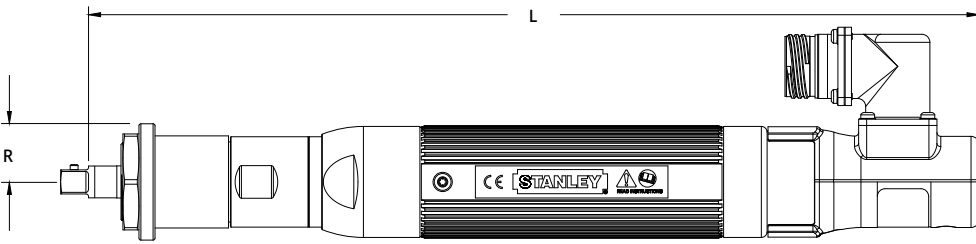

Model	Rated Speed		Max Torque		"R" Side to Center		"L" Length		Weight		Output
	RPM	Nm	lb ft	mm	in	mm	in	kg	lb	Standard	
EB33MB-28	1590	28	20.6	24	0.93	359	14.1	1.89	4.15	3/8" SD	
EB33MB-40	1120	40	29.5	24	0.93	385	15.1	1.89	4.15		

Inline Fixtured Options

EB33

Reaction Device	Part No.
Reaction Bar, Aluminum [Default]	F3698
Reaction Bar, Steel	20K100100
Base Mount Bracket	A8606
Mounting Flange-B	20K101000
Suspension Bails	Part No.
Wire Bail	A3061
Swivel	20K101400
Standard	B3432
3/8" SD Socket Lock Pin [EB33]	Part No.
Standard	20D227800
Rounded [Ball Detent]	20D227801

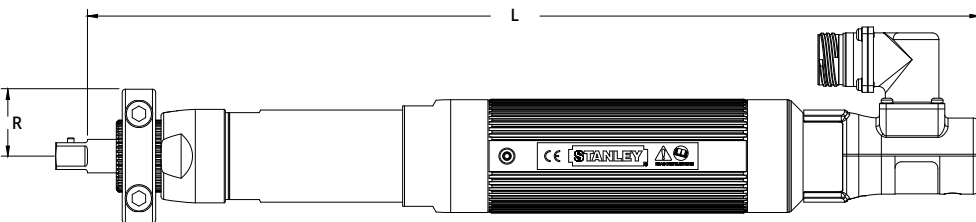

Model	Rated Speed		Max Torque		"R" Side to Center		"L" Length		Weight		Output
	RPM	Nm	lb ft	mm	in	mm	in	kg	lb	Standard	
EB34MB1-55	830	55	40.5	32	1.03	421	16.6	2.2	4.84	1/2" SD	
EB44MB1-80	895	80	59	32	1.03	421	16.6	2.7	5.94		
EB44MB1-120	557	120	88.5	32	1.03	421	16.6	2.7	5.94		

Inline Fixtured Options

EB34, EB44

Reaction Device	Part No.
Reaction Bar, Steel [Default]	20K100100
Base Mount Bracket	20K100500
Mounting Flange-B	20K100300
1/2" SD Socket Lock Pin	Part No.
Standard	20D227800
Rounded [Ball Detent]	20D227801

Mounting / Reaction Options

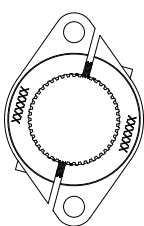

Optional Flange Mount Bracket

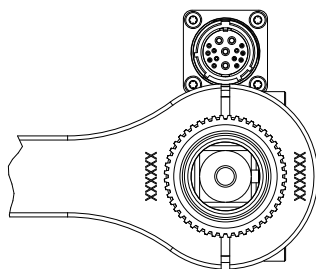

Standard Reaction Bar

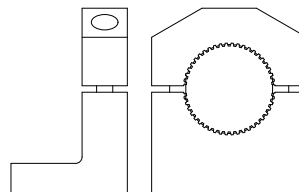

Optional Base Mount Bracket

Inline Fixtured Tools

28 to 2000 Nm

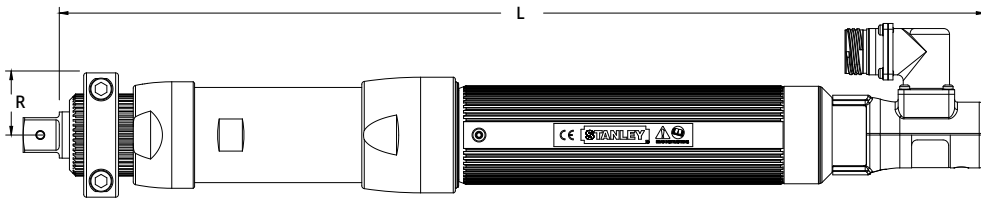

Model	Rated Speed		Max Torque		"R" Side to Center		"L" Length		Weight		Output
	RPM	Nm	lb ft	mm	in	mm	in	kg	lb	Standard	
EB45MB2-140	465	140	103	34	1.34	475	18.7	3.6	7.92	3/4" SD	
EB55MB2-170	640	170	125	34	1.34	475	18.7	4.3	9.46	3/4" SD	
EB45MB2-190	355	190	140	34	1.34	475	18.7	4.3	9.46	3/4" SD	
EB55MB2-250	400	250	184	34	1.34	475	18.7	5.3	11.7	3/4" SD	

Inline Fixtured Options

EB45, EB55 (MB2 Models)

Reaction Device	Part No.
Reaction Bar, Steel (Default)	20K100200
Base Mount Bracket	20K100600
Mounting Flange-B	20K100700
3/4" SD Socket Lock Pin	Part No.
Standard	20D227800
Rounded (Ball Detent)	20D227802

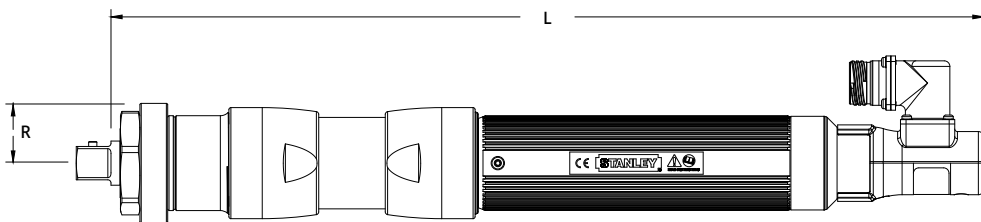

Model	Rated Speed		Max Torque		"R" Side to Center		"L" Length		Weight		Output
	RPM	Nm	lb ft	mm	in	mm	in	kg	lb	Standard	
EB55MB3-320	310	320	236	35	1.38	517	20.4	5.5	12.1	3/4" SD	

Inline Fixtured Options

EB55MB3 Model

Reaction Device	Part No.
Reaction Bar, Steel (Default)	B4487
Base Mount Bracket	H1140
Mounting Flange-B	M4329
3/4" SD Socket Lock Pin	Part No.
Standard	20D227800
Rounded (Ball Detent)	20D227802

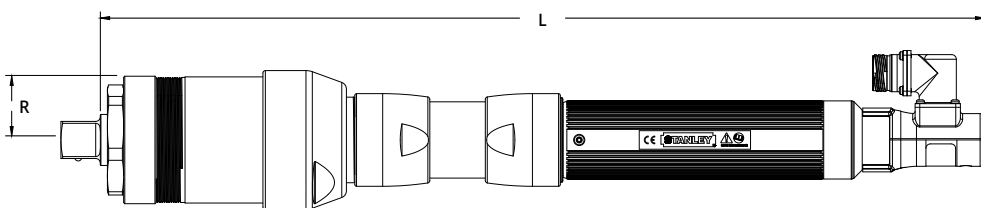

Model	Rated Speed		Max Torque		"R" Side to Center		"L" Length		Weight		Output
	RPM	Nm	lb ft	mm	in	mm	in	kg	lb	Standard	
EB55MB4-460	220	460	339	44	1.7	564	22.2	7.5	16.8	1" SD	
EB55MB4-620	165	620	457	44	1.7	564	22.2	7.5	16.8	1" SD	
EB55MB5-800	125	800	590	48	1.9	575	22.6	9	19.8	1" SD	
EB55MB5-1100	80	1100	811	48	1.9	598	23.6	10.1	22.3	1" SD	
EB55MB5-1500	60	1500	1106	48	1.9	625	24.6	10.1	22.3	1" SD	
EB55MB5-2000	50	2000	1475	48	1.9	625	24.6	10.1	22.3	1" SD	

Inline Fixtured Options

EB55MB4 & 5 Models

Reaction Device	Part No.
Reaction Bar, Steel (Default)	F4192
Base Mount Bracket	F4201
Mounting Flange-B	20K101100
1" SD Socket Lock Pin	Part No.
Standard	20D227800
Rounded (Ball Detent)	20D227802

Inline Retractable Fixtured Tools

5.6 to 250 Nm

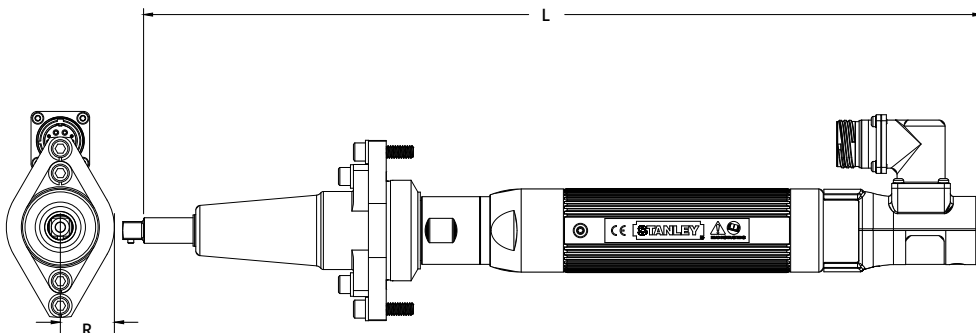

Model	Rated Speed		Max Torque		"R" Side to Center		"L" Length		Weight		Output	
	RPM	Nm	lb ft	mm	in	mm	in	kg	lb	Retraction	Standard	
EB33MBF1-28	1590	28	20.6	28	1.13	443	17.4	2.56	5.63	25 mm 1"	9.5 mm 3/8" SD	
EB33MBF1-40	1120	40	29.5	28	1.13	443	17.4	2.56	5.63			

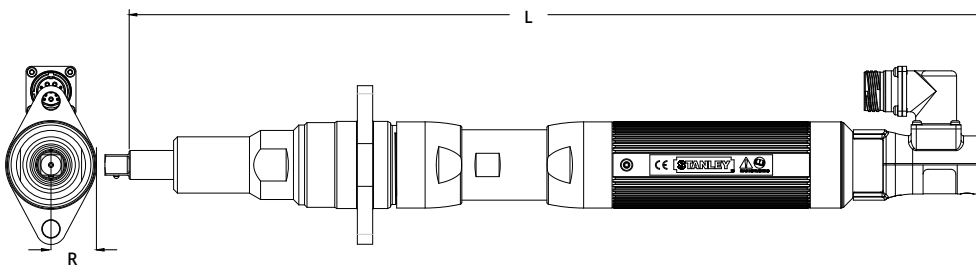

Model	Rated Speed		Max Torque		"R" Side to Center		"L" Length		Weight		Output	
	RPM	Nm	lb ft	mm	in	mm	in	kg	lb	Retraction	Standard	
EB34MB1F1-55	830	55	40.5	28	1.11	499	19.6	3.3	7.24	25 mm 1"	13 mm 1/2" SD	
EB34MB1F1-75	545	75	55.3	28	1.11	520.7	20.5	3.25	7.2			
EB44MB1F1-80	895	80	59.0	28	1.11	511	20.1	3.8	8.34			
EB44MB1F1-120	560	120	88.5	28	1.11	533	21.0	3.8	8.34			

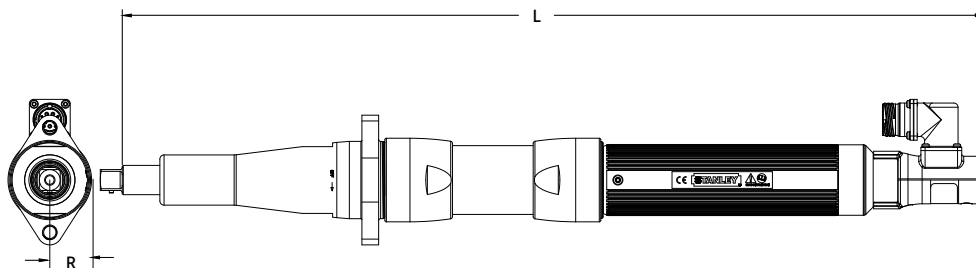

Model	Rated Speed		Max Torque		"R" Side to Center		"L" Length		Weight		Output	
	RPM	Nm	lb ft	mm	in	mm	in	kg	lb	Retraction	Standard	
EB45MB2F1-140	465	140	103	32	1.25	600	23.6	3.6	7.92	25 mm 1"	16 mm 5/8" SD	
EB55MB2F1-170	640	170	125	32	1.25	631	24.8	6.5	14.4			
EB45MB2F1-190	355	190	140	32	1.25	600	23.6	3.6	7.92			
EB55MB2F1-250	400	250	184	32	1.25	654	25.7	6.8	15.0			

Inline Retractable Fixtured Options

3/8" Output

Output Options	Part No.
Standard	M3050
24 Threaded	M3118
24 Threaded, 3/4" Long	M3227
1-5/32" Extension	S3362
1.478" Extension	M3243
2" Extension	M3090
2-3/8" Extension	S3363
3" Extension	M3229
4" Extension	M3223
4-1/16" Extension	S3486
6" Extension	M3224
7-3/8" Extension	S3626
8" Extension	M3216
8" Extension Assembly	20S104600
Spring Options	Part No.
Standard	M4096
Heavy Duty Spring	M3184
Extra Heavy Duty Spring	20R201428

Inline Retractable Fixtured Options

1/2" Output

Output Options	Part No.
Standard	20D101600
2" Extension	20D101610
3" Extension	20D101603
4" Extension	20D101608
5" Extension	20D101604
6" Extension	20D101606
7-5/16" Extension	20D101605
8" Extension	20D101609
11" Extension	20D101607
Spring Options	Part No.
Standard	B4093
Heavy Duty Spring	20R201401

Inline Retractable Fixtured Options

5/8" Output

Output Options	Part No.
Standard	20D102901
2" Extension	20D102912
6" Extension	20D102913
Spring Options	Part No.
Standard	20R201407
Heavy Duty Spring	20R201408

Inline Retractable Fixtured Tools

64 to 2000 Nm

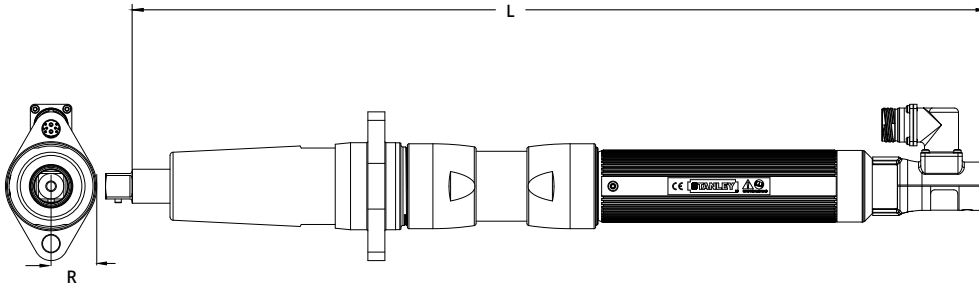

Model	Rated Speed		Max Torque		"R" Side to Center		"L" Length		Weight		Output	
	RPM	Nm	lb ft	mm	in	mm	in	kg	lb	Retraction	Standard	
EB55MB3F1-320	310	320	236	34	1.34	636	25	6.7	14.74	25mm 1"	19mm 3/4" SD	

Inline Retractable Fixtured Options

3/4" Output

Output Options	Part No.
Standard	20D102101
5" Extension	20D102106
Spring Options	Part No.
Standard	20R201403
Heavy Duty Spring	20R201404
Reaction Components	Part No.
Mounting Flange - MB3F	20D205600

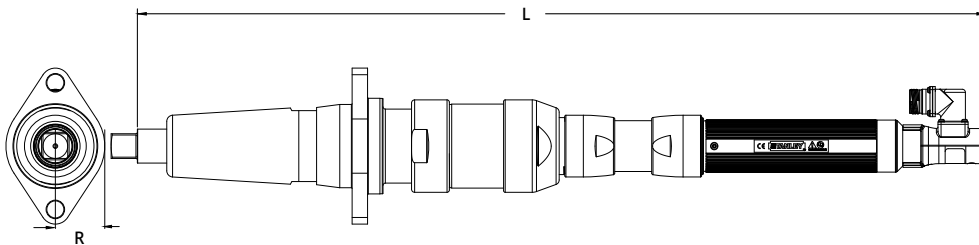

Model	Rated Speed		Max Torque		"R" Side to Center		"L" Length		Weight		Output	
	RPM	Nm	lb ft	mm	in	mm	in	kg	lb	Retraction	Standard	
EB55MB4F1-460	220	460	339	44	1.7	803	31.6	17.2	37.84	25mm 1"	25mm 1" SD	
EB55MB4F1-620	165	620	457	44	1.7	803	31.6	17.2	37.84			
EB55MB5F1-800	125	800	590	50	2	840	33.0	18.3	40.26			
EB55MB5F1-1100	80	1100	811	50	2	863	34.0	18.3	40.26			
EB55MB5F1-1500	60	1500	1106	50	2	870	34.3	19.2	42.24			
EB55MB5F1-2000	50	2000	1475	50	2	870	34.3	19.2	42.24			

Inline Retractable Fixtured Options

1" Output

Output Options	Part No.
Standard	20D208800
2" Extension	20D208803
4" Extension	20D208802
3/4" SD (MB4F1 ONLY)	20D121100
Reaction Components	Part No.
Mounting Flange - MB4F	20D208500
Mounting Flange - MB5F	20D209500
Spring Options	Part No.
Standard	20R201411
Heavy Duty Spring	20R201442

Inline Retractable Fixtured Tools

5.6 to 190 Nm

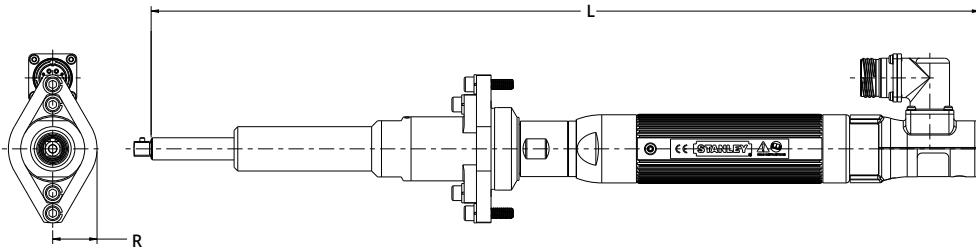

Model	Rated Speed		Max Torque		"R" Side to Center		"L" Length		Weight		Output	
	RPM	Nm	lb ft	mm	in	mm	in	kg	lb	Retraction	Standard	
EB33MBF2-28	1590	28	20.6	28	1.13	443	17.4	2.56	5.63	51mm	9.5mm	
EB33MBF2-40	1120	40	29.5	28	1.13	443	17.4	2.56	5.63	2"	3/8" SD	

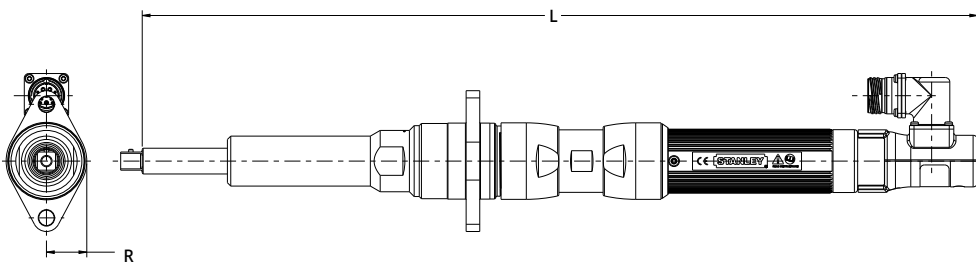

Model	Rated Speed		Max Torque		"R" Side to Center		"L" Length		Weight		Output	
	RPM	Nm	lb ft	mm	in	mm	in	kg	lb	Retraction	Standard	
EB44MB1F2-55	830	55	40.5	28	1.11	499	19.6	3.3	7.24	51mm 2"	13mm 1/2" SD	
EB34MB1F2-75	545	75	55.3	28	1.11	605.8	23.85	3.3	7.24			
EB44MB1F2-80	895	80	59.0	28	1.11	511	20.1	3.8	8.34			
EB44MB1F2-120	560	120	88.5	28	1.11	533	21.0	3.8	8.34			

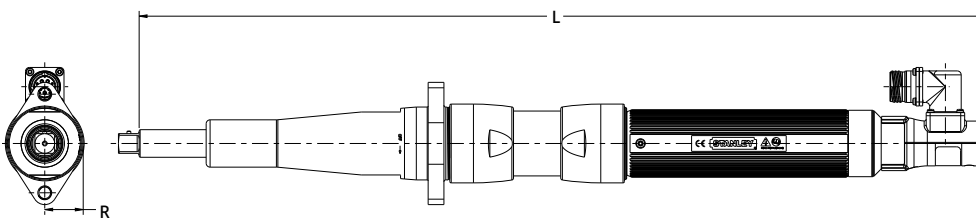

Model	Rated Speed		Max Torque		"R" Side to Center		"L" Length		Weight		Output	
	RPM	Nm	lb ft	mm	in	mm	in	kg	lb	Retraction	Standard	
EB45MB2F2-140	465	140	103	32	1.25	651	25.6	3.6	7.92	51mm 2"	16mm 5/8" SD	
EB55MB2F2-170	640	170	125	32	1.25	681	26.8	6.5	14.4			
EB45MB2F2-190	355	190	140	32	1.25	651	25.6	3.6	7.92			

Inline Retractable Fixtured Options

3/8" Output

Output Options	Part No.
Standard	M3050
24 Threaded	M3118
24 Threaded, 3/4" Long	M3227
1-5/32" Extension	S3362
1.478" Extension	M3243
2" Extension	M3090
2-3/8" Extension	S3363
3" Extension	M3229
4" Extension	M3223
4-1/16" Extension	S3486
6" Extension	M3224
7-3/8" Extension	S3626
8" Extension	M3216
8" Extension Assembly	20S104600
Spring Options	Part No.
Standard	M4096
Heavy Duty Spring	M3184
Extra Heavy Duty Spring	20R201428

Inline Retractable Fixtured Options

1/2" Output

Output Options	Part No.
Standard	20D101600
2" Extension	20D101610
3" Extension	20D101603
4" Extension	20D101608
5" Extension	20D101604
6" Extension	20D101606
7-5/16" Extension	20D101605
8" Extension	20D101609
11" Extension	20D101607
Spring Options	Part No.
Standard	B4093
Heavy Duty Spring	20R201401

Inline Retractable Fixtured Options

5/8" Output

Output Options	Part No.
Standard	20D102901
2" Extension	20D102912
6" Extension	20D102913
Spring Options	Part No.
Standard	20R201407
Heavy Duty Spring	20R201408

Inline Retractable Fixtured Tools

64 to 2000 Nm

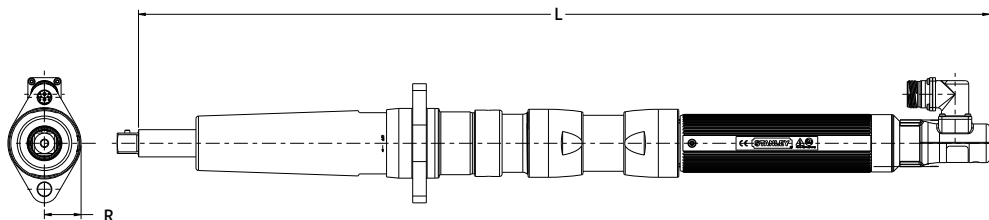

Model	Rated Speed		Max Torque		"R" Side to Center		"L" Length		Weight		Output	
	RPM	Nm	lb ft	mm	in	mm	in	kg	lb	Retraction	Standard	
EB55MB3F2-320	310	320	236	34	1.34	636	25	6.7	14.74	51mm 2"	19mm 3/4" SD	

Inline Retractable Fixtured Options

3/8" Output

Output Options	Part No.
Standard	20D102101
5" Extension	20D102106
Spring Options	Part No.
Standard	20R201403
Heavy Duty Spring	20R201404
Reaction Components	Part No.
Mounting Flange -MB3F	20D205600

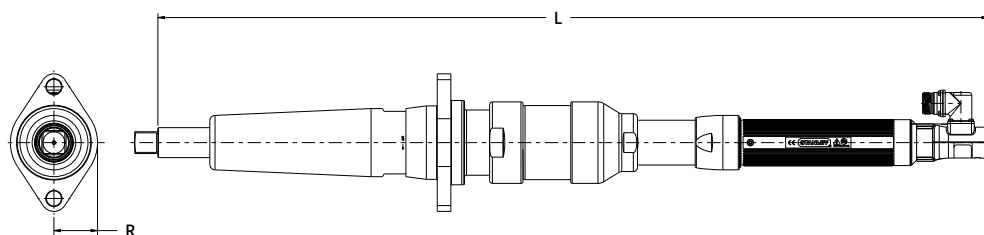

Model	Rated Speed		Max Torque		"R" Side to Center		"L" Length		Weight		Output	
	RPM	Nm	lb ft	mm	in	mm	in	kg	lb	Retraction	Standard	
EB55MB4F2-460	220	460	339	44	1.7	803	31.6	17.2	37.84	51mm 2"	25mm 1" SD	
EB55MB4F2-620	165	620	457	44	1.7	803	31.6	17.2	37.84			
EB55MB5F2-800	125	800	590	50	2	840	33.0	18.3	40.26			
EB55MB5F2-1100	80	1100	811	50	2	863	34.0	18.3	40.26			
EB55MB5F2-1500	60	1500	1106	50	2	870	34.3	19.2	42.24			
EB55MB5F2-2000	50	2000	1475	50	2	870	34.3	19.2	42.24			

Inline Retractable Fixtured Options

1" Output

Output Options	Part No.
Standard	20D208800
2" Extension	20D208803
4" Extension	20D208802
3/4" SD (MB4F1 ONLY)	20D121100
Reaction Components	Part No.
Mounting Flange -MB4F	20D208500
Mounting Flange -MB5F	20D209500

Offset Retractable Fixtured Tools (3/4", 1")

5 to 225 Nm

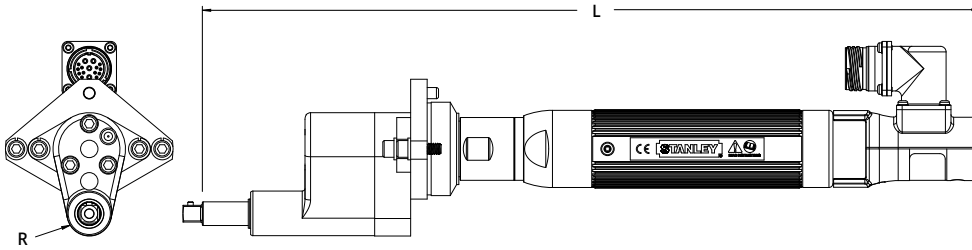

Model	Rated Speed		Torque		"R" Side to Center		"L" Length		Weight		Output	
	RPM	Nm	lb ft	mm	in	mm	in	kg	lb	Retraction	Standard	
EB33MDF1-25	1590	25	18.4	13	0.51	443	17.5	3.1	6.78	19mm [3/4"]	3/8" SD	
EB33MDF1-36	1120	36	26.6	13	0.51	443	17.5	3.1	6.82			

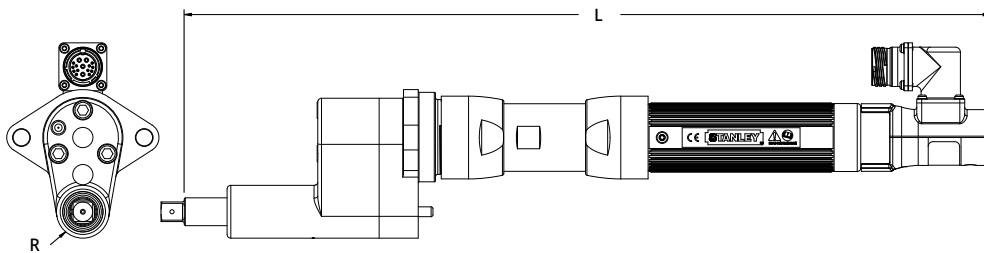

Model	Rated Speed		Torque		"R" Side to Center		"L" Length		Weight		Output	
	RPM	Nm	lb ft	mm	in	mm	in	kg	lb	Retraction	Standard	
EB44MD1F1-70	895	70	51.6	17	0.67	511	20.2	4.8	10.56	25mm [1"]	1/2" SD	
EB44MD1F1-108	560	108	79.7	17	0.67	533	21	4.8	10.56			
EB34MD1F1-48	830	48	35.4	17	0.67	499	19.7	4.4	9.68			

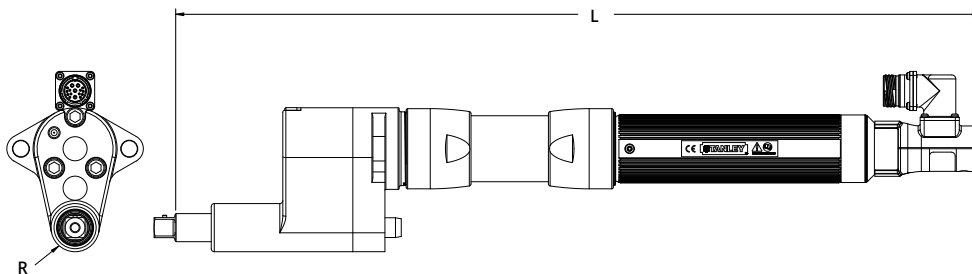

Model	Rated Speed		Torque		"R" Side to Center		"L" Length		Weight		Output	
	RPM	Nm	lb ft	mm	in	mm	in	kg	lb	Retraction	Standard	
EB45MD2F1-125	465	125	92.2	19	0.75	584	23	10.5	23.2	25mm [1"]	5/8" SD	
EB55MD2F1-150	640	150	110.7	19	0.75	614	24.2	10.5	23.2			
EB45MD2F1-170	355	170	125.4	19	0.75	584	23	10.5	23.2			
EB55MD2F1-225	400	225	166	19	0.75	637	25.1	10.5	23.2			

Retractable Options

EB33

Spring Options	Part No.
Standard	M3062
Heavy Duty	M3183
Output Options	Part No.
3/4" Extended Output	M3227
1-5/32" Extended Output	S3362
1.478" Extended Output	M3243
2" Extended Output	M3090
2-3/8" Extended Output	S3363
3" Extended Output	M3239
4" Extended Output	M3223
4-1/16" Extended Output	S3486
6" Extended Output	M3224
7-3/8" Extended Output	S3626
8" Extended Output	M3216
8" Extended Output, Thin	20S104600
24 Threaded Output	M3118
1/2" Square Drive Lock Pin	Part No.
Standard	20D227800
Rounded [Ball Detent]	20D227801

Retractable Options

EB34, EB44

Spring Options	Part No.
Standard	B4093
Heavy Duty	20R201401
Output Options	Part No.
2" Extended Output	20D101610
3" Extended Output	20D101603
4" Extended Output	20D101608
5" Extended Output	20D101604
6" Extended Output	20D101606
7-5/16" Extended Output	20D101605
8" Extended Output	20D101609
11" Extended Output	20D101607
1/2" SD Socket Lock Pin	Part No.
Standard	20D227800
Rounded [Ball Detent]	20D227801

Retractable Options

EB45, EB55

Retraction Spring	Part No.
Standard	20R201407
Heavy Duty	20R201408
Output Options	Part No.
2" Extended Output	20D102912
6" Extended Output	20D102913
3/4" SD Socket Lock Pin	Part No.
Standard	20D227800
Rounded [Ball Detent]	20D227802

Offset Retractable Fixtured Tools (2")

5 to 225 Nm

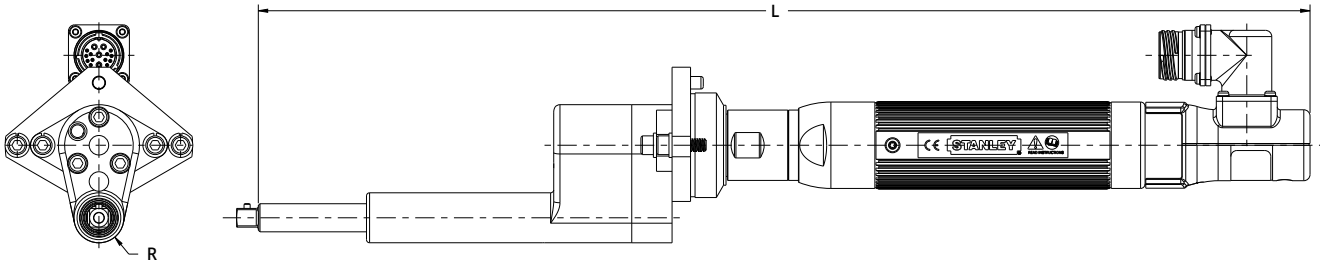

Model	Rated Speed		Torque		"R" Side to Center		"L" Length		Weight		Output	
	RPM		Nm	lb ft	mm	in	mm	in	kg	lb	Retraction	Standard
EB33MDF2-25	1590		25	18.4	13	0.51	535	21.1	3.2	7.1	51mm (2")	3/8" SD

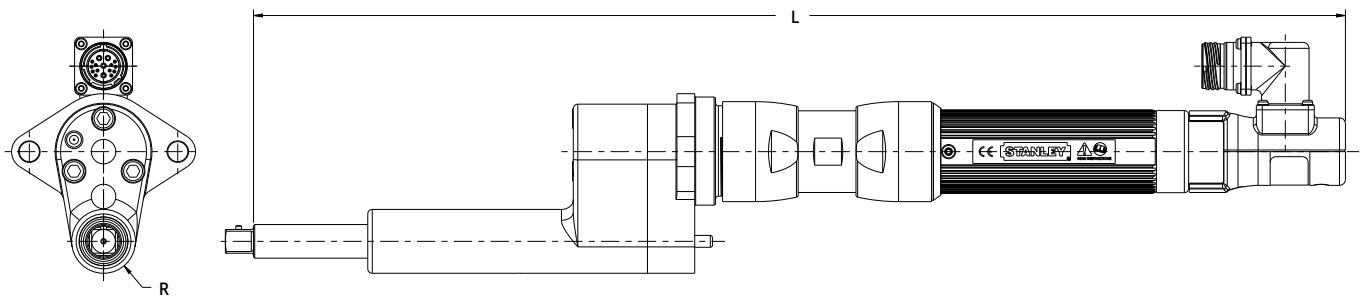

Model	Rated Speed		Torque		"R" Side to Center		"L" Length		Weight		Output	
	RPM		Nm	lb ft	mm	in	mm	in	kg	lb	Retraction	Standard
EB34MD1F2-48	830		48	35.4	17	0.67	599	23.6	4.8	10.56	51mm (2")	1/2" SD

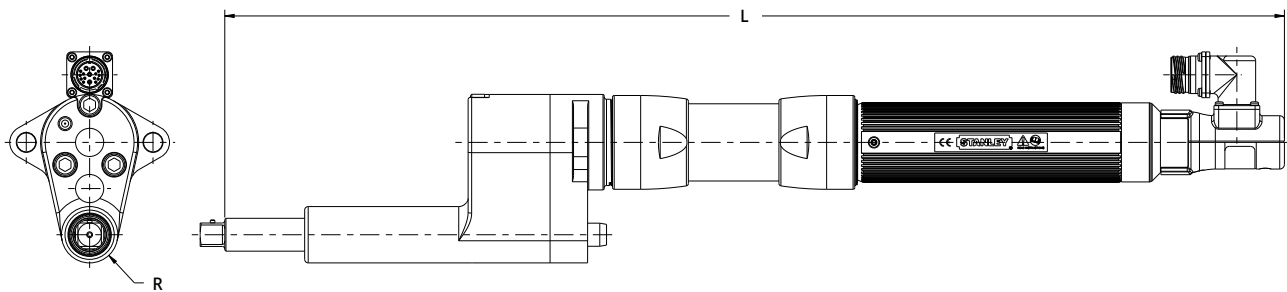

Model	Rated Speed		Torque		"R" Side to Center		"L" Length		Weight		Output	
	RPM		Nm	lb ft	mm	in	mm	in	kg	lb	Retraction	Standard
EB45MD2F2-125	465		125	92.2	19	0.75	663	26.1	10.9	24.0	51mm (2")	5/8" SD
EB45MD2F2-170	355		170	125.4	19	0.75	663	26.1	10.9	24.0		
EB55MD2F2-225	400		225	166	19	0.75	717	28.2	10.9	24.0		

Hold and Drive Fixtured Tools – 1" Output

22 to 220 Nm

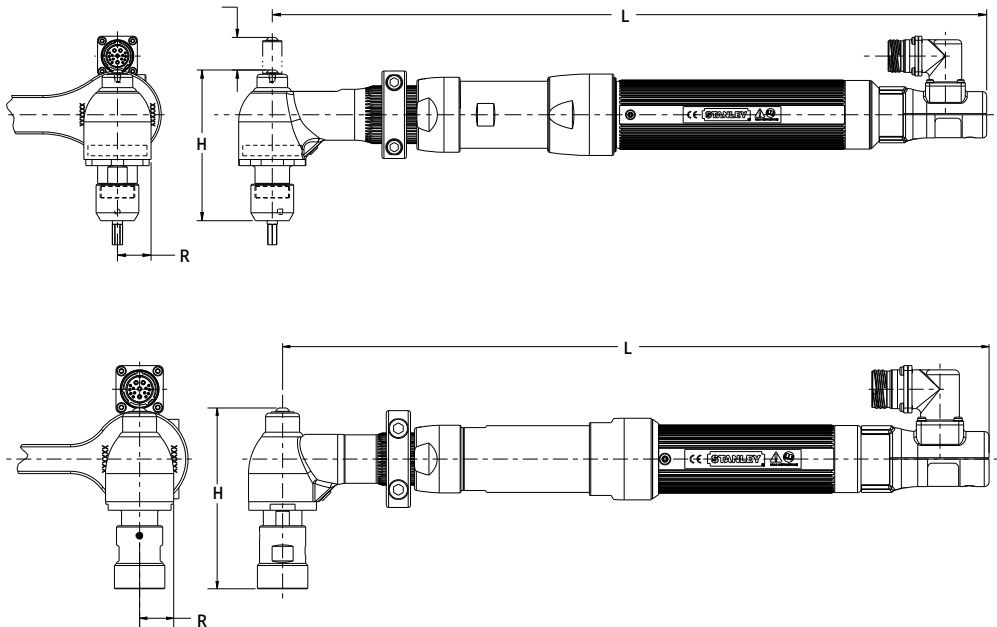

Model	Rated Speed		Torque		"R" Side to Center		"H" Head Height		"L" Length		Weight		Travel
	RPM	Nm	lb ft	mm	in	mm	in	mm	in	kg	lb	Standard	
EB34MH22AV1-110	335	110	81.1	22	0.87	118.4	4.7	543	21.4	3.7	8.2	1"	
EB45MH26V1-220	260	220	162.3	26	1.02	117.5	4.6	527	20.8	6.0	13.2		
EB55MH26V1-220	460	220	162.3	26	1.02	117.5	4.6	557	21.9	6.7	14.8		

See pages 106-117 for the Hold and Drive Configuration Guide

1" H&D Lever Tool Options

H22 Output	Part No.
Socket Options	-N4617
1" Travel Tang Holder Output	20D103211
1" Travel Bit Holder Output	20D103212
H22 Tang Holder	Part No.
Female Tang Holder Options	-F4287
H22 Bit Holder	Part No.
Bit Holder Options	-F4288
H22 Reaction Bar	Part No.
Reaction Bar Assembly [Default]	20K100000
Mounting Flange Assembly	20K100300
Base Mount Bracket Assembly	20K100500
H26 Output	Part No.
Socket Options	-F4285
1" Travel Tang Holder Output	20D103601
1" Travel Bit Holder Output	20D103602
H26 Tang Holder	Part No.
Female Tang Holder Options	-H4948
H26 Bit Holder	Part No.
Bit Holder Options	-H4947
H26 Reaction Bar	Part No.
Reaction Bar Assembly	20K100200
Mounting Flange Assembly	20K100700
Base Mount Bracket Assembly	20K100600
Reaction Bar Assembly, HD	20K100202
Handle Options	Part No.
EB3/4/5 Forward Facing Lever	20H100107

Mounting / Reaction Options

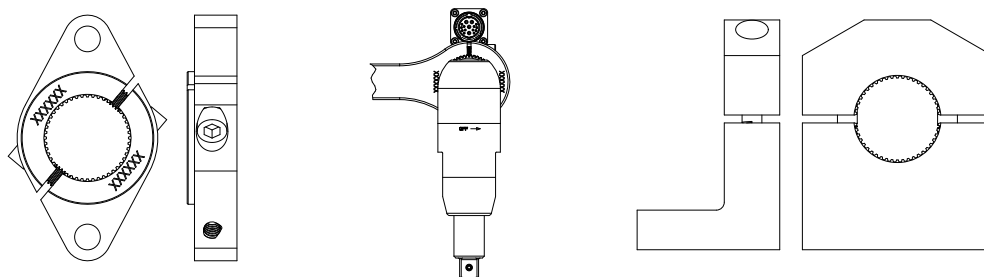

Optional Flange Mount Bracket

Standard Reaction Bar

Optional Base Mount Bracket



Sockets and Accessories
begin on page 92

Tool Cable Options: EB-Series*

STEP 1

Select a tool whip for the tool model

STEP 2

Select an extension for the selected whip number

Fits EB12-EB33
non-fixtured
tools

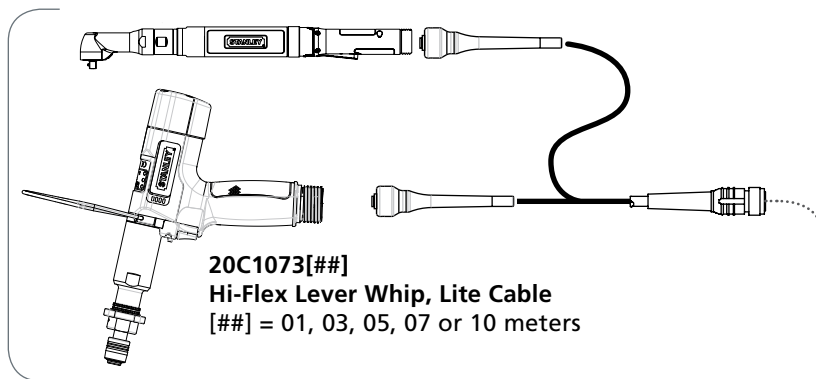

20C1073[##]
Hi-Flex Lever Whip, Lite Cable
[##] = 01, 03, 05, 07 or 10 meters

Fits EB12-EB55
non-fixtured
tools

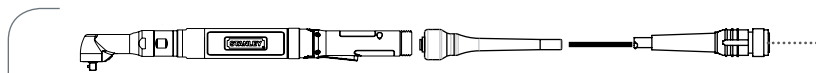

20C1076[##]
Hi-Flex Lever Whip, Heavy Duty Cable
[##] = 01, 03, 05, 07 or 10 meters

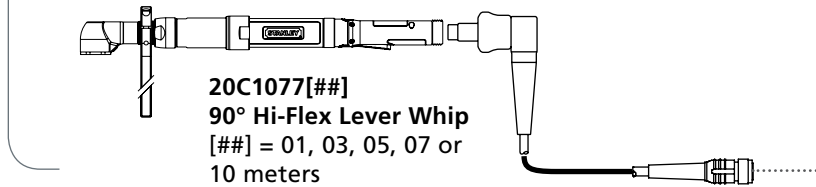

20C1077[##]
90° Hi-Flex Lever Whip
[##] = 01, 03, 05, 07 or 10 meters

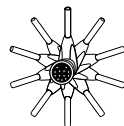

90° Hi-Flex Lever Whip Adjusts to 10 Positions @ 36°

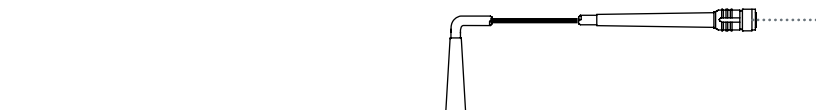

20C1094[##] Hi-Flex 90° Whip
[##] = 01, 03, 05, 07 or 10 meters

Fits
EB332-EB55
all fixtured
tools

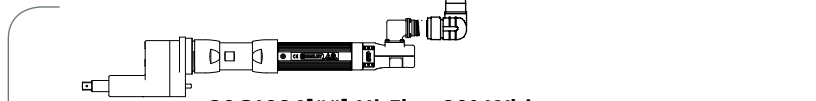

20C1093[##] Hi-Flex Whip
[##] = 01, 03, 05, 07 or 10 meters

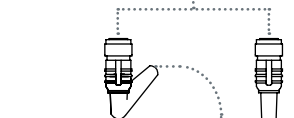

20C1078[##]
90° Jamnut Extension
[##] = 01, 05, 10, 20 or 40 meters

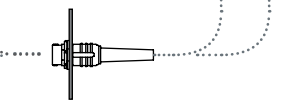

20C1075[##]
Jamnut Extension
[##] = 05, 10, 20 or 40 meters

NOTES:

Jamnut cables have connectors that can be fixed to bulkheads.

All Hi-Flex cables have an 8cm (3in) minimum bend radius.

*Fits all EB-Series Lever Tools (and older EA and EC-Series Tools)

Cable End	Cable	Lite / Heavy Duty	Base Part #	Cable Length					EB12-EB33	EB34-EB55
				01	03	05	07	10		
Straight	Hi-Flex Whip	Lite	20C1073###	01	03	05	07	10	EB12-EB33 All non-Fixtured tools	X
Straight	Hi-Flex Whip	Heavy Duty	20C1076###	01	03	05	07	10	EB12-EB33 All non-Fixtured tools	EB34-EB55 All non-Fixtured tools
90 Degree	Hi-Flex Whip	Heavy Duty	20C1077###	01	03	05	07	10	EB12-EB33 All non-Fixtured tools	EB34-EB55 All non-Fixtured tools
Straight	Hi-Flex Whip	Heavy Duty	20C1094###	01	03	05	07	10	EB33-EB55 All Fixtured Style tools	
90 Degree	Hi-Flex Whip	Heavy Duty	20C1093###	01	03	05	07	10	EB33-EB55 All Fixtured Style tools	

Option 1:

Example: Purchase Replacement Cables 20C107305 & 20C107520 to Transition to EB-Series Tools (This option requires all cables between the tool and the cable to be replaced)

— OR —

Option 2: 40% Less Expensive

Example: Purchase Replacement Cable 20C107305 and Adaptor 20C109900, use the existing festooned E-Series Extension Cable 20C1002##. (This option requires ONLY the cable attached to the extension cable to be replaced)

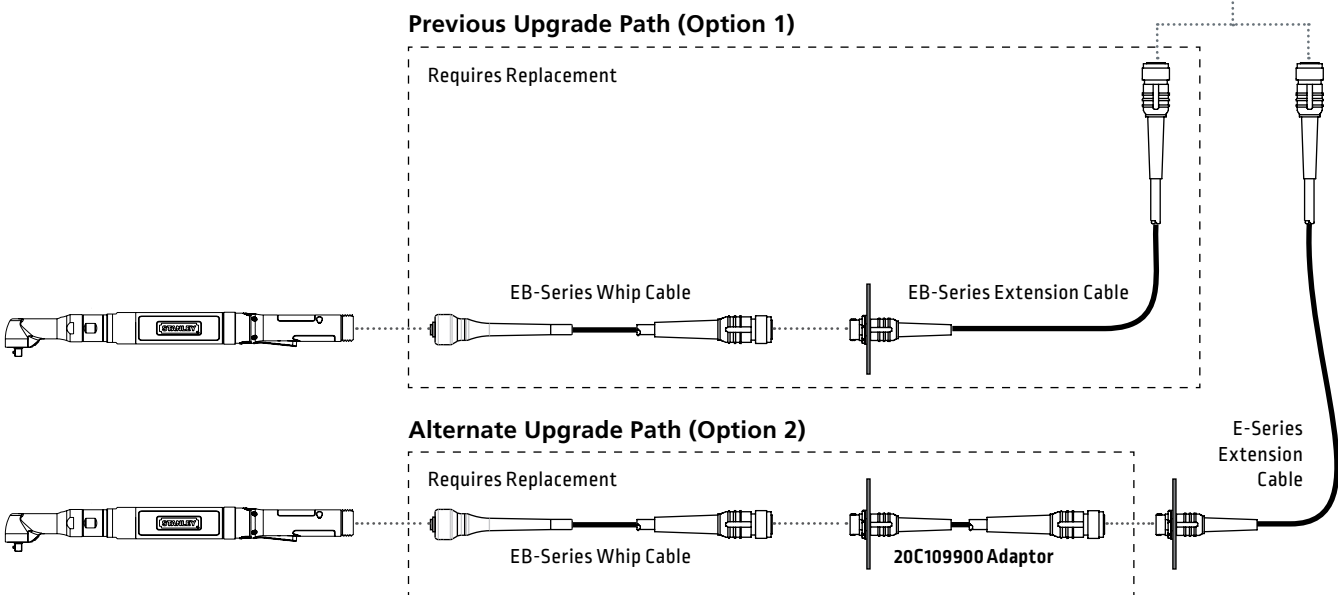

Tool Cable Options: E-Series

Fits E12
non fixtured
lever tools



**20C1046[##] Hi-Flex E1
Lever Whip [##] = 01, 03,
05, 07 or 10 meters**

Fits E02 &
E12 Bottom
Exit Pistol
Tools

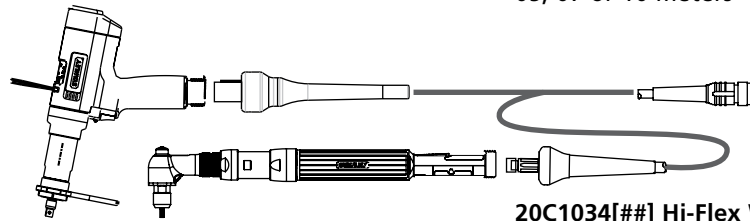

**20C1034[##] Hi-Flex Whip,
E02/34 Pistol or E23/34
Lever, [##] = 01, 03, 05, 07
or 10 meters**

Fits E23-E35
non fixtured
tools

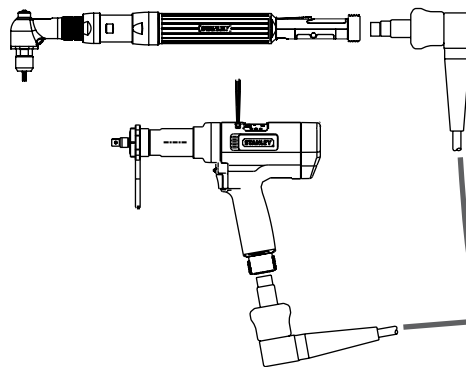

**20C1001[##] 90° Hi-Flex
E2 Lever Whip
[##] = 01, 03, 05, 07
or 10 meters**

**E12 does not apply*

Fits E02 &
E12 Bottom
Exit Pistol
tools

Fits E23-E55
non fixtured
tools

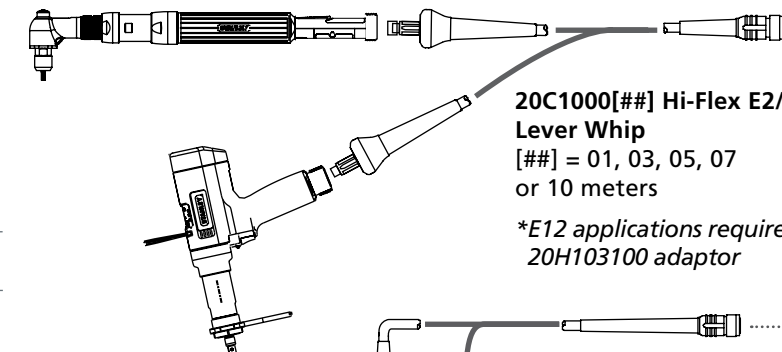

**20C1000[##] Hi-Flex E2/5
Lever Whip
[##] = 01, 03, 05, 07
or 10 meters**

**E12 applications require a
20H103100 adaptor*

**20C1011[##]
90° Jamnut
Extension
[##] = 05, 10 or
20 meters**

**20C1002[##]
Jamnut Extension
[##] = 05, 10
or 20 meters**

**20C1004[##] Hi-Flex 90°
Whip [##] = 01, 03, 05,
07 or 10 meters**

*Tool adjusts to 10 positions
@ 36°*

**20C1003[##] Hi-Flex Whip
[##] = 01, 03, 05, 07
or 10 meters**

Fits E02 & E12
Top Exit
Pistol tools

Fits E23-E55
fixtured tools

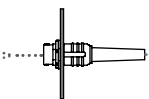
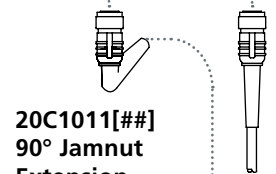
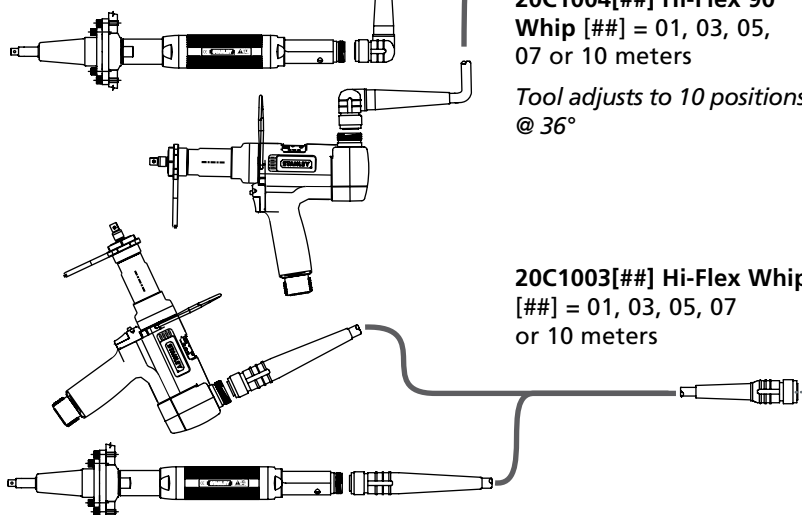

NOTES:

*Jamnut cables have
connectors that
can be fixed to
bulkheads.*

*All Hi-Flex cables
have an 8cm (3in)
minimum bend
radius.*

*Please limit the total
length of E tool
cabling between a
controller and an E
tool to 30 meters.*

Cable End	Cable	Lite / Heavy Duty	Base Part #	Cable Length					E02	E12	E23-E35	E43-E55
				01	03	05	07	10				
Straight	Hi-Flex Whip	Lite	20C1046###	01	03	05	07	10	X	E12 All Non-Fixtured Lever Tools	X	X
Straight	Hi-Flex Whip	Lite	20C1034###	01	03	05	07	10	E02 Bottom Exit Pistol Only	E12 Bottom Exit Pistol Only	E23-E35 All non-Fixtured tools	X
90 Degree	Hi-Flex Whip	Heavy Duty	20C1001###	01	03	05	07	10	E02 Bottom Exit Pistol Only	E12 Bottom Exit Pistol Only	E23-E35 All non-Fixtured tools	E43-E55 All non-Fixtured tools
Straight	Hi-Flex Whip	Heavy Duty	20C1000###	01	03	05	07	10	E02 Bottom Exit Pistol Only	E12 Bottom Exit Pistol Only	E23-E35 All non-Fixtured tools	E43-E55 All non-Fixtured tools
90 Degree	Hi-Flex Whip	Heavy Duty	20C1004###	01	03	05	07	10	E02 Top Exit Pistol Only	E12 Top Exit Pistol Only	E23-E35 All fixtured style tools	E43-E55 All fixtured style tools
Straight	Hi-Flex Whip	Heavy Duty	20C1003###	01	03	05	07	10	E02 Top Exit Pistol Only	E12 Top Exit Pistol Only	E23-E35 All fixtured style tools	E43-E55 All fixtured style tools

Please limit the total length of E tool cabling between a controller and an E tool to 30 meters.

Option 1:

Example: Purchase Replacement Cables 20C107305 & 20C107520 to Transition to EB-Series Tools (This option requires all cables between the tool and the cable to be replaced)

— OR —

Option 2: 40% Less Expensive

Example: Purchase Replacement Cable 20C107305 and Adaptor 20C109900, use the existing festooned E-Series Extension Cable 20C1002###. (This option requires ONLY the cable attached to the extension cable to be replaced)

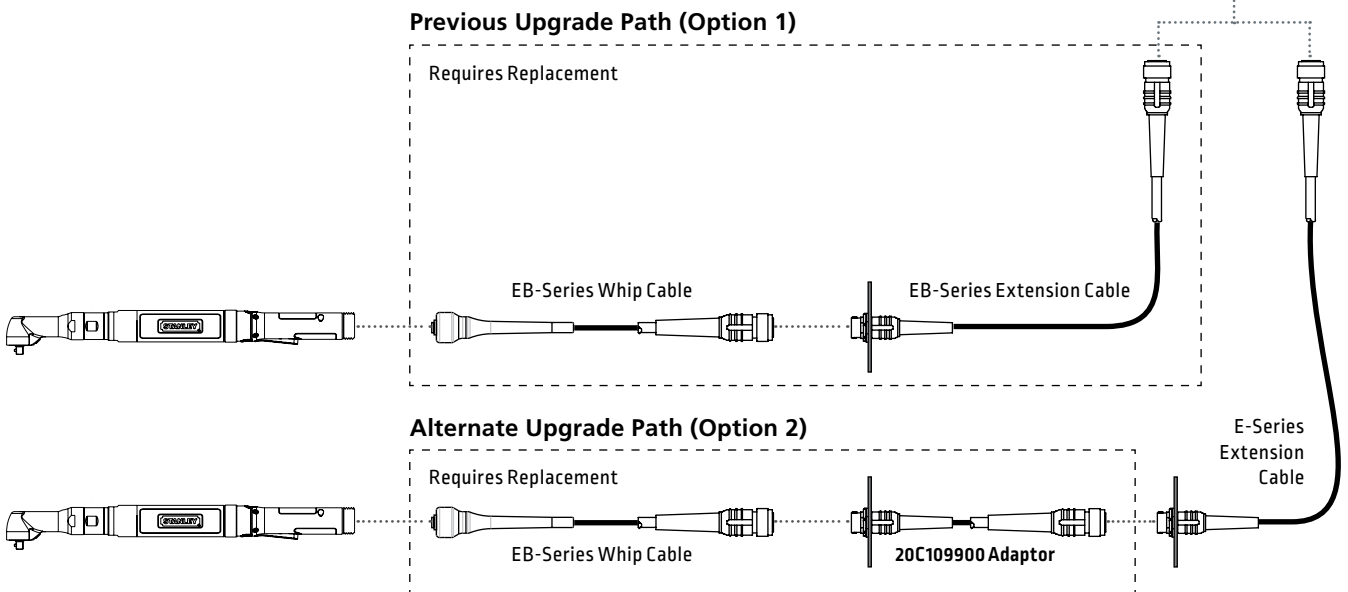



B-Series Cordless Tools

Cordless Torque Tools offering transducer-controlled battery powered tools that are ideal for threaded fastening assembly. STANLEY delivers improved productivity and quality with performance-driven torque tool solutions for the assembly floor.

COMPLETE PRODUCT LINE:

- Pistol style
- Pistol push-to-start
- Angle head lever style
- Inline lever style

FEATURES AND BENEFITS:

- Cordless Communication via IEEE 802.11 a/b/g/n
 - » 2.4 GHz to QBE Expert (QB4101), QBE Specialist (QB5100), or Network Node (QB0201)
 - » 5 GHz to customer supplied remote access points
- IEEE 802.15.4, 2.4 GHz wireless option communication to Network Node (QB0301) or QBE Specialist (QB5300)
- Accurate transducer control
- Precise, high efficiency, brushless DC motor
- Operator aided visual and audible feedback
- Controller INSIDE the tool
 - » Data storage of 500 fastening cycles and two traces
 - » 16 Jobs / 16 Tasks / 4 Steps
- Barcode Scanner option
- DEWALT Battery Platform powers STANLEY Assembly Technologies cordless tool platform



B-Series Cordless Tools



B12PB ▶
Pistol Style



B12PP ▶
Push-to-Start Style



B23LA Right Angle
Lever Style



**Specialty
Outputs**



B12LB Inline
Lever Style



B12LA Right
Angle Lever Style



Same Gearing / Output as STANLEY Corded Tools

Angle Head Output

THE STANLEY ADVANTAGE:

Only STANLEY offers a 60 Volt Cordless Tool

High Efficiency Brushless Motor



Multi-function Display Panel

Multifunction Button (MFB)

Ergonomic Lever Start Trigger

Comfort Grip Handle

Barcode Scanner or 802.15. GHz Wireless option module

Integrated Digital Control Circuit
(Inside Handle)

Battery Pack Release Button

Micro-USB Port
(Back of Handle)

Battery Pack

B33LA Right Angle Lever Style



Pistol Grip Tools

1.2 to 14 Nm

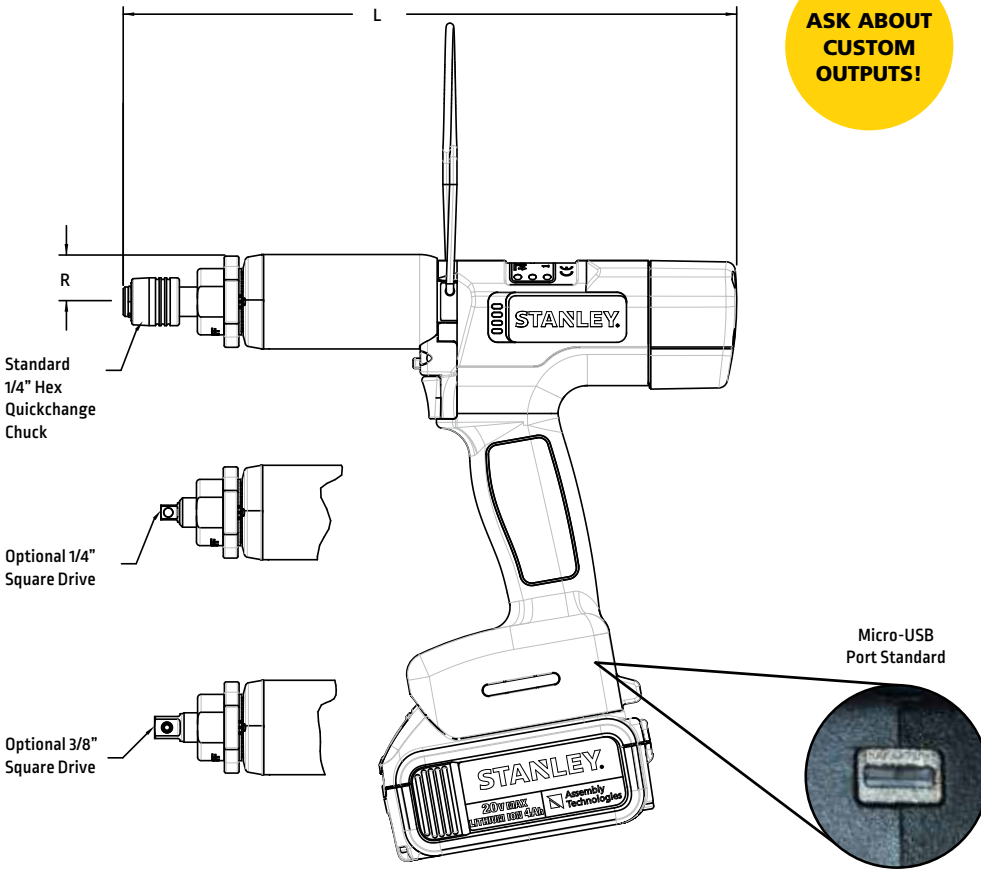

ASK ABOUT CUSTOM OUTPUTS!

Pistol Tool Options

B12 Output Options	Part No.
1/4" Square Drive	20D119302
1/4" Quick Change	20D119300
3/8" Square Drive	20D119301
Socket Lock Pin 1/4" SD	Part No.
Lock Pin Plug	A3090
Lock Pin	A3060
Spring	A3073
Socket Lock Pin 3/8" SD	Part No.
Pin Stop	L3401
Lock Pin	20D227800
Spring	20R201413
Rounded (Ball Detent)	20D227801
B12P Reaction Components	Part No.
Spacer (Default)	20D217000
Reaction Bar, Aluminum 17"	20K100103
Reaction Bar, Steel 17"	20K100104
Suspension Bail	Part No.
Wire Bail	A3061
Anti-Mar Protection	Part No.
Battery Pack Cover - 4 Ahr	20R215400
Battery Pack Cover - 2 Ahr	20R215401
Battery Pack Options	Part No.
Battery Pack, 2 Amp Hour	201R209202
Handle Options	Part No.
Barcode Scanner (Inline)	20H106100
Barcode Scanner (Push-to-Start)	20H106101
Zigbee Radio (Inline)	20H106102
Zigbee Radio (Push-to-Start)	20H106103
Programming Cable	Part No.
Programming Cable 36"	20C206600

Inline Style	Rated Speed		Torque		"R" Side to Center		"L" Length		Weight w/ Battery		Weight w/o Battery		Output	
	RPM	Nm	lb ft	mm	in	mm	in	kg	lb	kg	lb	Standard	Options	
B12PB-5	1257	5	3.7	20	0.8	264	10.4	1.82	4.0	1.14	2.5	1/4" QC	1/4" or 3/8" SD	
B12PB-8	873	8	5.9	20	0.8	264	10.4	1.82	4.0	1.14	2.5			
B12PB-11	602	11	8.1	20	0.8	264	10.4	1.82	4.0	1.14	2.5			
B12PB-15	375	15	11.0	20	0.8	264	10.4	1.82	4.0	1.14	2.5			

Push-to-Start														
Model	Rated Speed		Torque		"R" Side to Center		"L" Length		Weight w/ Battery		Weight w/o Battery		Output	
	RPM	Nm	lb ft	mm	in	mm	in	kg	lb	kg	lb	Standard	Options	
B12PP-5	1257	5	3.7	20	0.8	264	10.4	1.82	4.0	1.14	2.5	1/4" QC	1/4" or 3/8" SD	
B12PP-8	873	8	5.9	20	0.8	264	10.4	1.82	4.0	1.14	2.5			
B12PP-11	602	11	8.1	20	0.8	264	10.4	1.82	4.0	1.14	2.5			

Total vibration emission value: <2.5 m/sec² [ISO 28927-2:2009]; Sound pressure level at work station LpA [ref 20µPa] is <70dB(A) [ISO 15744-2002].

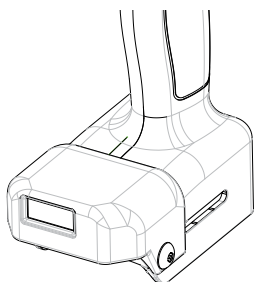

Barcode Scanner

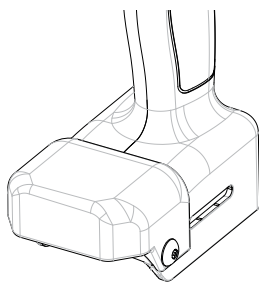

Wireless Radio

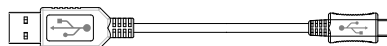

Programming Cable



Sockets and Accessories begin on page 92

Angle Head Tools

1.6 to 16 Nm

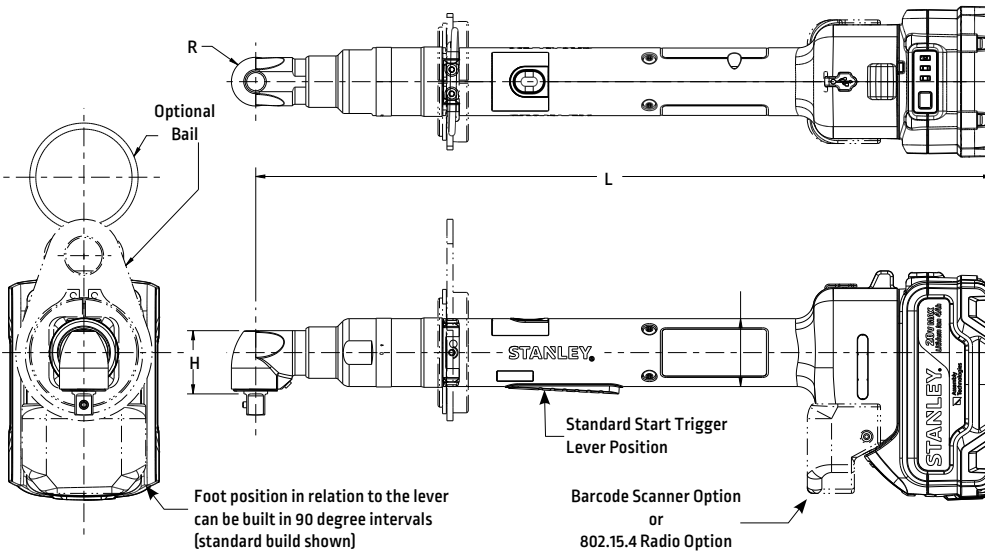

Angle Tool Options

A13 Short Output (E12 Models)	Part No.
3/8" Double-Ended, LH Thread	20D121912
3/8" Double-Ended, RH Thread	20D121917
Flush Socket 12mm Max	20D121918

Handle Options	Part No.
Barcode Scanner	20H106300
Zigbee Radio	20H106301

Model	Rated Speed		Torque		"R" Side to Center		"H" Head Height		"L" Length		Weight w/ Battery		Weight w/o Battery		Output	
	RPM		Nm	lb ft	mm	in	mm	in	mm	in	kg	lb	kg	lb	Standard	Options
B12LA13-8	838		8	5.9	13	0.5	33.2	1.3	386.1	15.2	1.65	3.65	1.04	2.3	3/8" SD	1/4"SD, 1/4"QC or Flush
B12LA13-11	582		11	8.1	13	0.5	33.2	1.3	386.1	15.2	1.65	3.65	1.04	2.3	3/8" SD	1/4"SD, 1/4"QC or Flush
B12LA13-16	401		16	11.8	13	0.5	33.2	1.3	386.1	15.2	1.65	3.65	1.04	2.3	3/8" SD	Flush

Total vibration emission value: <2.5 m/sec² [ISO 28927-2:2009]; Sound pressure level at work station LpA (ref 20µPa) is <70dB(A) [ISO 15744-2002].

Output Options

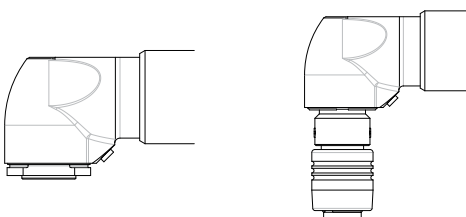

Flush

Quick Change



Sockets and Accessories
begin on page 92

Angle Head Tools

2.4 to 95 Nm

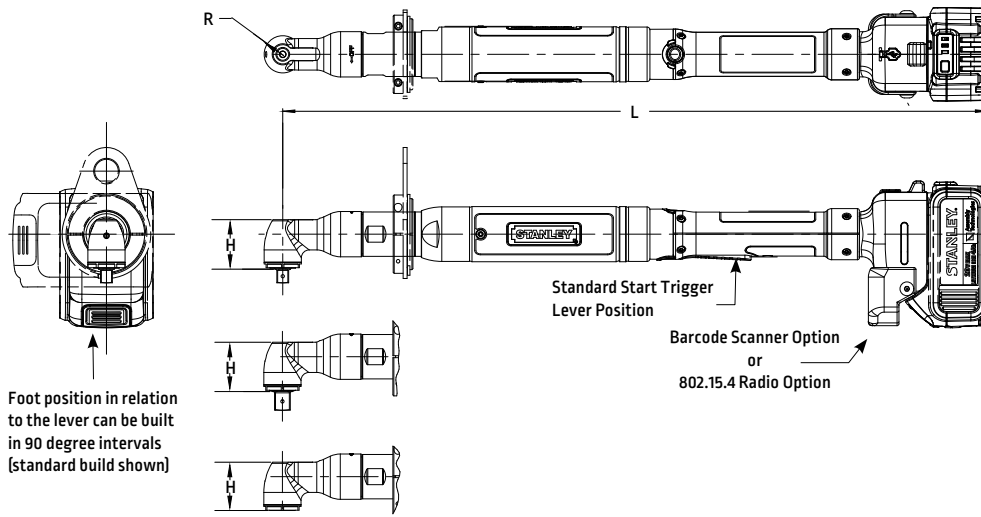

Suspension Bails	Part No.
Wire Bail	A3061
Swivel	20K101400

Handle Options	Part No.
Barcode Scanner	20H106200
Zigbee Radio	20H106202

Angle Tool Options

A15 Threaded Output 20D137503	Part No.
3/8" Square Drive	20D138908
A15 Flush Output 20D137501	Part No.
Flush Socket	20D283200
A15 Output Splined 20D137504	Part No.
3/8" Square Drive	20D138908
A15 Splined Flush 20D137505	Part No.
Flush Socket	20D283200
A18 Output	Part No.
3/8" Square Drive	20D136500
3/8" Double-Ended, RH Thread	20D136502
Flush Socket	20D136503
A19 Threaded Output	Part No.
Flush Socket	20D100021
A19 Splined Output	Part No.
Anti-Vibration 1/2" SD	20D100101
Flush Socket	20D100106
1/2" Double-Ended, RH Thread	20D100107
A22A Output	Part No.
1/2" Square Drive	20D100305
Flush Socket	20D100309
1/2" Double-Ended, RH Thread	20D100326

Model	Rated Speed		Max Torque		"R" Side to Center		"H" Head Height		"L" Length		Weight w/ Battery		Weight w/o Battery		Output	
	RPM	Nm	lb ft	mm	in	mm	in	mm	in	kg	lb	kg	lb	Standard	Options	
B23LA13-12	665	12	8.8	13	0.5	33.2	1.3	537	21.2	2.41	5.3	1.74	3.8	3/8" SD	1/4" QC	
B23LA13-15	600	15	11	13	0.5	33.2	1.3	537	21.2	2.41	5.3	1.74	3.8	3/8" SD	1/4" QC	
B23LA13-17	460	17	12.5	13	0.5	33.2	1.3	537	21.2	2.41	5.3	1.74	3.8	3/8" SD	1/4" QC	
B23LA15-23	370	23	17	15	0.59	39.9	1.57	552	21.8	2.58	5.7	1.95	4.3	3/8" SD	1/2" SD	
B23LA15-35	230	35	25.8	15	0.59	39.9	1.57	567	22.4	2.65	5.8	1.98	4.4	3/8" SD	1/2" SD	
B23LA18-42	180	42	31	18	0.71	39.9	1.57	563	22.2	2.83	6.2	2.11	4.6	3/8" SD	1/2" SD	
B23LA19-52	155	52	38.3	19	0.75	47.8	1.9	592	23.4	2.99	6.6	2.32	5.1	1/2" SD		
B23LA19-70	140	70	51.6	19	0.75	47.8	1.9	653	25.7	3.61	7.9	2.95	6.5	1/2" SD		
B23LA22A-95	105	95	70	22	0.87	47.9	1.9	660	26.0	3.61	7.9	3.45	7.6	1/2" SD		

Total vibration emission value: <2.5 m/sec² [ISO 28927-2:2009]; Sound pressure level at work station LpA (ref 20µPa) is <70dB(A) [ISO 15744-2002].



Sockets and Accessories
begin on page 92

Angle Head Tools

2.8 to 95 Nm

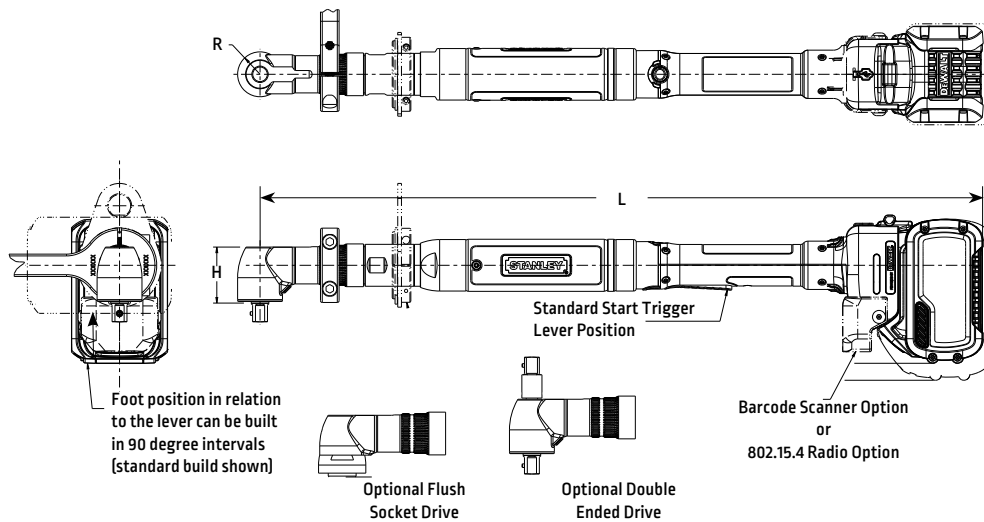

Reaction Components	Part No.
Reaction Bar, Steel (<300 Nm)	20K100200
Reaction Bar, Steel (>300 Nm)	20K100202
Base Mount Bracket	20K100600
Mounting Flange	20K100300

Handle Options	Part No.
Barcode Scanner	20H106201
Zigbee Radio	20H106203

B33 / B44 Batteries	Part No.
60V MAX/ 2AH Battery	21R209203
60V MAX/ 3AH Battery	21R209204
60V MAX/ 20V MAX Fast Charger	21R209402

Suspension Bails	Part No.
Wire Bail	A3061
Swivel	20K101400

Model	Rated Speed	Max Torque		"R" Side to Center		"H" Head Height		"L" Length*		Weight w/ Battery*		Weight w/o Battery		Output	
	RPM	Nm	lb ft	mm	in	mm	in	mm	in	kg	lb	kg	lb	Standard	Options
B33LA13-14	1698	14	10.3	13	0.5	33.2	1.3	561.7	22.1	2.77	6.1	1.72	3.8	3/8" SD	1/4" SD or 1/4" QC
B33LA13-18	1372	18	13.3	13	0.5	33.2	1.3	561.7	22.1	2.77	6.1	1.72	3.8	3/8" SD	1/4" SD or 1/4" QC
B33LA15-25	959	25	18.5	15	0.59	39.9	1.57	576.8	22.7	2.99	6.6	1.95	4.3	3/8" SD	
B33LA15-40	525	40	29.5	15	0.59	39.9	1.57	592	23.3	3.04	6.7	2.0	4.4	3/8" SD	
B33LA18-48	455	48	35.4	18	0.71	39.9	1.57	587.5	23.1	3.13	6.9	2.09	4.6	3/8" SD	
B33LA19-55	439	55	40.6	19	0.75	47.8	1.9	617	24.3	3.36	7.4	2.31	5.1	1/2" SD	
B33LA19-70	356	70	51.6	19	0.75	47.8	1.9	677.5	26.7	3.99	8.8	2.95	6.5	1/2" SD	
B33LA22A-95	237	95	70	22	0.87	47.9	1.9	685.2	27.0	4.17	9.2	3.13	6.9	1/2" SD	

Total vibration emission value: <2.5 m/sec² [ISO 28927-2:2009]; Sound pressure level at work station LpA [ref 20µPa] is <70dB(A) [ISO 15744-2002].

*Dimensions and weights are with the standard 60V Max/ 2AH Battery

Angle Tool Options

A13 Short Output	Part No.
3/8" Double-Ended, LH Thread	20D121912
3/8" Double-Ended, RH Thread	20D121917
Flush Socket 12mm Max	20D121918
1/4" Square Drive	20D121919
1/4" Quick Change	20D121916
1/4" Magnetic Internal Hex	20D121920

A15 Threaded Output 20D137503	Part No.
3/8" Square Drive	20D138908

A15 Flush Output 20D137501	Part No.
Flush Socket	20D283200

A15 Output Splined 20D137504	Part No.
3/8" Square Drive	20D138908

A15 Splined Flush 20D137505	Part No.
Flush Socket	20D283200

A18 Output	Part No.
3/8" Square Drive	20D136500
3/8" Double-Ended, RH Thread	20D136502
Flush Socket	20D136503

A19 Threaded Output	Part No.
Flush Socket	20D100021

A19 Splined Output	Part No.
Anti-Vibration 1/2" SD	20D100101
Flush Socket	20D100106
1/2" Double-Ended, RH Thread	20D100107

A22A Output	Part No.
1/2" Square Drive	20D100305
Flush Socket	20D100309
1/2" Double-Ended, RH Thread	20D100326

Angle Head Tools

11 to 120 Nm

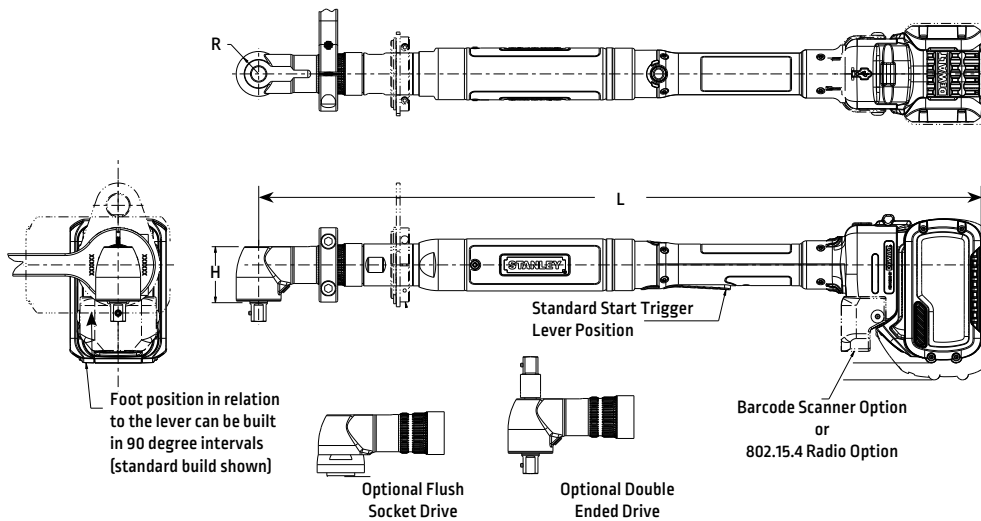

Angle Tool Options

A19 Threaded Output	Part No.
Flush Socket	20D100021
A19 Splined Output	Part No.
Anti-Vibration 1/2" SD	20D100101
Flush Socket	20D100106
1/2" Double-Ended, RH Thread	20D100107
A22A Output	Part No.
1/2" Square Drive	20D100305
Flush Socket	20D100309
1/2" Double-Ended, RH Thread	20D100326

B33 / B44 Batteries	Part No.
60V MAX/2AH Battery	21R209203
60V MAX/3AH Battery	21R209204
60V MAX/20V MAX Fast Charger	21R209402

Reaction Components	Part No.
Reaction Bar (Default)	20K100000
Mounting Flange	20K100300
Base Mount Bracket	20K100500

Handle Options	Part No.
Barcode Scanner	20H106201
Zigbee Radio	20H106203

Suspension Bails	Part No.
Swivel (Horizontal)	20K200000
Standard (Vertical)	A3061

Model	Rated Speed		Max Torque		"R" Side to Center		"H" Head Height		"L" Length*		Weight w/ Battery*		Weight w/o Battery		Output	
	RPM		Nm	lb ft	mm	in	mm	in	mm	in	kg	lb	kg	lb	Standard	Options
B44LA19-55	573		55	40.6	19	0.75	47.8	1.9	715.3	28.2	5.2	11.5	3.94	8.69	1/2" SD	
B44LA19-70	425		70	51.6	19	0.75	47.8	1.9	715.3	28.2	5.2	11.5	3.94	8.69	1/2" SD	
B44LA22A-95	328		95	70	22	0.87	47.9	1.9	723.0	28.5	5.4	11.9	4.11	9.06	1/2" SD	
B44LA22A-120	243		120	88.5	22	0.87	47.9	1.9	723.0	28.5	5.4	11.9	4.11	9.06	1/2" SD	

Total vibration emission value: <math><2.5 \text{ m/sec}^2</math> [ISO 28927-2:2009]; Sound pressure level at work station L_{pA} [ref $20\mu\text{Pa}$] is <math><70 \text{ dB(A)}</math> [ISO 15744-2002].

*Dimensions and weights are with the standard 60V Max/ 2AH Battery



Sockets and Accessories
begin on page 92

Inline Tools

1 to 11 Nm

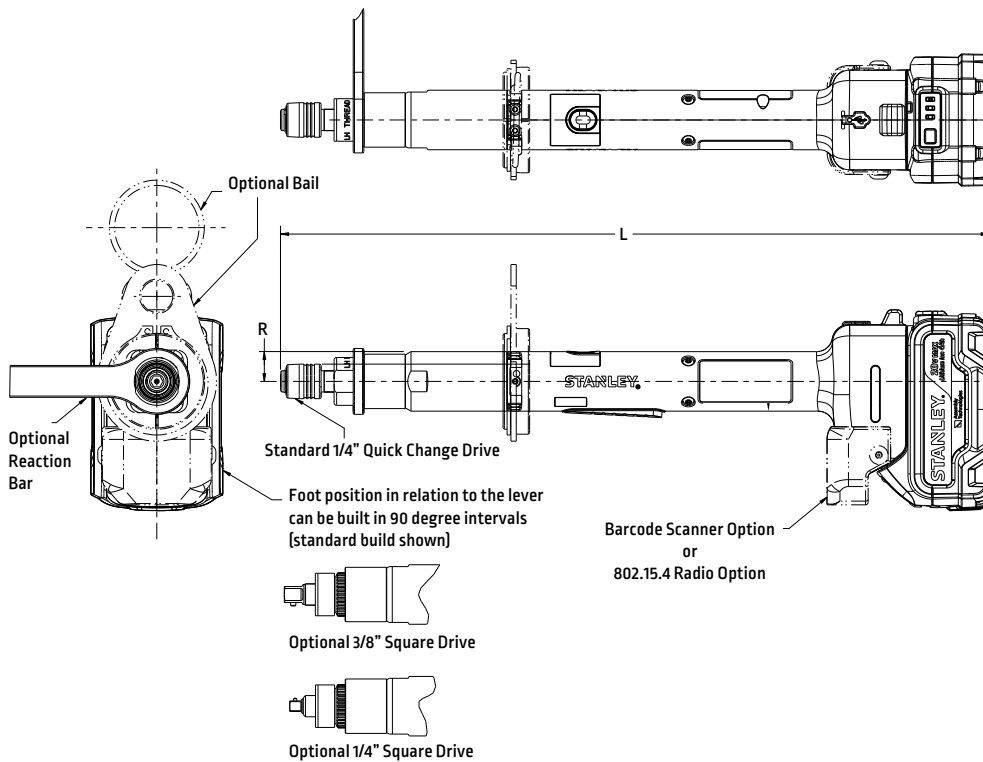

Inline Tool Options

Output Options	Part No.
3/8" Square Drive	20D119301
1/4" Quick Change	20D119300
1/4" Square Drive	20D119302
3/8" SD Socket Lock Pin	Part No.
Standard	20D227800
Rounded (Ball Detent)	20D227801
Reaction Components	Part No.
Reaction Bar, Aluminum (Default)	20K100103
Reaction Bar, Steel	20K100104
Spacer	20D217000
Suspension Bails	Part No.
Wire Bail	A3061
Swivel	20K101402

Model	Rated Speed		Max Torque		"R" Side to Center		"L" Length		Weight w/ Battery		Weight w/o Battery		Output	
	RPM		Nm	lb ft	mm	in	mm	in	kg	lb	kg	lb	Standard	Options
B12LB-5	1257		5	3.7	17.8	0.7	423.5	16.7	1.45	3.21	0.82	1.81	1/4"QC	1/4"SD or 3/8"SD
B12LB-8	873		8	5.9	17.8	0.7	423.5	16.7	1.45	3.21	0.82	1.81	1/4"QC	1/4"SD or 3/8"SD
B12LB-11	602		11	8.1	17.8	0.7	423.5	16.7	1.45	3.21	0.82	1.81	1/4"QC	1/4"SD or 3/8"SD
B12LP-5	1257		5	3.7	20.4	0.8	423.5	16.7	1.45	3.21	0.82	1.81	1/4"QC	1/4"SD or 3/8"SD
B12LP-8	873		8	5.9	20.4	0.8	423.5	16.7	1.45	3.21	0.82	1.81	1/4"QC	1/4"SD or 3/8"SD
B12LP-11	602		11	8.1	20.4	0.8	423.5	16.7	1.45	3.21	0.82	1.81	1/4"QC	1/4"SD or 3/8"SD

Total vibration emission value: <math><2.5 \text{ m/sec}^2</math> [ISO 28927-2:2009]; Sound pressure level at work station LpA [ref 20μPa] is <math><70 \text{ dB(A)}</math> [ISO 15744-2002].

Tubenut / Crowfoot Tools

2.6 to 50 Nm

Two Hand Anti Tiedown Options (Tubenut & Crowfoot)

2-Hand Anti Tiedown	Part No.
B23/B33	20H106405

Tubenut

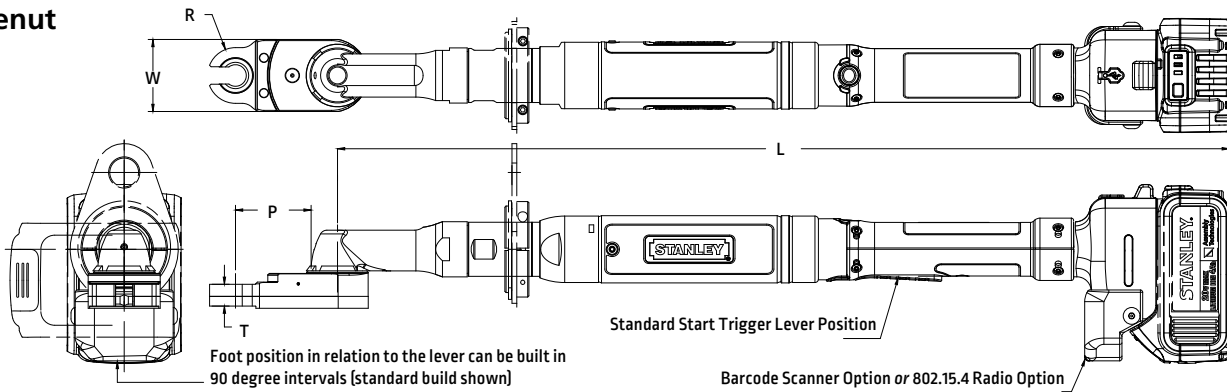

Model	Rated Speed	Max Torque		"R" Nose Radius		"T" Thickness		"W" Width		"P" Length		"L" Length		Weight		Maximum Hex Size		Maximum Tube Size	
	RPM	Nm	lb ft	mm	in	mm	in	mm	in	mm	in	mm	in	kg	lb	mm	in	mm	in
B23LT252-21	260	21	15.5	13	0.52	14	0.54	42	1.66	56	2.20	525	20.7	2.5	5.6	13	1/2	9.3	0.37
B23LT346-23	250	23	16.9	13	0.52	14	0.56	42	1.66	34	1.34	644	25.4	2.4	5.3	13	0.5	9.4	0.37
B23LT74-30	305	30	22.1	18	0.73	14	0.56	48	1.88	44	1.72	657	25.9	2.5	5.6	18	11/16	11.6	0.46
B23LT473-31	195	31	22.9	18	0.73	14	0.56	48	1.88	39	1.53	593	23.3	2.4	5.3	18	11/16	11.6	0.46
B23LT264-38	150	38	28.0	21	0.84	18	0.70	54	2.13	77	3.03	665	26.2	2.5	5.6	24	15/16	18.2	0.72
B23LT264-50	100	50	36.9	21	0.84	18	0.70	54	2.13	77	3.03	648	25.5	2.5	5.6	24	15/16	18.2	0.72
B33LT264-50	267	50	36.9	21	0.84	18	0.7	54	2.13	77	3.03	671.5	26.44	2.27	5	24	15/16	18.2	0.72
B44LT99-62	299	62	45.7	26	1.04	19	0.77	75	2.94	65	2.55	715.5	28.17	3.95	8.7	27	1-1/16	19	.755

Total vibration emission value: <2.5 m/sec² [ISO 28927-2:2009]; Sound pressure level at work station LpA (ref 20µPa) is <70dB(A) [ISO 15744-2002].

Crowfoot

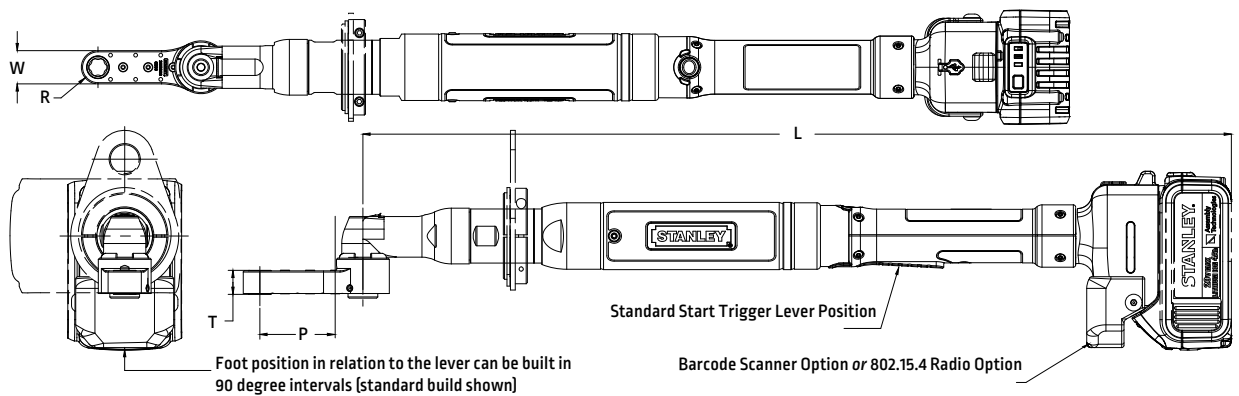

Model	Rated Speed	Max Torque		"R" Nose Radius		"T" Thickness		"W" Width		"P" Length		"L" Length		Weight		Maximum Hex Size	
	RPM	Nm	lb ft	mm	in	mm	in	mm	in	mm	in	mm	in	kg	lb	mm	in
B23LC550-13	460	13	9.6	13	0.5	9	0.37	25	1.00	77	3.05	629	24.8	2.5	5.6	13	0.5
B23LC624-14	478	14	10.3	21	0.81	14	0.55	38	1.5	75	2.95	582.2	22.92	2.4	5.3	19	0.75
B23LC390-15	335	15	11	11	0.43	16	0.63	22	0.87	51	1.99	642	25.3	2.4	5.3	13	0.5
B23LC477-15	383	15	11.1	12	0.47	16	0.63	32	1.25	161	6.33	714.3	28.12	2.6	5.73	13	0.5
B23LC501-18	340	18	13.3	13	0.52	17	0.65	38	1.48	123	4.85	728.5	28.68	2.27	5	15	0.625
B23LC216-26	225	26	19.1	13	0.5	14	0.56	30	1.19	47	1.86	660	26	2.4	5.3	13	0.5
B23LC521-30	180	30	22.1	13	0.5	16	0.63	32	1.25	45	1.76	611	24	2.5	5.6	13	0.5
B23LC29-37	160	37	27.3	21	0.81	14	0.56	38	1.50	43	1.70	590	23.2	2.5	5.6	19	0.75
B23LC566-38	155	38	28.0	21	0.81	21	0.81	38	1.50	43	1.70	593	23.3	2.4	5.3	19	0.75
B33LC601-65	237	65	47.9	21	0.81	17	0.66	38	1.5	71	2.78	780.5	30.73	2.72	6	19	0.75

Hold and Drive Tools

8.4 to 42 Nm

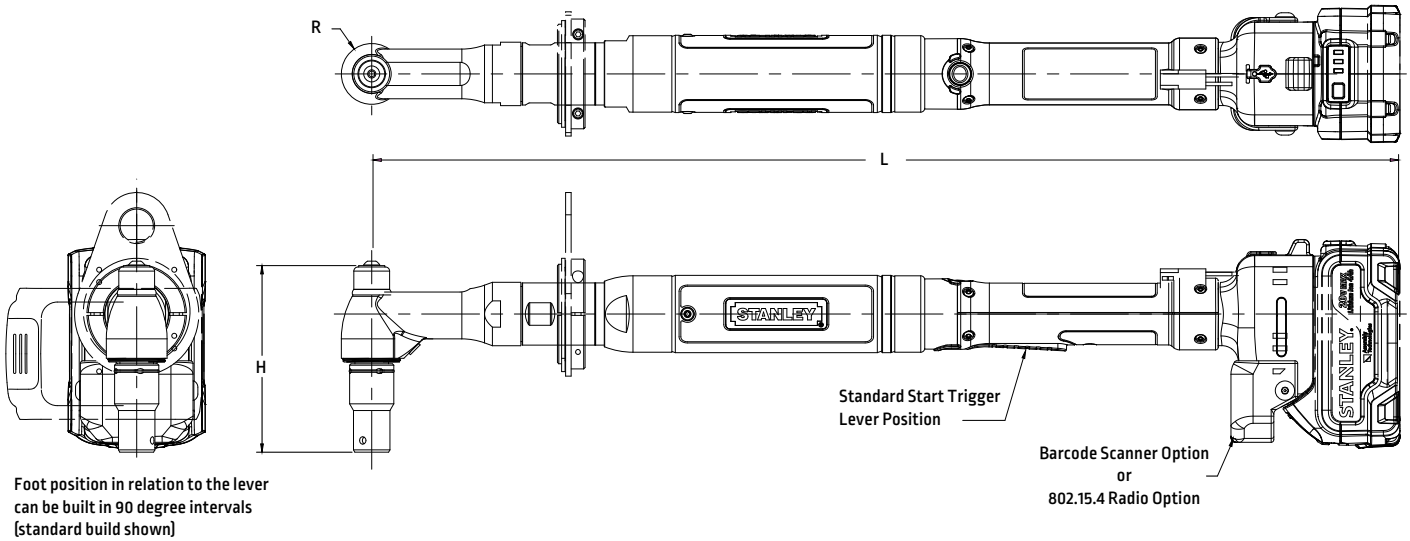

Model	Rated Speed		Max Torque		"R" Side to Center		"H" Head Height		"L" Length		Weight		Travel
	RPM	Nm	lb ft	mm	in	mm	in	mm	in	kg	lb	Standard	
B23LH18V1-42	200	42	31	18	0.69	109	4.28	590	23.2	2	4.5	1" Tang	
B23LH18V2-42	200	42	31	18	0.69	109	4.28	590	23.2	2.2	4.9	2" Tang	
B23LH22AV1-80	103	80	59	22	0.87	115.06	4.53	612.8	24.1	3	6.6	1" Tang	
B23LH22AV2-80	103	80	59	22	0.87	148.2	5.84	612.8	24.1	3.2	7.1	2" Tang	

Total vibration emission value: <math><2.5 \text{ m/sec}^2</math> [ISO 28927-2:2009]; Sound pressure level at work station LpA [ref 20μPa] is <math><70 \text{ dB(A)}</math> [ISO 15744-2002].

See pages 106-117 for the Hold and Drive Configuration Guide

Hold and Drive Options

A Tang holds the bolt while the nut is tightened

A Bit holds the bolt while the nut is tightened

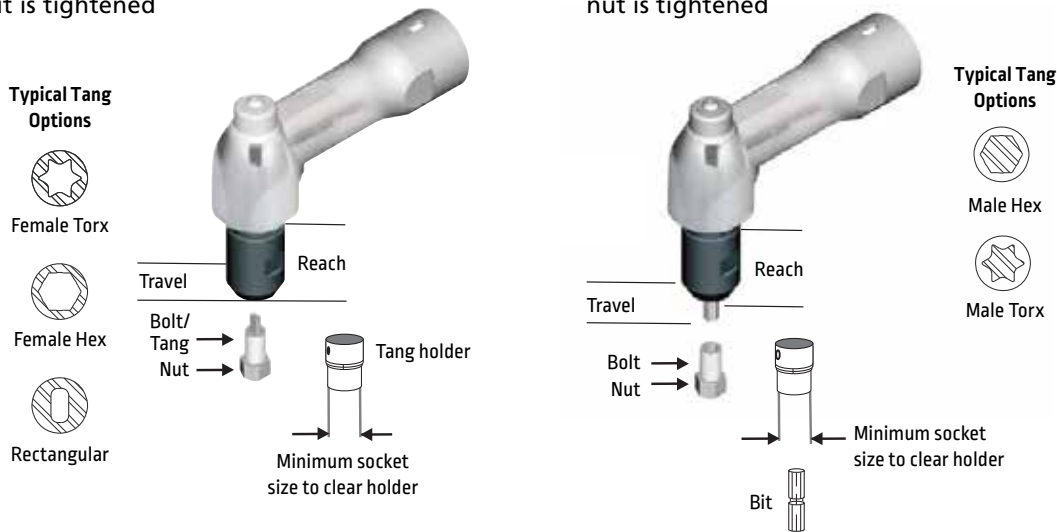

NOTE: The bolt can extend beyond the nut no more than the specified travel distance when tightened.

DEWALT Lithium Batteries and Chargers

DEWALT 20V, 2 AH AND 5 AH (18 VOLT, 5AH EUROPEAN MODEL) PLATFORM

- » Estimated 2,200 fastening cycles per charge for 5 Ah*
- » 3-LED Fuel Gauge indicator for immediate feedback on state of charge

DEWALT 60V, 2 AH AND 3 AH (54 VOLT, 2 AH EUROPEAN MODEL) PLATFORM

- » Estimated 3,300 fastening cycles per charge for 2 Ah*
- » 3-LED Fuel Gauge indicator for immediate feedback on state of charge

STANLEY Assembly Technologies cordless tools ship with one battery pack and one charger (North America only). Additional battery packs and chargers may be ordered separately:

	ITEM	DESCRIPTION
N. AMERICA (NA)	21R209202	20V Battery Pack, 2 Ah
	21R209205	20V Battery Pack, 5 Ah
	21R209402	20V / 60V Battery Charger
	21R209203	60V, 2 Ah / 20V, 6 Ah Battery Pack
	21R209204	60V, 3 Ah / 20V, 9 Ah Battery Pack
EUROPE	N566456	Battery Pack, 18V 2 Ah
	E008 500	Battery Pack, 18V, 5 Ah
	N630880	Charger 18V/54V/SINGLE/DCB118-QW
	N630919	Battery 54, 2 Ah/18V, 6 Ah -108Wh-DCB546-XJ
	N630923	Battery 54, 3 Ah/18V, 9 Ah -162Wh-DCB547-XJ
	N630885	Charger, 18V/54V/SINGLE/DCB118-UK
	N630892	Charger, 18V/54V/DOUBLE/DCB132-Europe
	N630896	Charger, 18V/54V/DOUBLE/DCB132-UK

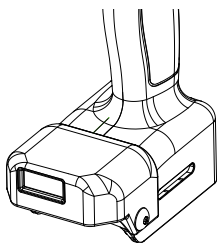

Barcode Scanner Option

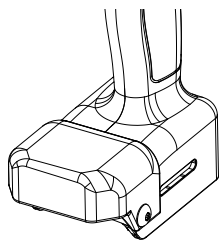

802.15.4 Wireless Radio Option

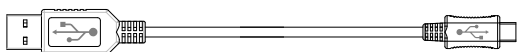

Programming Cable

OPTIONS**			
Barcode Scanner		802.15.4 Radio	
B12 Pistol Grip	20H106100	B12 Pistol Grip	20H106102
B12 Push-to-Start Pistol	20H106101	B12 Push-to-Start Pistol	20H106103
B12 Lever Style	20H106300	B12 Lever Style	20H106301
B23 Lever Style	20H106200	B23 Lever Style	20H106202
B33/B44 Lever Style	20H106201	B33/B44 Lever Style	20H106203

ACCESSORIES	
Programming Cable	20C206600

*Dependent on application and joint rate

**QPM Cordless tool can accommodate one option (e.g., a barcode scanner OR an IEEE 802.15.4 radio)



Shown: 21R209204 —
DEWALT 60V, 3 Ah / 20V, 9Ah Battery Pack, NA



Shown: 21R209205 —
DEWALT 20V, 5 Ah Battery Pack, NA



Shown: 21R209402 — DEWALT 20V /
60V Battery Charger, NA

PROTECTIVE BOOT COVERS



20R215400 for 20V /
5 Ah battery pack



20R215401 for 20V /
2 Ah battery pack

Option/Accessory Quick Reference Chart

Accessory	EB Series (Corded Tools)								B Series (Cordless Tools)					
	Lever								Pistol	Lever				Pistol
	Angle				Inline					Angle			Inline	
	EB12	EB22/33	EB34/44	EB45/55	EB12	EB22/33	EB34/44	EB45/55	EB12	B12	B23/33	B44	B12	B12
6 - 13 Nm	13 - 60 Nm	55 - 120 Nm	120 - 400 Nm	2 - 14 Nm	16 - 40 Nm	55 - 120 Nm	140 - 2000 Nm	2 - 14 Nm	8 - 16 Nm	12 - 95 Nm	55 - 120 Nm	5 - 11 Nm	5 - 11 Nm	
Wire (Suspension) Bail	Std	Opt	Opt	N/A	Std	Opt	Opt	N/A	Std	Std	Opt	Opt	Std	Std
Swivel Bail	Opt	Opt	Opt	Opt	Opt	Opt	Opt	Opt	N/A	Opt	Opt	Opt	Opt	N/A
Reaction Bar	N/A	N/A (Std only over 50 Nm)	Std	Std	Std	Std	Std	Std	Opt	N/A	N/A (Std only over 50 Nm)	Std	Opt (Std only on push to start)	Opt
Rubber Grip	Avail	Avail	Avail	Avail	Avail	Avail	Avail	Avail	Avail	N/A	N/A	N/A	N/A	N/A
Headlights	N/A	Opt (EB33)	Opt (EB34)	N/A	N/A (Std only on push to start)	Opt (EB33)	Opt (EB34)	N/A	Std	N/A	Opt	N/A	N/A (Std only on push to start)	Std
Forward Facing Lever	N/A	Avail	Avail	Avail	N/A	Avail	Avail	Avail	N/A	Avail	Avail	N/A	Avail	N/A
Extended Lever	Avail	Avail	Avail	Avail	Avail	Avail	Avail	Avail	N/A	Avail	N/A	N/A	Avail	N/A
Two Hand Switch	N/A	Opt (EB33)	Opt	Opt	N/A	Opt (EB33)	Opt	Opt	N/A	N/A	Opt	N/A	N/A	N/A
Top Exit	N/A	N/A	N/A	N/A	N/A	N/A	N/A	N/A	Opt	N/A	N/A	N/A	N/A	Opt
Barcode Scanner or Zigbee	N/A	N/A	N/A	N/A	N/A	N/A	N/A	N/A	N/A	Opt	Opt	Opt	Opt	Opt



STANLEY ASSEMBLY TECHNOLOGIES QBE CONTROLLERS

QBE Controllers

THE QBE CONTROLLER PLATFORM delivers industry-leading advanced process control, system configuration flexibility, ease of set-up options both on-screen and with embedded software utilities, and exceedingly high performance. From an error proofing system to assembly line control system, STANLEY QBE Controllers are the standard for all others in precision threaded fastening control.

THE QBE CONTROLLER PLATFORM FEATURES:

- **Low Cost of Ownership:** Single control platform for the complete range of STANLEY Assembly Technologies Tools to 2000 Nm, handheld and fixtured.
- **Durability:** All controllers have an Ingress Protection rating 54 (IP 54)
- **Flexibility:** Connectivity options include 24V I/O, USB, Ethernet, Serial and Fieldbus
- **Ease of Use:** QBE Expert, Specialist, Advanced and Standard controllers can be setup from the front panel or from a computer's web browser using the Alpha Toolbox Ethernet connection
- **Intelligent Connectivity:** Alpha Toolbox, included in every QBE Controller, is used to program strategies, collect fastening cycle and trace data, and perform online diagnostics of the tool and controller (see page 84)
- **Intuitive Design:** The Wizard provides an easy method to control programming directly from the keypad on the controller or with Alpha Toolbox software
- **Inexpensive Upgrade Path:** The QBE Controller is designed to power the complete STANLEY Assembly Technologies tool product line:
 - » EB-Series Coded Tools
 - » EB-Series Coded Fixtured Tools
 - » B-Series Cordless Tools
 - » E-Series Coded and Fixtured Tools
 - » Previous generations (EA-Series and EC-Series Tools)

The QBE Controller platform includes options that are based on our customer's requirements. Please choose from our range of controller options:

- **QBE Expert Controller** is the premier Single Tool Controller and Lead Controller in a Multi-Spindle System
- **QBE Specialist Controller** is a Multi-Spindle and Cordless Tool Controller
- **QBE Advanced Controller** is a Single Spindle Controller or a Lead Controller for a Dual-Spindle System
- **QBE Standard Plus Controller** is a Single Spindle Controller without Ethernet or Fieldbus Options
- **QBE Node Controller** is a Single Spindle Controller used for trailing spindles in Multiple Tool (Fixtured) Applications or in Multi-Tool Systems
- **QBE Network Node Controller** is a Cordless Tool Controller for up to 6 B-Series Cordless Tools

SPECIFICATIONS FOR QBE CONTROLLERS:

- **Dimensions (W x H x D):** 15 cm x 36 cm x 26 cm (6 in x 14 in x 10 in)
- **Weight:** 7.6 kg (16.7 lb)
- **I/O Power Supply:** 24V DC, 1A Internal, Ready for External Power Supply
- **AC Power Source:** Auto Detect 100 – 126.5V or 200 – 253V AC, 50 or 60 Hz
- **Humidity:** 0 to 95% non-condensing
- **Temperature:** 32 – 122 °F (0 – 50 °C)



How to Order

STEP 1: Refer to the matrix on the specific controller page to identify the Model Number and Options based requirements.

STEP 2: Select a power cord by the supply voltage and country, if required. Or select No Power Cord.

Power Cord Description	Part No.
Argentina Power Cord 230V, 2m	20C105202
Australia Power Cord 230V, 2m	20C102103
Brazil Power Cord 230V, 2m	20C102104
China Power Cord 230V, 2m	21C103905
Euro Power Cord 230V, 2m	20C102102
Japan Power Cord 125V, 2m	20C102101
Japan Power Cord 250V, 2m	20C102105
US Power Cord 115V, 2m	20C102002
US Power Cord 115V, 7m	20C102007
US Power Cord 230V, 2m	21C103902

Power Cord Description	Part No.
UK Power Cord 230V, 2m	20C102202
Power Distribution Panel Cord, 1m	20C203401
Power Distribution Panel Cord, 2m	20C203402
Twist Lock Power Cord 115V, 2m	20C103802
Twist Lock Power Cord 115V, 4m	20C103804
Twist Lock Power Cord 115V, 7m	20C103807
Twist Lock Power Cord 230V, 2m	20C106302
Twist Lock Power Cord 230V, 7m	20C106307
GFI 30ma 250V Assembly for Europe	21E102300
India Power Cord 250V, 2m	20C102106

STEP 3: A plinth is selected as standard. If no plinth is required, select No Plinth.

STEP 4: Select I/O Cable options, if required.

I/O Mating Connector Description	Standard/Optional	Part No.
24V I/O Mating Connector, Phoenix for Basic Alpha	Standard	21C104806
24V I/O Mating Connector, Solder Cup (Standard, Advanced, Expert, Network Node)	Standard	21C104800
24V I/O Mating Connector, Crimp Pins (Standard, Advanced, Expert, Network Node)	Optional	21C104802
24V I/O Mating Connector, Crimp Pins, with Crimp Tool (Standard, Advanced, Expert, Network Node)	Optional	21C104804
5M, 24V I/O Ext. Cable (I/O Connector to Pigtail)	Optional	21C202005
20M, 24V I/O Ext. Cable (I/O Connector to Pigtail)	Optional	21C202010
10M, 24V I/O Ext. Cable (I/O Connector to Pigtail)	Optional	21C202020
I/O Bracket Assembly, 19-Pin to Phoenix	Optional	21E102202

STEP 5: Select a floor stand, if required.

Floor Stand Description	No. of Spindles	Dimensions	Part No.
Floor Stand Kit	1 to 6	198H x 61W x 56D cm	21F100404
Assembled System with Floor Stand	1 to 6	78H x 24W x 22D in	Add /F to Model No.
Floor Stand Kit	7 to 12	198H x 61W x 88D cm	21F100402
Assembled System with Floor Stand	7 to 12	78H x 24W x 34.5D in	Add /F to Model No.

Please Note: If UL or CSA certification are required, please contact the STANLEY team to have this quoted to you.

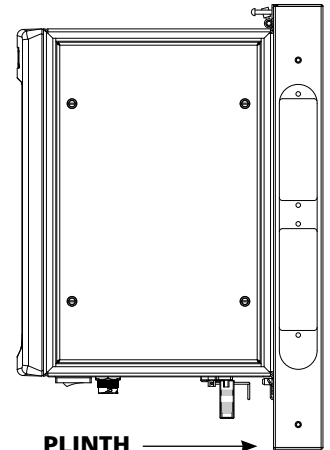

PLINTH →

- Quick-change mounting by hand
- Cable management and routing

FLOOR STAND

- Top row of controllers require a 90° Extension.
- See pages 52-55 for Cable Options

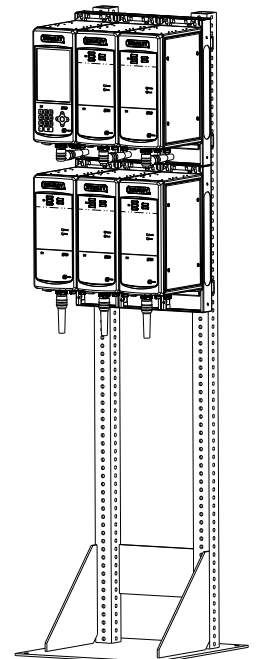

QBE Expert Controller



QBE Expert Controller is the premier Multi-Spindle Controller

BENEFITS:

- Large Touchscreen, Color Display and Keypad
- Quick Set-up from the Controller Keypad, or with a PC, tablet, or smart phone
- Alpha Toolbox, STANLEY's web-based software for programming, collecting data and performing diagnostics
- Less training, less inventory and spare parts: STANLEY offers the same Controller platform for Cordless B-Series Battery Tools as well as Corded Handheld and Fixtured EB-Series, E-Series and EA-Series Tools

TECHNICAL FEATURES:

- One Network Connection for Multiple Spindles
- Operates as a Standalone Controller or as the Lead Controller of a multiple (fixtured) system
- Manages up to 24 trailing spindles (Advanced or Nodes) or Cordless Tools
- A maximum of 15 Cordless Connections are supported
- An 802.11 b/g/n wireless access point for B-Series Cordless Tools to connect as trailing spindles
- Stores Trace Data for 30,000 Fastening Cycles for Corded Tools
- 255 jobs, 99 tasks, 12 steps including smart steps and all advanced strategies
- Includes a USB port, a plant network Ethernet port, a Spindle network Ethernet port, a Serial port, and an emulated PLC function
- Embedded Modbus TCP
- Fieldbus options: Profibus, Profinet, DeviceNet and Ethernet IP
- 24V DC I/O, 8 Inputs / 8 Outputs, assignable

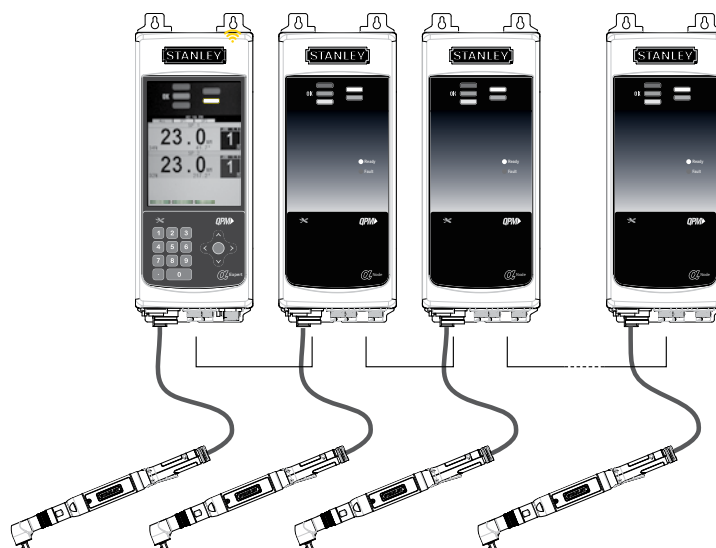

Spindles 1-24 connect using an isolated Ethernet Spindle Network

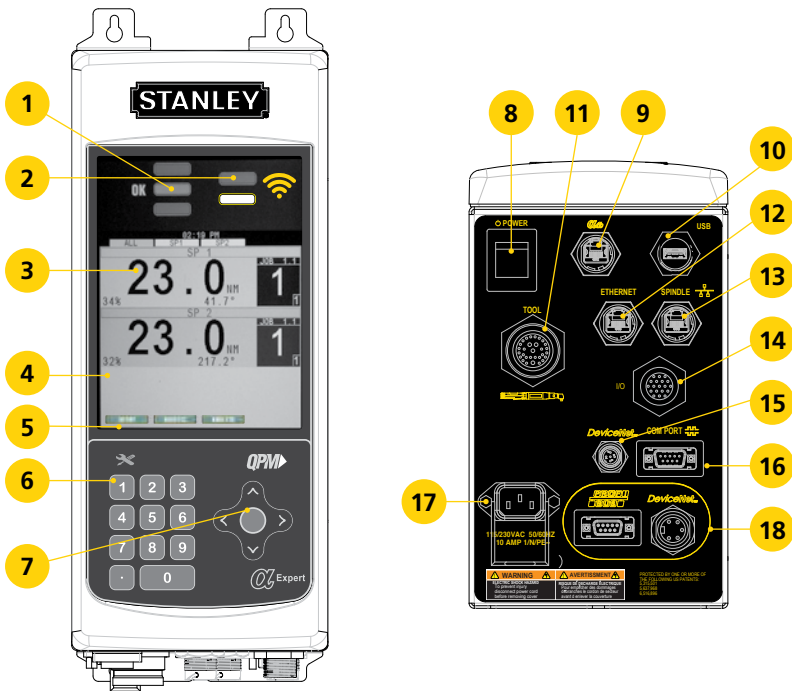

Description	
1	Red, Green, Yellow LEDs for Limits Evaluation
2	Programmable and Tool Ready LEDs
3	Display
4	Function Keys with Active Label Above
5	Maintenance Due Indicator
6	Numeric Keypad to Enter Numbers or Select Options
7	Cursor Keys with Center Button to Expand Lists
8	Power Switch
9	Alpha Toolbox Connector
10	USB Port for Data Transfer
11	Tool Connector
12	Plant Network Ethernet Connector
13	Spindle Network Ethernet Connector
14	24V DC Input/Output Connector
15	Optional Master DeviceNet Connector
16	Serial Port Connector
17	Power Input
18	Optional Fieldbus Connector(s)

Standard Features	Serial	Ethernet	USB	24V DC I/O	Modbus/TCP	Alpha Toolbox
All Models	✓	✓	✓	✓	✓	✓

Note: M12 Ethernet port available upon request. Contact STANLEY for more details.

Alpha Model Number for Optional Features	DeviceNet	PROFIBUS	EtherNet/IP	PROFINET	GMP Ports	Lead DeviceNet Available	M12 EtherNet/IP ports
QB4101-MGV					✓	✓	
QB4101-MXV						✓	
QB4101-XEV			✓				
QB4101-XDV	✓						
QB4101-XGV				✓			
QB4101-XMV		✓					✓
QB4101-XNV			✓				
QB4101-XPV		✓					
QB4101-XXV							



QBE Specialist Controller



QBE Specialist Controller is a Multi-Spindle and Cordless Tool Controller

BENEFITS:

- Large Touchscreen, Color Display and Keypad
- Quick Set-up from the Controller Keypad, or with a PC, tablet, or smart phone
- Alpha Toolbox, STANLEY's web-based software for programming, collecting data and performing diagnostics
- Less training, less inventory and spare parts: STANLEY offers the same Controller platform for Cordless B-Series Battery Tools as well as Corded Handheld and Fixtured EB-Series, E-Series and EA-Series Tools

TECHNICAL FEATURES:

- Large touchscreen, color display and on-screen keypad
- Operates as the Lead Controller of a multiple (fixtured) system and manages up to 24 trailing spindles (Advanced or Nodes) or Cordless Tools
- A maximum of 15 Cordless Connections are supported
- 802.11 b/g/n and 802.15.4 (Option) wireless access point for B-Series Cordless Tools to connect as trailing spindles
- Includes a USB port, a plant network Ethernet port, a Spindle network Ethernet port, a Serial port, fieldbus options, and an emulated PLC function
- 24V DC I/O, 8 Inputs / 8 Outputs, assignable

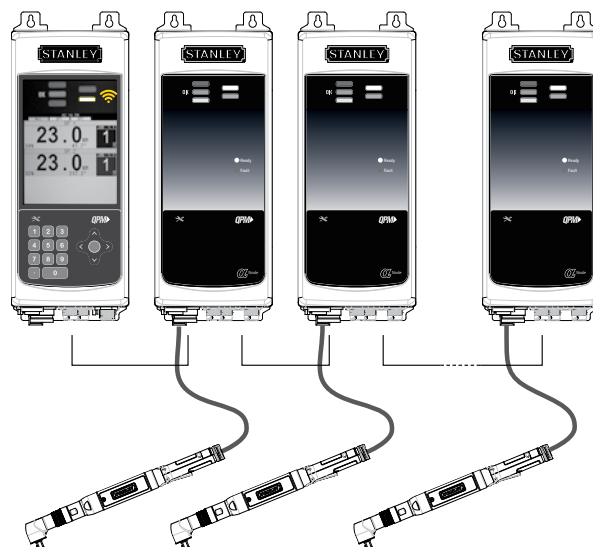

Spindles 1-24 connect using an isolated Ethernet Spindle Network

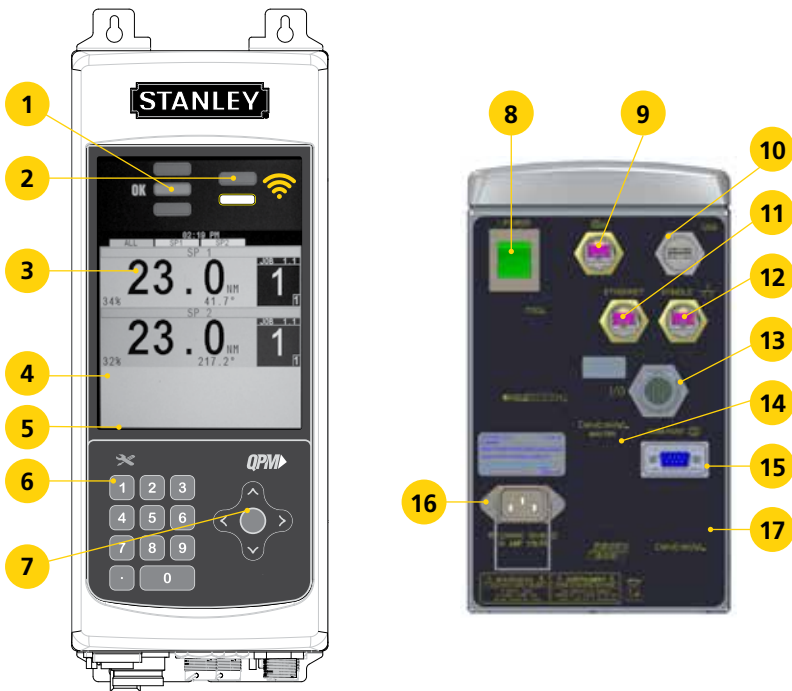

Description	
1	Red, Green, Yellow LEDs for Limits Evaluation
2	Programmable and Tool Ready LEDs
3	Touchscreen Color Display
4	Function Keys with Active Label Above
5	Maintenance Due Indicator
6	Numeric Keypad to Enter Numbers or Select Options
7	Cursor Keys with Center Button to Expand Lists
8	Power Switch
9	Alpha Toolbox Connector
10	USB Port for Data Transfer
11	Plant Network Ethernet Connector
12	Spindle Network Ethernet Connector
13	24V DC Input/Output Connector
14	Optional Master DeviceNet Connector
15	Serial Port Connector
16	Power Input
17	Optional Fieldbus Connector(s)

Standard Features	Serial	Ethernet	USB	24V DC I/O	Modbus/TCP	Alpha Toolbox
All Models	✓	✓	✓	✓	✓	✓

Note: M12 Ethernet port available upon request. Contact STANLEY for more details.

Alpha Model Number for Optional Features	DeviceNet	PROFIBUS	EtherNet/IP	PROFINET	GM Ports Lead	DeviceNet Available	M12 EtherNet/IP ports
QB5100-MGV				✓	✓	IEEE 802.11	
QB5100-MXV					✓	IEEE 802.11	
QB5100-XDV	✓					IEEE 802.11 b/g/n	
QB5100-XEV		✓					
QB5100-XGV				✓	✓	IEEE 802.11	
QB5100-XMV		✓				IEEE 802.11	✓
QB5100-XNV			✓			IEEE 802.11 b/g/n	
QB5100-XPV	✓						
QB5100-XXV					✓	IEEE 802.11	
QB5300-XXV					✓	IEEE 802.15.4	



QBE Advanced Controller



QBE Advanced Controller is a Single Spindle Controller or a Lead Controller for a Dual-Spindle System

BENEFITS:

- Color Display with Keypad
- Quick Set-up from the Controller Keypad, or with a PC through Ethernet
- Alpha Toolbox, STANLEY's web-based software for programming, collecting data and performing diagnostics
- Less training, less inventory and spare parts: STANLEY offers the same Controller platform for Cordless B-Series Battery Tools as well as Corded Handheld and Fixtured EB-Series, E-Series and EA-Series Tools

TECHNICAL FEATURES:

- Two-line color display and soft key keypad
- Operates as a Standalone Controller or as part of a dual spindle system
- The Advanced controller can control up to 2 spindles including its own (typically Nodes or Advanced controllers can be used)
- Stores Trace Data for 30,000 Fastening Cycles
- 255 jobs, 99 tasks, 12 steps including smart steps and all advanced strategies
- Includes a USB port and 2 Ethernet ports, a Serial port, fieldbus options, an integrated PLC
- 24V DC I/O, 8 Inputs / 8 Outputs, assignable



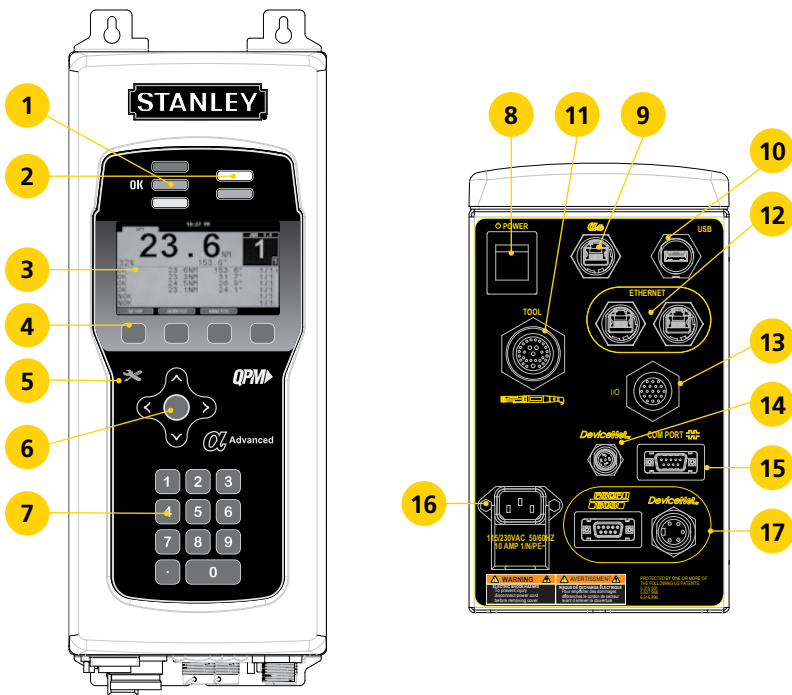

Description	
1	Red, Green, Yellow LEDs for Limits Evaluation
2	Programmable and Tool Ready LEDs
3	Display
4	Function Keys with Active Label Above
5	Maintenance Due Indicator
6	Numeric Keypad to Enter Numbers or Select Options
7	Cursor Keys with Center Button to Expand Lists
8	Power Switch
9	Alpha Toolbox Connector
10	USB Port for Data Transfer
11	Tool Connector
12	Plant / Spindle Network Ethernet Connectors
13	24V DC Input/Output Connector
14	Optional Master DeviceNet Connector
15	Serial Port Connector
16	Power Input
17	Optional Fieldbus Connector(s)

Standard Features	Serial	Ethernet	USB	24V DC I/O	Modbus/TCP	Alpha Toolbox
All Models	✓	✓	✓	✓	✓	✓

Note: M12 Ethernet port available upon request. Contact STANLEY for more details.

Alpha Model Number for Optional Features	DeviceNet	PROFIBUS	EtherNet/IP	PROFINET	GMP Ports	Lead DeviceNet Available	M12 EtherNet/IP ports
QB3101-MGV				✓		✓	
QB3101-MXV						✓	
QB3101-XDV	✓						
QB3101-XEV			✓				
QB3101-XGV				✓			
QB3101-XMV			✓				✓
QB3101-XNV				✓			
QB3101-XPV		✓					
QB3101-XXV							



QBE Standard Plus Controller



QBE Standard Plus Controller is a Single Spindle Controller

BENEFITS:

- Color Display with Keypad
- Economical, single Controller system option
- Quick Set-up from the Controller Keypad, or with a PC through Ethernet Alpha Toolbox, STANLEY’s web-based software for programming, collecting data and performing diagnostics
- Less training, less inventory and spare parts: STANLEY offers the same Controller platform for Cordless B-Series Battery Tools as well as Corded Handheld and Fixtured EB-Series, E-Series and EA-Series Tools

TECHNICAL FEATURES:

- Two-line color display and soft key keypad
- Operates as a Standalone Controller
- Stores Trace Data for 30,000 Fastening Cycles
- 255 jobs, 99 tasks, 12 steps including smart steps and all advanced strategies
- Includes a USB port and a Serial port
- 24V DC I/O, 8 Inputs / 8 Outputs, assignable

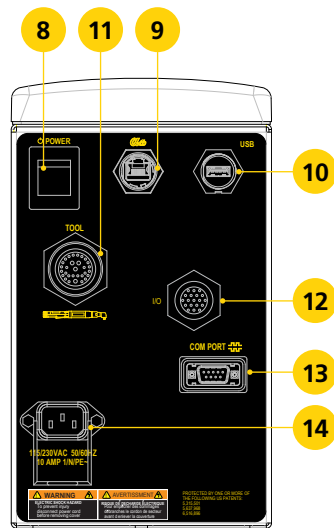
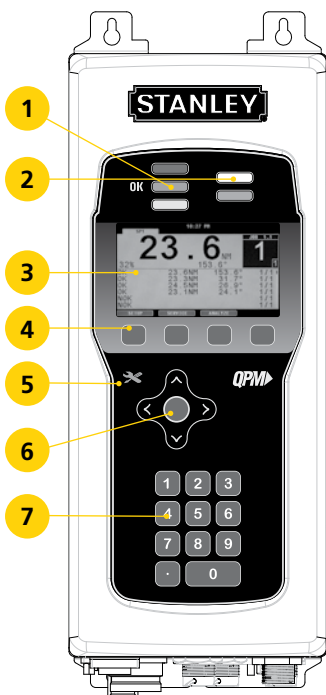

Alpha Model Number	Serial	Ethernet	USB	24V DC I/O	Modbus/TCF	Alpha Toolbox
QB2201	✓		✓	✓		✓

Description	
1	Red, Green, Yellow LEDs for Limits Evaluation
2	Programmable and Tool Ready LEDs
3	Display
4	Function Keys with Active Label Above
5	Maintenance Due Indicator
6	Cursor Keys with Center Button to Expand Lists
7	Numeric Keypad to Enter Numbers or Select Options
8	Power Switch
9	Alpha Toolbox Connector
10	USB Port for Data Transfer
11	Tool Connector
12	24V DC Input/Output Connector
13	Serial Port Connector
14	Power Input

QBE Node Controller



QBE Node Controller is a Single Spindle Controller used for trailing spindles in Multiple Tool (Fixtured) Applications

BENEFITS:

- Simplified user interface with LEDs
- Program through the USB port with Alpha Toolbox or through the Lead Controller
- Alpha Toolbox, STANLEY's web-based software for programming, collecting data and performing diagnostics
- Less training, less inventory and spare parts: STANLEY offers the same Controller platform for Cordless B-Series Battery Tools as well as Corded Handheld and Fixtured EB-Series, E-Series and EA-Series Tools

TECHNICAL FEATURES:

- No onscreen display, Red, Green, Yellow LEDs for Limits Evaluation, Tool Ready and Fault
- Operates as part of a multiple (fixtured) system
- Stores Trace Data for 30,000 Fastening Cycles
- 255 Jobs and 99 Tasks with 12 Steps
- 1 Serial ports and Ethernet Port for Spindle Network Connections

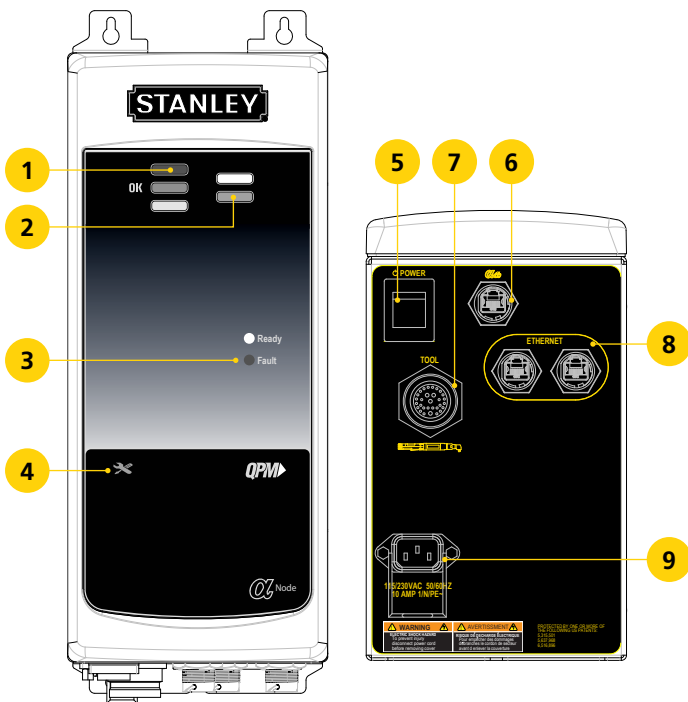

Alpha Model Number	Serial	Ethernet	USB	24V DC I/O	Modbus/TCP	Alpha Toolbox
QB0101		✓				✓

Description	
1	Red, Green, Yellow LEDs for Limits Evaluation
2	Programmable and Tool Ready LEDs
3	Ready / Fault LEDs
4	Maintenance Due Indicator
5	Power Switch
6	Alpha Toolbox Connector
7	Tool Connector
8	Spindle Network Ethernet Connectors
9	Power Input

QBE Network Node Controller



QBE Network Node Controller is a Cordless Tool Controller for up to 6 B-Series Cordless Tools

BENEFITS:

- Simplified user interface with LEDs
- Alpha Toolbox, STANLEY's web-based software for programming, collecting data and performing diagnostics
- Less training, less inventory and spare parts: STANLEY offers the same Controller platform for Cordless B-Series Battery Tools as well as Corded Handheld and Fixtured EB-Series, E-Series and EA-Series Tools

TECHNICAL FEATURES:

- No onscreen display, Red, Green, Yellow LEDs for Limits Evaluation, Tool Ready and Faults
- One-to-One wireless connection (802.15.4)
- Operates as an interface between the B-Series Cordless tools and customers' Error Proofing or Data Collection system
- Up to 6 B-Series Cordless Connections (802.11 b/g/n)
- Node controllers include an Ethernet port and a Serial port
- IEEE 802.15.4 wireless option communication to Network Node (QB0301)
- 24V DC I/O, 8 Inputs / 8 Outputs, assignable

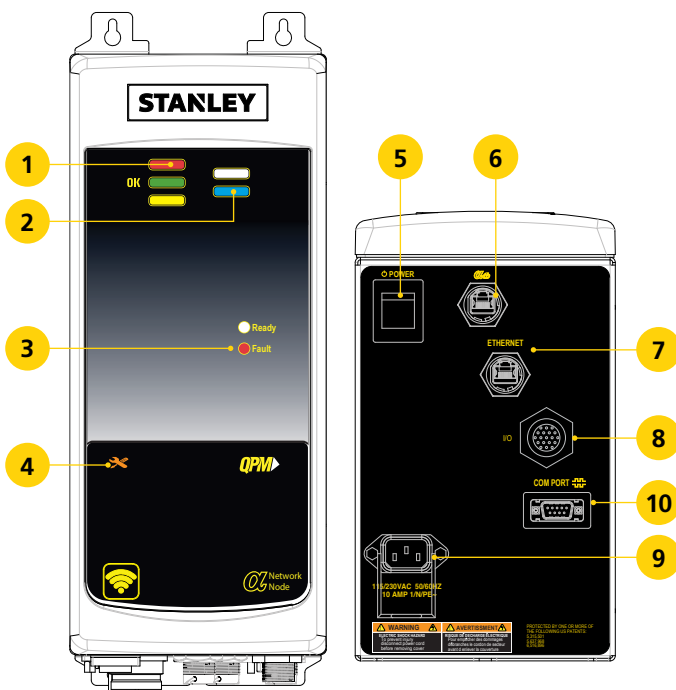

Alpha Model Number	Serial	Ethernet	USB	24VDC I/O	Modbus/TCP	Alpha Toolbox	
QB0201	✓	✓		✓	✓	✓	IEEE 802.11 b/g/n
QB0301	✓	✓		✓	✓	✓	IEEE 802.15.4

Description	
1	Red, Green, Yellow LEDs for Limits Evaluation
2	Programmable and Tool Ready LEDs
3	Ready / Fault LEDs
4	Maintenance Due Indicator
5	Power Switch
6	Alpha Toolbox Connector
7	Network Ethernet Connector
8	24V DC Input/Output Connector
9	Power Input
10	Serial Port Connector

QB Spindle Disconnect Controllers

Spindle Disconnect controllers are the same as the controllers on the previous pages with the exception they have a contactor inside to disconnect the 3-phases to the motor to stop the tool when activated. These controllers are designed to operate as part of a multiple (fixtured) system.

SPINDLE DISCONNECT

Connector on Bottom of Controller

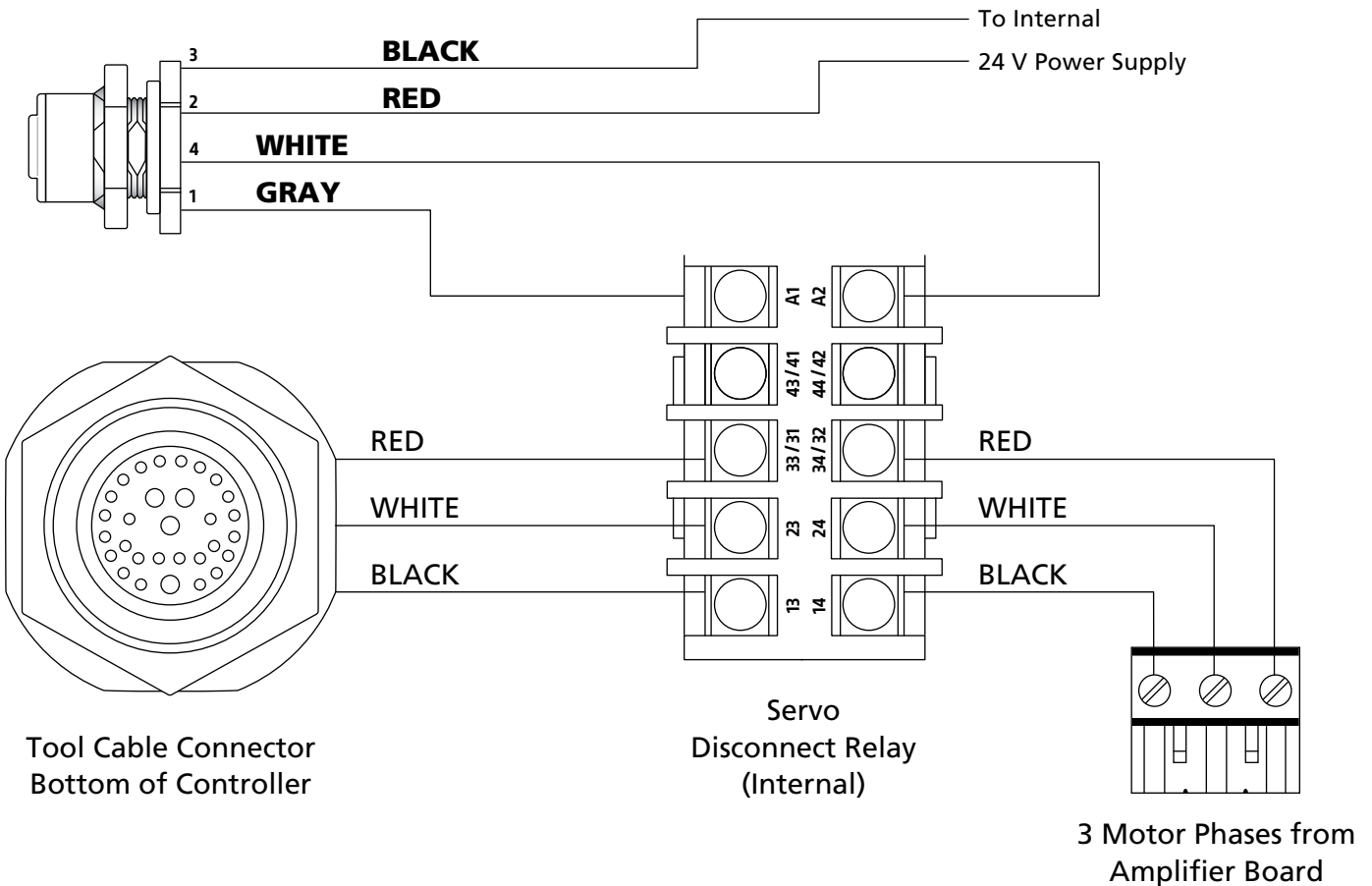

The controllers that have the Spindle Disconnect are the Expert, Advanced and Node. The model numbers will change from the previous pages. See chart.

Controller	Part No.
Node	QB0111
Advanced	QB3111-XXX
Expert	QB4111-XXX

If options for the controller are required, use the extensions from the appropriate controller page to add the proper extension. For instance, if Profibus is required on an Advanced controller use QB3111-XPV to get the Advanced controller with the Servo Disconnect and the Profibus fieldbus for the controller.

Accessories	Part No.
M12 Spindle Disconnect Tee	21R202205
M12 Spindle Disconnect Cable	21C102302

Alpha Toolbox Software

STANLEY Assembly Technologies – Alpha Toolbox Software for QBE Controllers

Alpha Toolbox, included in every QBE Controller, is used to program strategies, collect fastening cycle and trace data, and perform online diagnostics of the tool and controller. This powerful software utility enables:

- Tool configuration
- Tool diagnostics
- Data collection and maintenance intervals
- Advanced user integration

BENEFITS:

- No set-up is required
- Intuitive and Easy to Use
- Flexible Connectivity



QBE Controllers include a dedicated Alpha Toolbox port. This browser based software is executed from an Ethernet connection to the controller or wirelessly on a tablet, PC or phone. Simply connect a computer to the port, type "ATB.QPM" into a web browser and the software is available for use. The Wizard provided by STANLEY, offers an easy method to control programming directly from the keypad on the controller or with Alpha Toolbox. Users can also take advantage of advanced programming using Alpha Toolbox or Alpha Gateway software with a computer. For advanced, multiple tool systems, Alpha Toolbox includes a PLC Editor for easy integration.



AA-Series Tools

THE NEW AA SERIES PNEUMATIC NUTRUNNERS FROM STANLEY OFFERS AN INDUSTRY LEADING RANGE OF CLUTCH SHUT OFF TOOLS PROVIDING TOOL CHOICES THAT IMPROVE ASSEMBLY QUALITY, PRODUCTIVITY AND ERGONOMICS TO ENHANCE ASSEMBLY PROCESSES.

The adjustable clutch on the AA series nutrunners provides a high level of torque control for most general use applications. The tool's output torque is controlled by adjusting a mechanical spring that provides axial force on steel balls rolling between indented plates. By providing smooth disengagement at a preset torque while minimizing vibration to the operator, these tools are a great choice for fastening applications requiring torque values from 4.5 to 118 Nm.

The same trusted quality outputs as the STANLEY QPM DC tools are used on these AA clutch tools reducing costly complexity and end user spare parts needs. Gearless reverse selection method also reduces parts and complexity for improved Mean Time To Repair (MTTR) and Mean Time Between Failure (MTBF).

AA clutch tools have a free speed air consumption rate of 14.2 liters/second (30 cfm) at 90 PSI (6 Bar).



AA Series Pneumatic Tools conform to ISO standards 28927-2 and 15744 for noise and vibration. Actual vibration of AA23 and AA33 series tools is <math>< 2.5 \text{ m/sec}</math>. AA23 series tools' noise was measured at 79 dBA sound pressure levels. AA33 series tools' noise was measured at 85 dBA sound pressure levels. AA33 series tools' noise was measured at 96 dBA sound power level.

AA Angle Tools

4.5 to 118 Nm

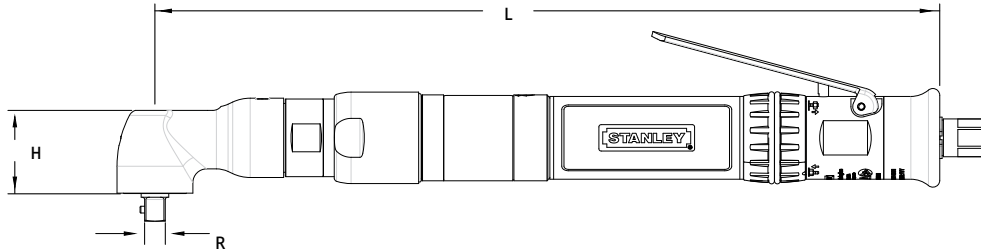

Model	Rated Speed		Max Torque		"R" Side to Center		"H" Head Height		"L" Length		Weight		Output
	RPM	Nm	lb ft	mm	in	mm	in	mm	in	kg	lb	Standard	
AA23LA14-9	1550	9	6.6	14	0.55	36	1.4	312.6	12.3	1.4	3.1	3/8" SD	
AA23LA13-14	1000	14	10.3	13	0.51	33	1.3	304.6	12.0	1.4	3.1		
AA23LA14-18	840	18	13.3	14	0.55	36	1.4	312.6	12.3	1.4	3.1		
AA33LA14-18	1110	18	13.3	14	0.55	36	1.4	352.2	13.9	1.6	3.6		
AA23LA14-22	665	22	16.2	14	0.55	36	1.4	312.6	12.3	1.6	3.5		
AA33LA14-25	790	25	18.4	14	0.55	36	1.4	352.2	13.9	1.6	3.6		
AA33LA14-28	500	28	20.7	14	0.55	36	1.4	352.2	13.9	1.6	3.6		
AA23LA18S-30	485	30	22.1	18	0.71	39	1.5	315.0	12.4	1.6	3.5		
AA33LA18S-40	500	40	29.5	18	0.71	39	1.5	354.8	14.0	1.7	3.9		
AA33LA18S-45	440	45	33.2	18	0.71	39	1.5	354.8	14.0	1.7	3.9		
AA33LA18S-50	390	50	36.9	18	0.71	39	1.5	354.8	14.0	1.7	3.9		

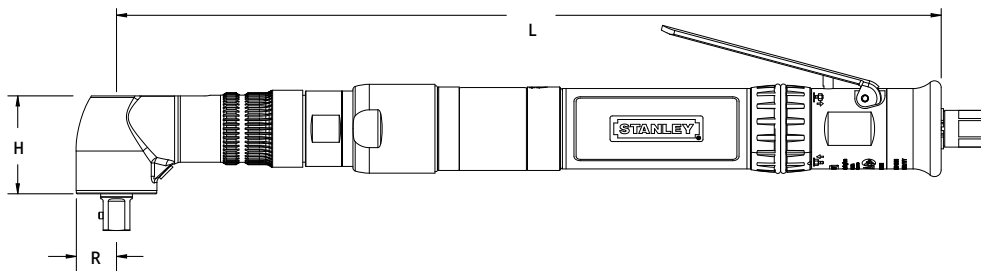

Model	Rated Speed		Max Torque		"R" Side to Center		"H" Head Height		"L" Length		Weight		Output
	RPM	Nm	lb ft	mm	in	mm	in	mm	in	kg	lb	Standard	
AA33LA19-59	335	59	43.5	19	0.75	46.4	1.8	390.8	15.4	2.1	4.6	1/2" SD	
AA33LA19-70	250	70	51.6	19	0.75	46.4	1.8	390.8	15.4	3.6	7.9		
AA33LA22A-106	180	106	78.2	22	0.87	47.9	1.9	474.8	18.7	2.9	6.5		
AA33LA22A-118	160	118	87	22	0.87	47.9	1.9	458.7	18.1	2.9	6.5		

AA Angle Tool Options

A13 Output	Part No.
3/8" Double-Ended	20D121912
Flush Socket	20D121914
1/4" Quick Change	20D121916
1/4" SD	20D121919
1/4" Magnetic Internal Hex	20D121920
A14 Output	Part No.
1/4" Internal Hex	20D112110
Flush Socket	20D112113
Flush Socket Rubber Cover	20S210000
A18S Output	Part No.
3/8" Double-Ended	20D136502
Flush Socket	20D136503
A19 Output	Part No.
Threaded Flush Socket	20D100021
A22 Output	Part No.
Flush Socket	20D100309
1/2" Double-Ended	20D100326
With Extension Support	20D100321
AA23 Handle	Part No.
NPT Air Inlet	20H103700
ISO Air Inlet	20H103701
AA33 Handle	Part No.
NPT Air Inlet	20H103800
ISO Air Inlet	20H103801
Socket Lock Pin	Part No.
Standard	20D227800
Rounded (Ball Detent)	20D227801
A19 / A22 Reaction Components	Part No.
Reaction Bar Assembly	20K100000
Mounting Flange	20K100300
Base Mount Bracket Assembly	20K100500
AA Tool Adjustment Screwdriver	20K401900

Suspension Bails

Output	Part No.
A13	20K101400
A14	20K101400
A18S	20K101400
A19	20K101400
A22	20K200000



Sockets and Accessories
begin on page 92

AA Inline Tools

5.5 to 54 Nm

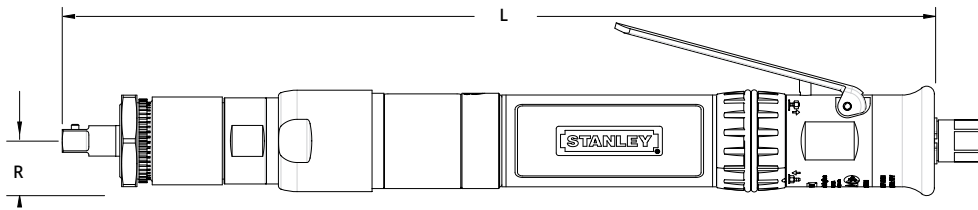

Model	Rated Speed		Max Torque		"R" Side to Center		"L" Length		Weight		Output	
	RPM	Nm	lb ft	mm	in	mm	in	kg	lb	Standard	Options	
AA23LB-11	1280	11	8.1	22.7	0.89	328.4	12.9	1.5	3.2	3/8" SD	1/4" QC	
AA23LB-15	990	15	11.1	22.7	0.89	322.4	12.7	1.5	3.2	3/8" SD	1/4" QC	
AA23LB-21	680	21	15.5	22.7	0.89	322.4	12.7	1.5	3.2	3/8" SD	N/A	
AA33LB-32	630	32	23.6	22.7	0.89	350.9	13.8	1.6	3.6	3/8" SD		
AA33LB-40	500	40	29.5	22.7	0.89	350.9	13.8	1.6	3.6	3/8" SD		
AA33LB-54	370	54	39.8	22.7	0.89	350.9	13.8	1.6	3.6	3/8" SD		

AA Inline Tool Options

Reaction Bar	Part No.
Reaction Bar, Aluminum	F3698
Reaction Bar, Steel	20K100100
Base Mount Bracket	A8606
Mounting Flange-B	20K101000
AA23 Handle	Part No.
NPT Air Inlet	20H103700
ISO Air Inlet	20H103701
AA33 Handle	Part No.
NPT Air Inlet	20H103800
ISO Air Inlet	20H103801
Socket Lock Pin	Part No.
Standard	20D227800
Rounded (Ball Detent)	20D227801
AA23 Handle	Part No.
NPT Air Inlet	20H103700
ISO Air Inlet	20H103701
AA Tool Adjustment Screwdriver	Part No.
	20K401900



Sockets and Accessories
begin on page 92

AA Hold & Drive Tools

14 to 110 Nm

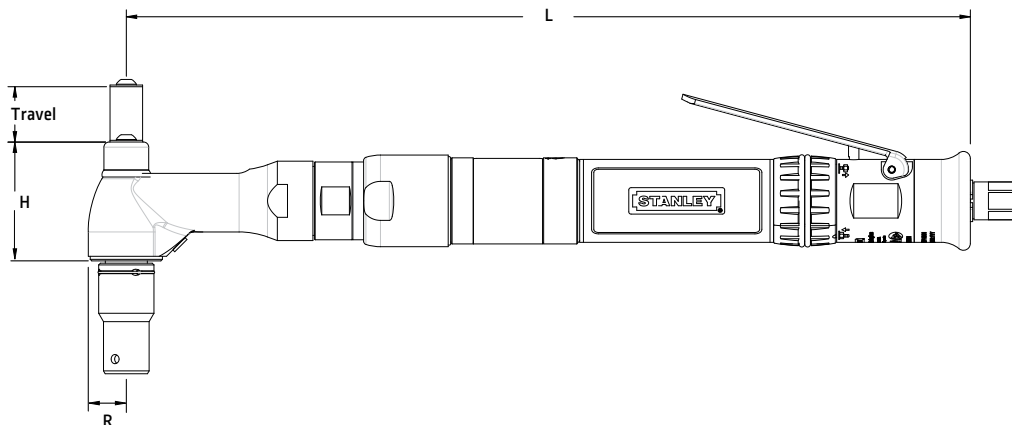

Model	Rated Speed		Max Torque		"R" Side to Center		"H" Head Height		"L" Length		Weight		Output
	RPM	Nm	lb ft	mm	in	mm	in	mm	in	kg	lb		
AA23LH18V1-28	485	28	20.7	18	0.71	131.9	5.2	341.7	13.5	1.8	4.0	25mm [1"]	
AA33LH18V1-46	343	46	33.9	18	0.71	131.9	5.2	387.8	15.3	1.9	4.18		
AA33LH22AV1-99	175	99	73	22	0.87	143.8	5.7	468.3	18.4	3.3	7.26		
AA33LH22AV1-110	141	110	81	22	0.87	143.8	5.7	468.3	18.4	3.3	7.26		
AA23LH18V2-28	485	28	20.7	18	0.71	190.3	7.5	341.7	13.5	1.8	4.0	50mm [2"]	
AA33LH18V2-46	343	46	33.9	18	0.71	190.3	7.5	387.8	15.3	1.9	4.18		
AA33LH22AV2-99	175	99	73	22	0.87	199.0	7.8	468.3	18.4	3.3	7.26		
AA33LH22AV2-110	141	110	81	22	0.87	199.0	7.8	468.3	18.4	3.3	7.26		

See pages 106-117 for the Hold and Drive Configuration Guide

Hold & Drive Options

A Tang holds the bolt while the nut is tightened

Typical Tang Options

- Female Torx
- Female Hex
- Rectangular

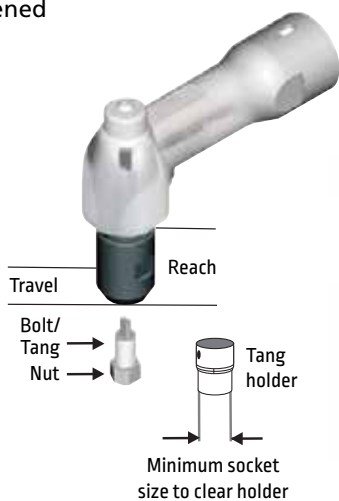

A Bit holds the bolt while the nut is tightened

Typical Tang Options

- Male Hex
- Male Torx

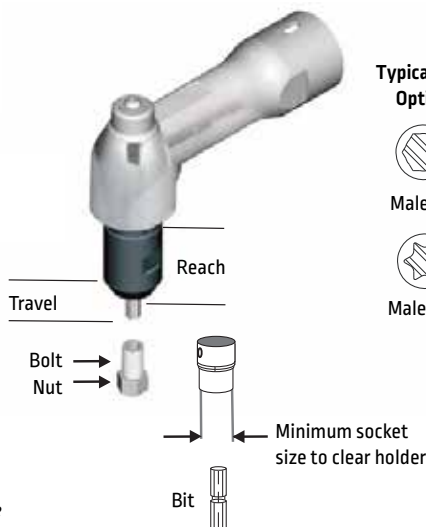

NOTE: The bolt can extend beyond the nut no more than the specified travel distance when tightened.

AA Hold & Drive Options

H18 Output	Part No.
Socket Options	20D905700
1" Travel Bit Holder Output	20D124600
2" Travel Bit Holder Output	20D124601
1" Travel Tang Holder Output	20D124602
2" Travel Tang Holder Output	20D124603
H18 Tang Holder	Part No.
Tang Holder Options	-20D905601
H18 Bit Holder	Part No.
Bit Holder Options	-20D905600
Suspension Bails	Part No.
Wire Bail	A3061
Swivel	20K101400
Standard	B3432
Mounting Flange-B	20K101000

H22 Output	Part No.
Socket Options	20D911000
1" Travel Tang Holder Output	20D103211
1" Travel Bit Holder Output	20D103212
2" Travel Tang Holder Output	20D103213
2" Travel Bit Holder Output	20D103214
H22 Tang Holder	Part No.
Tang Holder Options	-F4287
H22 Bit Holder	Part No.
Bit Holder Options	20D911100

AA23 Handle	Part No.
NPT Air Inlet	20H103700
ISO Air Inlet	20H103701
AA33 Handle	Part No.
NPT Air Inlet	20H103800
ISO Air Inlet	20H103801
Reaction Bar	Part No.
Reaction Bar Assembly	20K100000
Mounting Flange Assembly	20K100300
Base Mount Bracket Assembly	20K100500
Swivel Suspension Bails	Part No.
Non-Splined	20K101400
Splined	20K200000
AA Tool Adjustment Screwdriver	20K401900

AA Crowfoot Tools

6.5 to 70 Nm

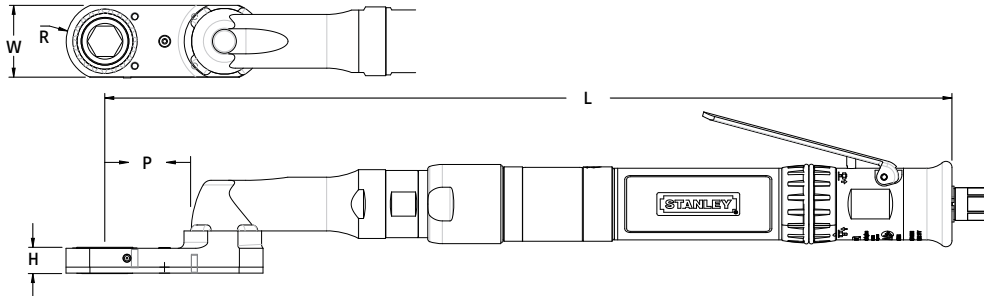

AA Crowfoot Tool Options

AA23 Handle	Part No.
NPT Air Inlet	20H103700
ISO Air Inlet	20H103701
AA33 Handle	Part No.
NPT Air Inlet	20H103800
ISO Air Inlet	20H103801
Reaction Bar	Part No.
Reaction Bar Assembly	20K100000
Mounting Flange Assembly	20K100300
Base Mount Bracket Assembly	20K100500
Swivel Suspension Balls	Part No.
Non-Splined Output	20K101400
Splined Output	20K200000
AA Tool Adjustment Screwdriver	20K401900

Model	Rated Speed	Max Torque		"R" Nose Radius		"T" Thickness		"W" Width		"P" Length		"L" Length		Weight		Maximum Hex Size	
	RPM	Nm	lb ft	mm	in	mm	in	mm	in	mm	in	mm	in	kg	lb	mm	in
AA23LC550-10	950	10	7.4	13	0.5	9	0.37	25	1	77	3.05	383.9	15.12	2.59	5.7	13	0.50
AA23LC106-13	745	13	9.6	12.7	0.50	16.2	0.64	25.4	1.00	64.6	2.50	370	14.6	1.6	3.5	13	0.50
AA23LC550-14	655	14	10.3	13	0.5	9	0.37	25	1	77	3.05	390.4	15.37	2.59	5.7	13	0.50
AA23LC8-14	745	14	10.3	13	0.5	16	0.64	25	1	45	1.76	364.4	14.35	1.72	3.8	13	0.50
AA23LC385-17	540	17	12.5	11.9	0.47	15.9	0.63	31.8	1.25	69.2	2.70	374	14.7	1.6	3.5	13	0.50
AA23LC308-19	505	19	14	13.5	0.53	20.6	0.81	31.8	1.25	70.2	2.80	376	14.8	2.7	5.95	13	0.50
AA23LC297-21	450	21	15.5	16.0	0.63	20.6	0.81	31.8	1.25	71.0	2.80	376	14.8	2.85	6.28	14	0.56
AA23LC66-21	450	21	15.5	16.0	0.63	21.3	0.84	31.8	1.25	28.5	1.10	333	13.1	2.81	6.2	14	0.56
AA23LC521-30	285	30	22.1	13.0	0.51	16.0	0.63	32.0	1.25	45.0	1.76	376	14.8	2.57	5.67	13	0.50
AA33LC362-25	470	25	18.4	13	0.5	16	0.63	26	1.02	66	2.59	473.9	18.66	2.69	5.94	13	0.50
AA33LC516-30	420	30	22.1	13.0	0.51	16.0	0.63	32.0	1.25	70.0	2.76	478	18.8	2.68	5.91	13	0.50
AA33LC29-31	390	31	22.9	21.0	0.81	14.0	0.55	38.1	1.50	43.0	1.70	348	13.7	2.4	5.3	19	0.75
AA33LC308-31	420	31	22.9	13.5	0.53	20.6	0.81	31.8	1.25	70.2	2.80	415	16.3	2.98	6.58	13	0.50
AA33LC297-35	370	35	25.8	16.0	0.63	20.6	0.81	31.8	1.25	71.0	2.80	376	14.8	3.13	6.91	14	0.56
AA33LC484-36	330	36	26.6	16	0.63	21	0.83	32	1.25	85	3.36	472	18.58	2.72	6	16	0.625
AA33LC66-40	325	40	29.5	16.0	0.63	21.3	0.84	31.8	1.25	28.5	1.10	354	13.9	3.1	6.83	14	0.56
AA33LC97-47	235	47	34.7	21.6	0.81	21.3	0.84	38.0	1.48	107	4.20	518	20.4	3.99	8.8	19	0.75
AA33LC506-50	235	50	36.9	33.0	1.30	17.0	0.68	66.0	2.60	52.0	2.03	407	16.0	3.59	7.92	38	1.50
AA33LC298-53	250	53	39.1	13.2	0.52	20.9	0.82	38.1	1.50	96.5	3.80	452	17.8	3.91	8.62	13	0.50
AA33LC187-54	170	54	39.8	21	0.81	15	0.58	38	1.5	102	4.03	601.7	23.69	2.72	6	19	0.75
AA33LC162-55	225	55	40.6	13.2	0.52	20.9	0.82	38.1	1.50	97.0	3.82	596	23.5	3.91	8.62	13	0.50
AA33LC499-58	210	58	42.8	13.2	0.52	16.5	0.65	38.0	1.48	155.0	6.10	510	20.1	3.99	8.8	13	0.50
AA33LC632-64	180	64	47.2	17	0.66	17	0.66	38	1.5	102.6	4.04	599.5	23.6	2.72	6	16	0.625
AA33LC31-70	170	70	51.6	20.6	0.81	27.9	1.10	38.1	1.50	38.9	1.50	514	20.2	3.8	8.4	19	0.75



Sockets and Accessories
begin on page 92

AA Repair Accessories

AA Tool Motor Service Kits

Descriptions	Part Number
AA23 Motor Housing Service Kit	20M103400
AA33 Motor Housing Service Kit	20M103401
AA23 Motor Service Parts <i>[Certified repair center only]</i>	20M103450
AA33 Motor Service Parts <i>[Certified repair center only]</i>	20M103451
AA22 / 33 Handle Rebuild Kit	20H104800
AA22 / 33 Clutch Service Kit	20G110400
AA22 / 33 Clutch Shut-Off Overhaul Kit	20G110600
AA22 / 33 Clutch Adjuster Overhaul Kit	20G110500

Each of these tools is required to repair the AA motor. It is recommended to buy the complete kit once then any one of the components as needed when they wear out.

AA Motor Repair Tools

Descriptions	Part Number
AA Motor Assembly / Disassembly Tool Kit <i>[contains 1-each of the parts below]</i>	20V102400
Motor Assembly Block	20V202001
Rear Bearing Press Tool	20V102300
Motor Bearing Removal Tool	20V202600
Motor Front Bearing Removal Tube	20V203200
Rear Bearing Removal Press Tool	20V201900
Motor Rear Bearing Removal Tube	20V203300

20V102400 AA Motor Repair Tool Kit Parts

Descriptions	Part Number
Throttle Seat Install Tool	20V102000
Throttle Lever Install Tool	20V102100
Rear Bearing Press Tool, AA2/3	20V102300
A13-19 Assembly Tool	20V200700
Clutch Cam Assembly Install Tool	20V201400
Rear Brg Removal Press Tool, AA2/3	20V201900
Motor Assembly Block, AA2/3	20V202001
Motor Bearing Removal Tool, AA2/3	20V202600
Throttle Seat Install Plug AA2/3	20V202800
Motor Front Bearing Removal Tube	20V203200
Motor Rear Bearing Removal Tube	20V203300
QPM #3 Gear Case To Angle Head Socket	20V204000

See AA Tool Manual for Use.

DC Electric Headlight Aim Tools

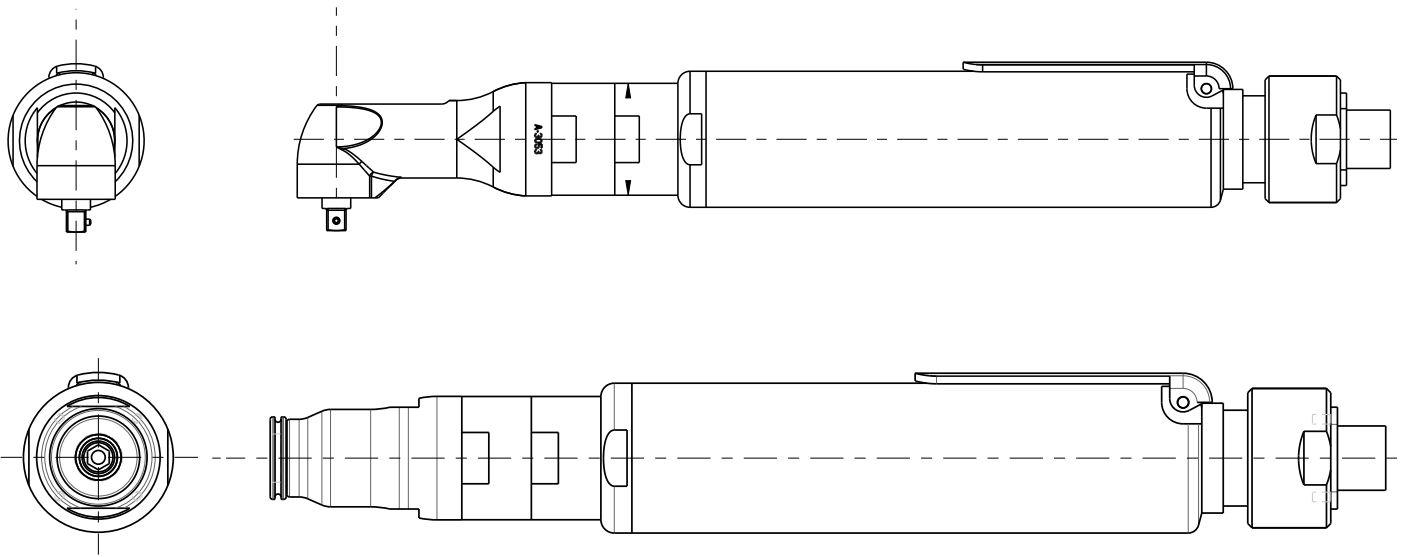

STANLEY offers durable tools for production headlight aiming systems with models that fit most alignment systems. In production, the operator typically positions one tool each on the horizontal and vertical adjusting screws. The headlight aiming system controls the direction and rotation of the tools to adjust the headlight.

Torque capacity, not critical to the application, ranges from 3 to 11 Nm (24 to 94 lb-in). Each tool includes the specified connector either on the tool end or specified system interface cable.

TOOL DURABILITY MINIMIZES PRODUCTION DOWN TIME

One-piece high strength T7075 aluminum housing as rugged as steel. Tool weighs 1.8 Kg (4 lb) excluding crowfoots.

A RANGE OF MODELS TO FIT YOUR SYSTEM

Connectors and pin-outs that fit different alignment systems. Straight, Right Angle and Crowfoot heads.

Model	Rated Speed	Cable Length		Connector	Drive	Output
	RPM	M	ft			Standard
S30-388	149	0	0	AMP 97-3102A-14S-6P[115]	1/4" SD	Right Angle
S30-390	224	0	0	AMP 97-3102A-14S-P[115]	1/4" Hex	Inline

Crowfoot outputs are available upon request.

Crowfoot/Tubenut Standard Sockets



A new part number system for standard crowfoot and tubenut sockets enables customers to describe and price standard sockets for each application. The part number includes information on head number of the tool, socket type, socket size and extension length. For special sockets or dimensions not included on this page, check the following pages or contact your local STANLEY sales representative.

CHOOSE YOUR SOCKET

STEP 1: Select the Base Code from the Head Number table

STEP 2: Add Type, Size & Extension separated by forward slashes

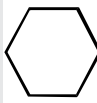
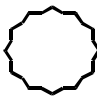
Note: Specify socket size no larger than Max Hex Size.

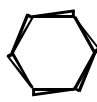
Crowfoot or Tubenut Head Number	Max Hex Size		Base Code	Type	Size		Length		Extension Code		
	(mm)	(in)			Size (mm)	Size Code	(mm)	(in)			
5, 10, 19, 31, 83, 126, 172, 406, 565, 586	19	3/4	L3217	SH Single Hex 	4	M4	1/8	2	Standard	Standard	0
7, 16, 39, 97, 299, 353, 552	19	3/4	L3258		5	M5	3/16	3	3	1/8	3
8, 106, 178, 311, 420, 445	13	1/2	L3224		6	M6	1/4	4	6	1/4	6
13, 230, 308, 333, 394, 443	13	1/2	L3213	DH Double Hex 	7	M7	5/16	5	9	3/8	9
20	27	1 1/16	L3255		8	M8	3/8	6	12	1/2	12
21, 98, 225, 284, 416	27	1 1/16	L3240		9	M9	7/16	7	15	5/8	15
23, 84, 95, 135, 309, 568	18	11/16	L3209	SD Surface Drive 	10	M10	1/2	8	18	3/4	18
29, 35, 121, 152, 175, 221, 234, 278, 287, 496	19	3/4	L3218		11	M11	9/16	9	21	7/8	21
32, 75, 91, 92, 132, 136, 137, 138, 147, 182, 184, 190, 202, 208, 209, 211, 212, 213, 266, 267, 300, 302, 303, 305	13	1/2	L3392 Thru Hex		12	M12	5/8	10	24	1	24
47, 170, 294	11	7/16	L3222	FL Fast Lead 	13	M13	11/16	11	27	1 1/16	27
69, 173, 279, 301, 307, 313, 317, 327, 362, 379, 381, 385, 448, 455, 477, 487, 516, 521	13	1/2	L3201		14	M14	3/4	12	30	1 1/8	30
74, 164, 261, 265, 269, 271, 273, 274, 286, 291, 312, 540	18	11/16	L3211		15	M15	13/16	13	33	1 1/4	33
79, 82, 103, 167, 508,	13	1/2	L3202	16	M16	7/8	14	36	1 3/8	36	
99, 116, 283, 285, 296	27	1 1/16	L3267	17	M17	15/16	15	39	1 1/2	39	
160, 550	13	1/2	L3228	18	M18	1	16	42	1 5/8	42	
200, 324, 396	19	3/4	L3220	19	M19	1 1/16	17	45	1 3/4	45	
203, 456	19	3/4	L3221	20	M20			48	1 7/8	48	
216	13	1/2	L3225	21	M21			51	2	51	
246, 297, 315,	13	9/16	L3256	22	M22						
252, 288, 346, 349, 387, 358, 408, 513	13	1/2	20D280700	23	M23						
264, 304	24	15/16	L3259	24	M24						
264, 304	24	15/16	L3260 Thru Hex	25	M25						

EXAMPLE ORDERS

Example 1: A #8 crowfoot head requires a 3/8 inch surface drive socket with a 1 inch extension. Select the BASE (L3224), TYPE (SD), SIZE (6) and EXTENSION (24).

Base	Type	Size	Ext.
L3224	/SD	/6	/24

Example 2: A #147 tubenut head requires a 10mm hex socket with a standard extension. Select the BASE (L3282), TYPE (SH), SIZE (M10) and EXTENSION (0).

Base	Type	Size	Ext.
L3282	/SH	/M10	/0

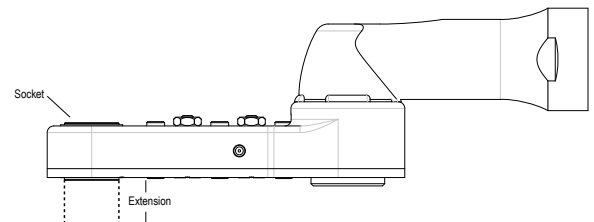

Crowfoot/Tubenut Special Sockets

CROWFOOT HEAD NUMBER(S) 8, 61, 106, 174, 178, 311, 420, 445

Use[s] Special Socket Option -A3729. Use the L3224 Base Socket, in the Standard Socket Configurator on page 116, to configure a standard socket.

Hex Socket

Size	Part No.	Feature
4mm	B3434	
4mm	F3129	Blind Socket
11/32"	A3682	
7/16"	F3116	both sides have Hex
7/16"	F3674	No Chamfer
7/16"	J3724	with Lead Chamfer
1/2"	F3172	Blind Socket
13mm	J3477	Double Hex with Groove

Extended Hex Socket

Size	Extension	Part No.	Feature
7/32"[5.5mm]	3mm	20D216402	Surface Drive
7/16"	1"	J3060	Surface Drive
3/8"	3/8"	A3749	
3/8"	1/2"	A3766	
9mm	3/4"	B3515	
10mm	3mm	J3197	
10mm	4mm	J3195	
10mm	5mm	J3196	
10mm	7mm	F3802	
10mm	10mm	B3569	with Retaining Ring
10mm	19mm	B3606	
1/2"	3mm	J3229	
1/2"	1/4"	B3164	both sides have Hex
1/2"	1/2"	J3169	
13mm	1/2"	A3976	
13mm	27mm	20D216404	

Hex Magnetic Socket

Size	Part No.	Feature
7mm	J3482	
10mm	B3172	
10mm	B3543	thru-hole
3/8"	B3895	Plugged
5/16"	A3690	Plugged
5/16"	A3951	Shallow, plugged
7/16"	A3696	Plugged
7/16"	F3863	thru-hole
11mm	F3181	Shallow, plugged
1/2"	A3705	
13mm	A3923	thru-hole

Extended Hex Magnetic Socket

Size	Extension	Part No.	Feature
1/4"	7.5mm	B3344	plugged
8mm	1/4"	20D243901	
8mm	1/4"	20D216401	shallow
8mm	15mm	B3508	plugged
8mm	3/8"	F3637	
8mm	3/8"	F3652	turned down diameter
7/16"	1/2"	A3928	
7/16"	1-1/4"	20D243900	
9mm	1/4"	20D216400	
3/8"	1/4"	B3866	
10mm	2mm	A6316	
10mm	1/4"	B3850	plugged
10mm	1/2"	F3664	Fast Lead
10mm	12mm	B3181	
11mm	12mm	B3222	
11mm	1/8"	B3167	plugged
13mm	1/4"	B3776	thru-hole
13mm	1/2"	J3360	

Male Square Drive

Size	Part No.	Feature
1/4"	B3823	
5/16"	J3261	with Retaining Ring
3/8"	F3242	
1/2"	20D216403	

Torx Socket

Size	Extension	Part No.
E5		L3191
E8	6mm	F3493

Extended Hex Magnetic Socket

Size	Extension	Part No.	Feature
1/4"		F3545	Use Customer's Bit
1/4"	1/4"	20D216405	Choose bit below

-F4296 - See Bits on page 172 [Step 6A]

Crowfoot/Tubenut Special Sockets

CROWFOOT HEAD NUMBER(S) 5, 10, 19, 31, 70, 83, 126, 406

Use[s] Special Socket Option -A4882. Use the L3217 Base Socket, in the Standard Socket Configurator on page 92, to configure a standard socket.

Hex Socket

Size	Part No.	Feature
8mm	L4655	
1/2"	B4257	
15mm	20D270202	Special C'Bore
18mm	L4003	thru broached with stop ring
19mm	B4511	Grooved
18mm	L4672	Part broached

Extended Hex Socket

Size	Extension	Part No.	Feature
15mm	3/8"	A4933	
5/8"	1/4"	B4069	Double Hex
11/16"	1/4"	B4133	1/2" Extension on opposite side
9/16"	1/4"	B4865	
19mm	2"	F4158	
5/8" [16mm]	35mm	F4379	
3/4"	1"	F4661	Extension on both sides
15mm	1/2"	F4933	
19mm	1-1/4"	J4383	with compression ring
15mm	1/4"	L4177	Fast Leat with Retaining Ring
17mm	1/4"	L4421	Extension on both sides
15mm	3/4"	20D270201	Surface Drive

TUBENUT HEAD NUMBER 20

Use[s] Special Socket Option -B4000. Use the L3255 Base Socket, in the Standard Socket Configurator on page 92, to configure a standard socket.

Hex Socket

Size	Part No.	Feature
7/8"	L4828	Broached
11/16"	B4301	
18mm	J4153	Broached
19mm	20D281800	19mm Slot
3/4"	B4771	Broached
21mm	A6214	
22mm	20D281801	19mm Slot
15/16"	B4269	Broached
1"	F4536	Broached
11/16"	B4270	Broached
11/16"	B4505	

J4572 Special Wire Twist Socket

Extended Hex Magnetic Socket

Size	Extension	Part No.
15mm	1/4"	B4039
19mm	1/2"	L4788

Male Square Drive

Size	Part No.	Feature
1/2"	S7542	
5/8"	20D116800	
1/2"	A6174	Wobble Square Drive

Torx Socket

Size	Part No.
E12	L4880
E18	A6172
E20	A6405

Internal Threaded Socket

Size	Pitch	Part No.
1/2"	20	F4519
3/4"	16	20D270200

20D116801 Insert Hex Socket

Size	Part No.
21mm	20D136000

Extended Hex Socket

Size	Extension	Part No.	Feature
3/4"	3/4"	J4557	
3/4"	3/4"	H4601	Broached
3/4"	3"	F4945	
22mm	15mm	N4264	
24mm	15mm	J4471	Broached
1"	1"	B4502	
42mm	5.3mm	L4136	

Dual Size Hex Socket

Size1	Size2	Part No.	Feature
19mm	26mm	L4836	
22mm	19mm	20D5200005	

CROWFOOT HEAD NUMBER(S) 13, 228, 230, 308, 333, 394, 443

Use[s] Special Socket Option -A4737. Use the L3213 Base Socket, in the Standard Socket Configurator on page 92, to configure a standard socket.

Extended Hex Socket

Size	Extension	Part No.	Feature
10mm	13mm	L3344	
13mm	5mm	B4616	
13mm	1/4"	B4148	
13mm	1/4"	F4486	3/8" Broach
13mm	10mm	B4577	
13mm	1/2"	B4196	
13mm	15mm	20D124102	
13mm	3/4"	J4903	
13mm	55mm	N4499	Surface Drive
1/2"	1/4"	B4383	
1/2"	3/8"	B4463	

Hex Socket

Size	Part No.	Feature
7mm	L3404	Triple Square
5/16"	J4561	With Groove
7/16"	20D124103	Without Ring Groove
7/16"	F4277	With Ball
1/2"	L4125	
1/2"	F4140	With Groove
13mm	J3477	Double Hex with Groove

Extended Hex Magnetic Socket

Size	Extension	Part No.
10mm	1/2"	L4636
10mm	15mm	20D124100
13mm	Standard	F4354
13mm	1/4"	L4805

Hex Magnetic Socket

Size	Part No.	Feature
10mm	20D124101	
13mm	N4941	
13mm	N4939	Double Hex

Male Square Drive

Size	Part No.	Feature
3/8"	J4312	
3/8"	L4612	Paint Marker Socket

Torx Socket

Size	Part No.
E10	20D241400
E12	H4896

Internal Threaded Socket

Size	Pitch	Part No.
1/2"	20	F4363

CROWFOOT HEAD NUMBER(S) 21, 98, 225, 284, 416

Use[s] Special Socket Option -A4949. Use the L3240 Base Socket, in the Standard Socket Configurator on page 92 to configure a standard socket.

Hex Socket

Size	Part No.	Feature
12mm	N4984	
15mm	N4761	
21mm	H4478	
21mm	N4227	Broached
30mm	L4889	
1 1/4"	L4302	Broached

Extended Hex Socket

Size	Extension	Part No.	Feature
19mm	3/8"	J4823	Surface Drive
19mm	1 1/4"	A6308	
22mm	54mm	B4923	
22mm	57mm	A6477	
22mm	2 1/8"	S7502	
23mm	1"	B4455	Extension is on both sides
24mm	3/4"	F4937	Fast Lead
1"	3/4"	B4963	
1 1/8"	2"	J4856	1/2" Below Through

Male Square Drive

Size	Part No.	Feature
1/2"	N4629	
5/8"	S9143	Wobble

Torx Socket

Size	Extension	Part No.
E18	15mm	20D245800
E20		H4818

Crowfoot/Tubenut Special Sockets

TUBENUT HEAD NUMBER(S) 23, 84, 95, 135, 309

Use[s] Special Socket Option -A4929. Use the L3209 Base Socket, in the Standard Socket Configurator on page 92 to configure a standard socket.

Hex Socket

Size	Part No.	Feature
5/16"	J4721	Broached
9/16"	H4160	
1/2"	H4256	
15mm	N4962	
17mm	F4325	Broached
18mm	N4376	Broached

Extended Hex Socket

Size	Extension	Part No.	Feature
5/8"	3/4"	J4645	
15mm	1/2"	F3303	Broached
15mm	13/4"	L4263	
16mm	1/2"	B4569	Broached
17mm	37mm	N4297	
18mm	1/2"	B4570	Broached

Male Square Drive

Size	Part No.	Feature
20mm	B3372	Both sides have male hex drive
20mm	B3726	

CROWFOOT HEAD NUMBER(S) 29, 35, 121, 152, 175, 221, 234, 278, 287, 496

Use[s] Special Socket Option -B4105. Use the L3218 Base Socket, in the Standard Socket Configurator on page 92 to configure a standard socket.

Hex Socket

Size	Part No.	Feature
1/4"	J4073	With Retaining Ring
5/16"	20D122602	With Retaining Ring
1/2"	F4863	
1/2"	F4408	With Ring Groove
1/2"	J4423	Double Hex
16mm	F4333	With Ring Groove
17mm	B4994	

Hex Magnetic Socket

Size	Part No.	Feature
10mm	20D122600	
13mm	A6100	
13mm	N4846	
13mm	H4167	
15mm	A6232	With Groove

Extended Hex Socket

Size	Extension	Part No.	Feature
1/4"	3/16"	F4875	With Groove
5/16"	5/8"	L4756	
13mm	13mm	20D238907	Special Outside Diameter
1/2"	3/4"	H4100	
14mm	1/4"	A6001	Extension is on both sides
9/16"	1/4"	B4185	
9/16"	5/16"	L4522	Fast Lead
9/16"	3/4"	A6412	
15mm	1/8"	F4941	
15mm	3/8"	B4754	
15mm	1/2"	L4620	1/2" Deep
15mm	85mm	A6224	
16mm	1/2"	L4014	
17mm	10mm	A6298	
18mm	13/4"	H4726	
18mm	2 1/4"	H4717	

Extended Hex Magnetic Socket

Size	Extension	Part No.	Feature
10mm	1/4"	H4878	
12mm	8mm	J4430	
12mm	8mm	H4735	
13mm	8mm	H4254	
13mm	1/4"	H4599	
13mm	15mm	A6442	
13mm	20mm	20D122603	11mm Bore
14mm	20mm	20D122601	
15mm	3/8"	J4274	
15mm	1/2"	H4211	

Male Square Drive

Size	Part No.	Feature
1/2"	A6088	

Internal Threaded Socket

Size	Part No.	Feature
1/2"	20	A6304

CROWFOOT HEAD NUMBER(S) 47, 170, 294

Use this list of special sockets only if the Standard Socket Configurator doesn't have the socket you need. Use[s] Special Socket Option -B3150. Use the L3222 Base Socket, in the Standard Socket Configurator on page 92 to configure a standard socket.

Hex Magnetic Socket

Size	Part No.	Feature
10mm	20D118100	
10mm	F3280	Double Hex
1/4"	F3521	Bit Holder

Extended Hex Magnetic Socket

Size	Extension	Part No.	Feature
10mm	10mm	F3458	Double Hex
10mm	3/16"	F3459	
10mm	11mm	J3111	Extension is on both sides
10mm	19mm	F3658	
10mm	21/2"	B3528	Extension is on both sides

CROWFOOT HEAD NUMBER(S) 69, 173, 279, 301, 307, 313, 317, 327, 362, 379, 381, 385, 448, 455, 477, 487, 516, 521

Use[s] Special Socket Option -B4750. Use the L3201 Base Socket, in the Standard Socket Configurator on page 92, to configure a standard socket.

Hex Socket

Size	Part No.	Feature
1/4"	A6401	With Retaining Ring
5/16"	20D242401	Double Square Socket

Hex Magnetic Socket

Size	Part No.	Feature
12mm	20D117601	Surface Drive
13mm	F4268	
13mm	20D117606	

Extended Hex Socket

Size	Extension	Part No.	Feature
5/16"	1/4"	20D117603	
10mm	10mm	20D242400	
10mm	15mm	20D117609	Surface Drive
13mm	1/8"	A6022	Oversize

Extended Hex Magnetic Socket

Size	Extension	Part No.	Feature
10mm	6mm	20D117604	
12mm	6mm	20D117605	
13mm	6mm	20D117600	
13mm	9mm	20D117602	Surface Drive
13mm	15mm	20D107900	
13mm	20mm	20D117607	Surface Drive

Male Square Drive

Size	Part No.
3/8"	H4212

Miscellaneous

Part No.	Feature
20D117608	12mm Hex Insert
20D135800	16mm Magnetic Socket with 12mm Hex Drive

Torx Socket

Size	Extension	Part No.
E12		20D242404
E12	15mm	A6431

Crowfoot/Tubenut Special Sockets

TUBENUT HEAD NUMBER(S) 74, 164, 261, 265, 269, 271, 273, 274, 286, 291, 312

Use[s] Special Socket Option -B3251. Use the L3211 Base Socket, in the Standard Socket Configurator on page 92 to configure a standard socket.

Hex Socket

Size	Part No.	Feature
12mm	20D243700	Broached Through
12mm	20D232900	
13mm	L3428	Surface Drive
13mm	F3277	Broached Flush
1/2"	F3092	Broached
14mm	20D243701	Broached Through
15mm	20D243704	Broached Through
16mm	A6376	Surface Drive
16mm	20D222500	Surface Drive
17mm	B3521	Broached Through
18mm	B3711	Broached Through

Extended Hex Socket

Size	Extension	Part No.	Feature
12mm	1/4"	20D230600	Extension on both sides
12mm	13mm	20D230300	Double Hex
13mm	1/4"	20D239100	
13mm	12mm	20D229200	
13mm	3/4"	20D238500	
5/8"	Standard	A6264	
9/16"	1/2"	A6265	
14mm	27mm	20D243702	Broached Through
16mm	5mm	A6271	
17mm	3mm	20D243705	6.5 Deep

CROWFOOT HEAD NUMBER(S) 79, 82, 103, 167, 508

Use[s] Special Socket Option -B4953. Use the L3202 Base Socket, in the Standard Socket Configurator on page 92 to configure a standard socket.

Hex Socket

Size	Part No.	Feature
13mm	B4984	Double Hex

Extended Hex Magnetic Socket

Size	Extension	Part No.	Feature
13mm	6mm	20D139100	Magnetic

Internal Threaded Socket

Size	Pitch	Feature
1/2"	20	20D238100

TUBENUT HEAD NUMBER(S) 99, 116, 283, 285, 296

Use[s] Special Socket Option -F4591. Use the L3267 Base Socket, in the Standard Socket Configurator on page 92 to configure a standard socket.

Hex Socket

Size	Part No.	Feature
19mm	L3099	8mm Deep
3/4"	F4621	Broached through
3/4"	L4680	Special Slot
13/16"	F4622	Broached through
21mm	20D267200	19mm Slot, 6mm Deep
22mm	H4925	Broached through
22mm	20D267204	19mm Slot
22mm	20D267202	Special Slot
7/8"	F4623	Broached through
15/16"	F4624	Broached through
24mm	J4567	22.5mm Slot
24mm	H4178	7mm Deep
1"	F4625	Broached through
11/16"	F4626	Broached through

Extended Hex Socket

Size	Extension	Part No.	Feature
19mm	10mm	20D246600	
20mm	3/8"	20D232800	
20mm	3/8"	20D216700	
21mm	40mm	N4702	Broached through
22mm	105mm	20D237900	
7/8"	1/4"	N4497	Double Hex
7/8"	1/2"	J4733	
7/8"	1"	N4381	
7/8"	1"	H4141	
7/8"	13/8"	N4363	Fast Lead
7/8"	2 5/8"	H4102	
24mm	20mm	J3896	36mm Diameter
30mm	45mm	J3895	

J4455 Special Socket For Turnbuckle

TUBENUT HEAD NUMBER(S) 147, 32, 75, 91, 92, 132, 136, 137, 138, 182, 184, 190, 202, 208, 209, 211, 212, 213, 266, 267, 270, 288, 300, 302, 303, 305

Use[s] Special Socket Option -F3577. Use the L3281, L3282, L3283, or L3392 Base Socket, in the Standard Socket Configurator on page 92 to configure a standard socket.

Hex Socket

Size	Part No.	Feature
8mm	J3297	
9mm	J3296	
3/8"	A6027	
10mm	F3861	
10.4mm	20D255000	
11mm	J3018	
11mm	J3362	Double Hex
7/16"	H4219	
12mm	J3486	
13mm	F3577	
13mm	A6213	Double Hex
13mm	F3689	Double Hex
13mm	F3946	Surface Drive
1/2"	H4701	

Extended Hex Socket

Size	Extension	Part No.	Feature
8mm	5mm	J3784	
3/8"	1/4"	H4718	
10mm	1/4"	J3674	
10mm	10mm	H4496	
10mm	12mm	L3312	Surface Drive
11mm	5mm	J3456	
11mm	8mm	H4530	
11mm	10mm	J3019	
11mm	10mm	L3378	Double Hex
11mm	15mm	J3361	
11mm	15mm	J3680	
7/16"	3/8"	H4440	
7/16"	15mm	H4788	
12mm	3mm	L3143	
12mm	5mm	L3109	
12mm	5mm	J3501	Double Hex
12mm	10mm	L3110	
12mm	15mm	L3111	
13mm	6mm	L3422	
13mm	6mm	L3423	Surface Drive
13mm	7mm	L3359	
13mm	3/8"	L3374	
13mm	10mm	L3411	Double Hex

CROWFOOT HEAD NUMBER 160

Use[s] Special Socket Option -F3812. Use the L3228 Base Socket, in the Standard Socket Configurator on page 92 to configure a standard socket.

Extended Hex Magnetic Socket

Size	Extension	Part No.	Feature
10mm	3/4"	J3265	

Torx Socket

Size	Extension	Part No.
E10		20D215600
E10	5mm	20D215601

CROWFOOT HEAD NUMBER(S) 200, 324, 396

Use[s] Special Socket Option -N4774. Use the L3220 Base Socket, in the Standard Socket Configurator on page 116 to configure a standard socket.

Hex Socket

Size	Part No.
15mm	N4774

CROWFOOT HEAD NUMBER 216

Use[s] Special Socket Option -H4086. Use the L3225 Base Socket, in the Standard Socket Configurator on page 116 to configure a standard socket.

Male Hex Drive

Size	Part No.	Feature
1/2"	20D248400	

Crowfoot/Tubenut Special Sockets

CROWFOOT HEAD NUMBER(S) 203, 456

Use[s] Special Socket Option -N4864. Use the L3221 Base Socket, in the Standard Socket Configurator on page 92, to configure a standard socket.

Extended Hex Socket

Size	Extension	Part No.	Feature
13mm	Standard	20D213302	.312 Deep

Torx Magnetic Socket

Size	Part No.	Feature
T-50	20mm	20S111300

Extended Hex Magnetic Socket

Size	Extension	Part No.	Feature
10mm	Standard	20D213303	
13mm	Standard	20D213301	

CROWFOOT HEAD NUMBER(S) 246, 297, 315

Use[s] Special Socket Option -H4648. Use the L3256 Base Socket, in the Standard Socket Configurator on page 92, to configure a standard socket.

Hex Magnetic Socket

Size	Part No.	Feature
13mm	20D114700	
13mm	20D114704	5.3mm Deep

Extended Hex Socket

Size	Extension	Part No.	Feature
8mm	6mm	20D230004	Double Hex, Special O.D.
10mm	36mm	20D230001	45mm Extension on other side
12mm	6mm	20D114706	Magnetic
13mm	1/4"	20D114705	Magnetic
13mm	1/4"	H4763	Magnetic
13mm	1/4"	A6078	Magnetic
9/16"	3/8"	A6314	Double Hex

TUBENUT HEAD NUMBER(S) 252, 346, 349, 387, 358, 408, 513

Use[s] Special Socket Option -L3130. Use the 20D280700, L3233 Base Socket, in the Standard Socket Configurator on page 92, to configure a standard socket.

Hex Socket

Size	Part No.	Feature
11mm	20D245408	5.3mm Deep
13mm	20D245405	Surface Drive
13mm	20D245406	1/4" Deep, Surface Drive, Thick Wall
13mm	20D245407	1/4" Deep, Thick Wall
13mm	20S211100	1/4" Deep, Surface Drive
13mm	20S211101	1/4" Deep

Extended Hex Socket

Size	Extension	Part No.	Feature
12mm	9mm	20S213500	.312 Deep
14mm	2mm	20D245400	

TUBENUT HEAD NUMBER(S) 264, 304

Use[s] Special Socket Option -F3888. Use the L3259, L3260 Base Socket, in the Standard Socket Configurator on page 116, to configure a standard socket.

Hex Socket

Size	Part No.	Feature
15mm	L3405	
18mm	20D281200	5/16" Deep
24mm	L3347	1/2" Deep

Extended Hex Socket

Size	Extension	Part No.	Feature
13mm	Standard	L3412	
3/4"	3/4"	L3005	
13/16"	1"	F3461	
7/8"	1"	H4012	

CROWFOOT HEAD NUMBER(S) 7, 16, 299, 306, 353

Use this list of special sockets only if the Standard Socket Configurator on page 116 doesn't have the socket you need.

Use(s) Special Socket Option -A4690. Use the L3258 Base Socket, in the Standard Socket Configurator on page 92, to configure a standard socket.

Hex Socket

Size	Extension	Part No.	Feature
13mm		20D111300	
5/16"		A6395	
14mm		20D118801	Drive Insert
17mm		L4049	
17mm	62mm	B4047	

Torx Bit

Size	Extension	Part No.
T30		A6341
T30	20mm	20D240609
T40		A6373
T45		20D240600
T45	20mm	20D240610
T50		A6403

Hex Bit

Size	Extension	Part No.	Feature
3/16"		A6179	
1/4"		A5668	
3/8"		A5666	
5mm		F4380	
6mm		F4399	
6mm		A6206	Square Bit
6mm	5mm	A6207	
7mm		F4296	
8mm		F4513	
10mm		L4259	
14mm		A5724	

Special Bit

Size	Extension	Part No.
XNZ		H4533
Slotted		20D246700

5/16" Bit Holder 20D118800 with Bit Retainer Clip

Flush Angle Standard Sockets





A new part number system for standard flush angle head sockets enables customers to describe and price standard sockets for each application. The part number includes information on head number of the tool, socket type, socket size and extension length. For special sockets or dimensions not included on this page, check the following pages or contact your local STANLEY sales representative.

CHOOSE YOUR SOCKET

STEP 1: Select the Base Code from the Head Number table

STEP 2: Add Type, Size & Extension separated by forward slashes

Note: Specify socket size no larger than Max Hex Size.

Flush Angle Head Number DTU	Max Hex Size		Base Code	Type	Size		Size		Length		Extension Code
	[mm]	[in]			Size [mm]	Size Code	Size [in]	Size Code	[mm]	[in]	
A15 (as in EB33LA15-27)	13	1/2	20D283200	SH Single Hex 	4	M4	1/8	2	Standard	Standard	0
A18	16	5/8	20D213505		5	M5	3/16	3	3	1/8	3
A19	17	5/8	20D222300		6	M6	1/4	4	6	1/4	6
A22	19	3/4	L3270	DH Double Hex 	7	M7	5/16	5	9	3/8	9
A26	22	7/8	L3435		8	M8	3/8	6	12	1/2	12
					9	M9	7/16	7	15	5/8	15
				SD Surface Drive 	10	M10	1/2	8	18	3/4	18
					11	M11	9/16	9	21	7/8	21
					12	M12	5/8	10	24	1	24
				FL Fast Lead 	13	M13	11/16	11	27	1 1/16	27
					14	M14	3/4	12	30	1 1/8	30
					15	M15	13/16	13	33	1 1/4	33
					16	M16	7/8	14	36	1 3/8	36
					17	M17	15/16	15	39	1 1/2	39
					18	M18	1	16	42	1 5/8	42
					19	M19	1 1/16	17	45	1 3/4	45
					20	M20			48	1 7/8	48
					21	M21			51	2	51
					22	M22					
					23	M23					
					24	M24					
					25	M25					
					26	M26					
					27	M27					

EXAMPLE ORDER

Example: An A19 flush angle head requires a 3/8 in surface drive socket with a 1 in extension. Select the BASE (20D222300), TYPE (SD), SIZE (6) and EXTENSION (24).

Base	Type	Size	Ext.
20D222300	/SD	/6	/24

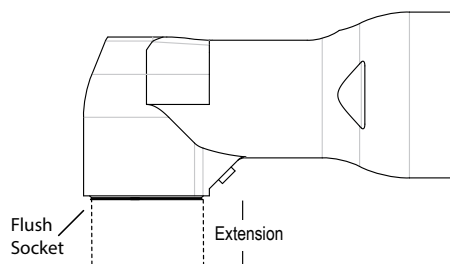

Flush Angle Special Socket Selection

~B3686 SOCKET OPTIONS FOR A13 FLUSH OUTPUT 20D121914

Maximum Hex size for this output is 12mm. *B3686 is the default socket unless another is specified on Purchase Order. Use this list of special sockets only if the Standard Socket Configurator on page 102 doesn't have the socket you need.

Hex Socket

Size	Part No.	Feature
4mm	B3834	
7mm	B3686*	
1/4"	B3751	
5/16" [8mm]	B3752	
5/16" [8mm]	20D126500	With Retaining Ring
3/8"	B3753	
10mm	B3754	

Extended Hex Socket

Size	Extension	Part No.
8mm	1/4"	J3041
5/16" [8mm]	1/16"	J3706
10mm	5mm	20D253204
10mm	10mm	20D253200
10mm	3/4"	20D238300
10mm	1/2"	J3100

Hex Magnetic Socket

Size	Part No.
5/16" [8mm]	J3823
10mm	L3393

Extended Hex Magnetic Socket

Size	Extension	Part No.
5/16" [8mm]	1/2"	20D126501
10mm	1/4"	L3073

Double Hex Socket

Size	Part No.
8mm	L3154
10mm	20D253205

Double Hex Magnetic Socket

Size	Part No.
10mm	20D126503

Torx Socket

Size	Part No.
E10	20D253202

~20D905800 SOCKET OPTIONS FOR A14 FLUSH OUTPUT 20D112113

Maximum Hex size for this output is 13mm. *20D255500 is the default socket unless another is specified on Purchase Order.

Surface Drive Socket

Size	Part No.
10mm	20D255505
12mm	20D255500*
13mm	20D255501

Extended Surface Drive Socket

Size	Extension	Part No.
10mm	10mm	20D255503
12mm	1/4"	20D255506
13mm	1/4"	20D255508
13mm	9mm	20D255507

Extended Surface Drive Thin Wall Socket

Size	Extension	Part No.
13mm	1/4"	20D126406

Includes 20D236604 Compression Ring to prevent cracking

Surface Drive Magnetic Socket

Size	Part No.
10mm	20D126402
12mm	20D126400
13mm	20D126401

Extended Surface Drive Magnetic Socket

Size	Extension	Part No.
10mm	10mm	20D126405
13mm	9mm	20D126404

Flush Angle Special Socket Selection

~20D901200 SOCKET OPTIONS FOR A18 FLUSH OUTPUT 20D136503

* F4747 is the default socket unless another is specified on Purchase Order.

Hex Socket

Size	Part No.	Feature
6mm	20D213504	
5/16" (8mm)	L4653	with Retaining Ring
3/8"	20D213501	
10mm	F4897	
7/16"	F4896	
11mm	F4898	
12mm	L4006	
1/2"	F4895	
13mm	F4899	
13mm	L4543	1/2" clearance hole
9/16"	F4747*	
14mm	20D213500	
15mm	F4900	
15mm	N4769	with Retaining Ring
5/8" (16mm)	F4894	

Extended Hex Socket

Size	Extension	Part No.	Feature
10mm	3mm	N4638	
10mm	7mm	N4251	
10mm	8mm	20D213503	
10mm	1"	J4979	
12mm	1/4"	L4839	
13mm	1/8"	N4086	
13mm	1/4"	N4918	
13mm	12mm	H4494	
13mm	1/2"	L4435	
13mm	1"	J4444	
9/16"	1/4"	J4413	
14mm	1/4"	N4268	
14mm	16mm	J4311	
15mm	1/4"	L4378	
15mm	1/4"	N4686	with Retaining Ring
15mm	3/8"	H4459	
15mm	1/2"	J4684	
15mm	1/2"	20D213502	Surface Drive
16mm	1/4"	N4312	
16mm	150mm	N4343	
17mm	5mm	H4301	
17mm	20mm	A6192	

Surface Drive Socket

Size	Part No.
13mm	L4022

Extended Surface Drive Socket

Size	Extension	Part No.
3/8"	10mm	H4236
13mm	5mm	L4935
13mm	10mm	L4934
14mm	30mm	H4371
16mm	1/4"	N4581

Hex Magnetic Socket

Size	Part No.
13mm	L4834

Extended Hex Magnetic Socket

Size	Extension	Part No.
10mm]	8mm	20D118202
11mm	5/8"	L4509
12mm	3mm	A6309
13mm	1/2"	H4921
13mm	23mm	20D118200
15mm	3/8"	A6115

Torx Socket

Size	Part No.
E8	H4367

Torx Socket

Size	Part No.
5mm	X4048
6mm	X4047
8mm	X4091
10mm	X4093
T30	X4198
T40	X4248
T50	X4249

~20D903900 SOCKET OPTIONS FOR A19 (THREADED) FLUSH OUTPUT 20D100021 AND A19 (SPLINED) FLUSH OUTPUT 20D100106

Use this list of special sockets only if the Standard Socket Configurator doesn't have the socket you need. Use the 20D222300 Base Socket, in the Standard Socket Configurator on page 102 to configure a standard socket.

Hex Socket

Size	Part No.
9/16"	20D222305
18mm	20D222308

Extended Hex Socket

Size	Extension	Part No.
17mm	6mm	20D118003
18mm]	12mm	20D118001

Extended Hex Magnetic Socket

Size	Extension	Part No.
18mm]	12mm	20D118002

Torx Bit

Size	Extension	Part No.
T30		A6341
T30	20mm	20D240609
T40		A6373
T45		20D240600
T45	20mm	20D240610
T50		A6403

~20D902700 SOCKET OPTIONS FOR A22 FLUSH OUTPUT 20D100309

Use the 20D115100 Base Socket, in the Standard Socket Configurator on page 126 to configure a standard socket.

TORX SOCKET

Size	Part No.
E18	20D268400

~A5107 SOCKET OPTIONS FOR A32 FLUSH OUTPUT 20D102201

Size	Part No.
17mm	20D267300
18mm	A5651
19mm	A5248
3/4" Square	A5479
21mm	A5175
22mm	A5112
22mm Fast Lead	A5183

Size	Part No.
23mm	20D267303
24mm	A5107
24mm Fast Lead	A5380
24mm Surface Drive	A5438
1"	A5113
1" Fast Lead	A5473
27mm	A5114

~20D904000 Bit Options for 5/16" Bit Holder 20D118000 with Bit Retainer Clip

Choose Bit

Size	Extension	Part No.	Feature
3/16"		A6179	
1/4"		A5668	
3/8"		A5666	
5mm		F4380	
6mm		F4399	
6mm		A6206	Square Bit
6mm	5mm	A6207	
7mm		F4296	
8mm		F4513	
10mm		L4259	
14mm		A5724	

Miscellaneous Bits

Size	Extension	Part No.
XNZ		H4533
Slotted		20D246700

~20D903700 SOCKET OPTIONS FOR A26 FLUSH OUTPUT 20D100409

Use the 20D116600 Base Socket, in the Standard Socket Configurator on page 126 to configure a standard socket.

Size	Extension	Part No.
17mm	1/4"	20D267301
21mm	1/2"	A6234
24mm	8mm	A5261
24mm	1/2"	A6428
24mm Surface Drive	1/2"	20D267302
24mm	15mm	A5129
27mm	2.5mm	A5238
27mm	20mm	A5574

H18, 22, 26 & 32 Bit Holder Configuration Guide

STEP 1: Choose Type of Hold & Drive (See page 107 for Tang Holder)

STEP 2: Choose Hold & Drive travel length

- » Option 1: LH18V1= 1 inch of travel
- » Option 2: LH18V2= 2 inch of travel

Requires LH18V1 for $\leq 26\text{mm}$
Requires LH18V2 for $\geq 26\text{mm}$ & $\leq 52\text{mm}$

STEP 3: Choose Socket (Step 3 on pages 108, 109, 112 or 114)

STEP 4: Choose Bit Holder (Step 4A on pages 108, 109, 113 or 114)

STEP 5: Determine extension length required (Use images below to determine the required socket and/or bit holder extension length) Add socket extension up to, but not over, the bolt threads — the socket should not extend over the threads.

STEP 6: Choose Bit (Step 6A on page 128, 131, 133 or 135)

Bit protrusion

Bit flush

Bit recessed

Socket	Bit Holder	Bit
20D253602	20D254200	N4991

Example: An H18 hold and drive requires a 14 mm hex socket extended 5 mm with a 1/4" bit holder (standard extension) and an 8 mm Hex bit.

$$\text{Bit Protrusion (mm)} = 18\text{mm} + \text{Bit Holder Extension (mm)} - \text{Socket Extension (mm)}$$

If you choose a 20D253602 socket, 20D254200 bit holder and a N4991 bit, the bit will protrude 13 mm from the bottom of the socket. The bit will protrude 13 mm because a standard length bit holder was chosen with a 5mm extended socket.

$$13\text{mm Bit Protrusion} = 18\text{mm} + 0\text{mm Bit Holder Extension} - 5\text{mm Socket Extension}$$

H18, 22, 26 & 32 Tang Holder Configuration Guide

STEP 1: Choose Type of Hold & Drive (See page 106 for Bit Holder)

STEP 2: Choose Hold & Drive travel length
 » Option 1: LH18V1= 1 inch of travel
 » Option 2: LH18V2= 2 inch of travel

STEP 3: Choose Socket
 (Step 3 on pages 108, 109, 112 or 114)

STEP 4: Choose Tang Holder
 (Step 4B on pages 108, 110, 111, 113 or 114)

Note: Standard Length Socket & Bit Holder Shown

Requires LH18V1 for <= 26mm
 Requires LH18V2 for >= 26mm & <= 52mm

Tang
 Bolt
 Nut

STEP 5: Determine extension length required (Use images below to determine the required socket and/or tang holder extension length)

Add socket extension if tang is longer than 11.5mm, but never extend the socket past the bottom of the tang.

Tang Flush for:
 Bit Holder Length = Std
 Socket Extension = Std

Tang Recessed for:
 Bit Holder Length = Std
 Socket Extension > Std

Tang Holder Depth = 11.5 mm

Tang Flush

Tang Recessed

Socket	Tang Holder
20D253602	20D261703

Example: An H18 hold and drive requires a 14 mm hex socket extended 5 mm, with a 6 mm hex tang holder standard extension.

Tang Recessed (mm) = Socket Extension (mm) – Tang Holder Extension (mm)

If you choose a 20D253602 socket and a 20D261703 tang holder, the tang holder will be recessed 5 mm. The tang will be recessed because a standard length tang holder was chosen with a 5mm extended socket.

5mm Tang Recessed = 5 mm Socket Extension – 0 mm Tang Holder Extension

H18 Output Options

▶ **STEP 1:** Choose type of hold & drive:

Option A: Bit Holder See page 106 for config. guide

Option B: Tang Holder See page 107 for config. guide

▶ **STEP 2:** Choose Hold & Drive travel length — reference EB tool sections for available model number: EB non-fixtured tools, page 11, EB fixtured tools, page 31.

▶ **STEP 3:** Choose standard socket size of one of the below types:

~20D905700 SOCKET OPTIONS

Hex

Size	Part No.
13mm	20D5201001
14mm	20D253600
15mm	20D253604
16mm	20D253601

Size	Part No.
17mm	20D253603
18mm	20D253606
19mm	20D253610
24mm	20D253611

Hex Surface Drive

Size	Part No.
17mm	20D253612

Extended Hex

Size	Extension	Part No.
14mm	5mm	20D253602
14mm	6mm	20D253605
16mm	17mm	20D253607

▶ **STEP 4A:** Choose standard bit holder size:

~20D905600 BIT HOLDER OPTIONS

Size	Part No.
1/4"	20D254200
5/16"	20D253400

▶ **STEP 4B:** Choose tang holder size:

~20D905601 TANG OPTIONS

Size	Part No.
5mm x 10.3mm	20D261701
5mm x 9.5mm	20D5201000
5.5mm	20D261706

Size	Part No.
6mm	20D261703
6mm x 10mm	20D261700

Size	Part No.
6mm x 11mm	20D261702
10mm	20D261705

▶ **STEP 5A:** Determine socket and/or bit holder extension length required. Calculate the bit protrusion using the following equation: Bit Protrusion (mm) = 18 mm + Bit Holder Extension (mm) – Socket Extension (mm)

▶ **STEP 5B:** Determine socket and/or tang holder extension length required. Calculate the tang recession using the following equation: Tang Recessed (mm) = Socket Extension (mm) – Tang Holder Extension (mm)

▶ **STEP 6A:** Choose bit:

~F4296 BIT SELECTION

Description	Part No.
T45 HEX BIT, FOR 5/16" BH	20D240600
T30 HEX BIT, FOR 1/4" BH	20D240601
HEX BIT 5/16 - 8MM X 25mm LG	20D240603
9MM HEX BIT, FOR 1/4" BH	20D240605
5/16" HEX BIT, FOR 7/16" BH	20D240606
T-30 BIT, SPCL LENGTH, 5/16 HLD R EXT 20MM OUT OF HOLDER	20D240609
T-45 BIT, SPCL LENGTH, 5/16 HLD R EXT 20MM OUT OF HOLDER	20D240610
6MM HEX BIT, FOR 1/4" BH	20D240611
T55 BIT 5/16" HEX	20D240613
HEX BIT T40, 1/4 HOLD x1LG	20D240615
40IP X 5/16" HEX BIT	20D240616
30IP X 5/16" HEX BIT	20D240617
45IP FOR 5/16" B.H.	20D240618
HEX BIT 5/16, 8MM W/ SPCL FLAT	20D240619
5MM X 5MM EXT BIT, 5/16 BH	20D240902
5MM X 12.5MM X 5MM EXT BIT 5/16 BH	20D240903

Description	Part No.
6MM X 5MM EXT BIT 5/16 BH	20D240904
SLOTTED BIT, FOR 5/16" BH	20D246700
21MM X 20MM DP, HEX SKT 40A2H	20D5200018
5MM HEX BIT, SHORT, 5/16" BH	20D5200700
6MM HEX BIT, SHORT, 5/16" BH	20D5200701
T40 BIT, SHORT, 5/16" BH	20D5200702
3/8" HEX BIT, FOR 5/16" BH	A5666
1/4" HEX BIT, FOR 5/16" BH	A5668
14MM HEX BIT, FOR 7/16" BH	A5724
T27 TORX BIT, FOR 1/4" BH	A6134
5/32" HEX BIT, FOR 1/4" BH	A6178
3/16" HEX BIT, FOR 5/16" BH	A6179
6MM SQ BIT, FOR 5/16" BH	A6206
6MM X 5MM BIT, FOR 5/16" BH	A6207
T30 HEX BIT, FOR 5/16" BH	A6341
T40 HEX BIT, FOR 5/16" BH	A6373

Description	Part No.
T50 HEX BIT, FOR 5/16" BH	A6403
1/4 HEX BIT, FOR 1/4" BH	A6453
7MM HEX BIT, FOR 5/16" BH	F4296
5MM HEX BIT, FOR 1/4" BH	F4361
5MM HEX BIT, FOR 5/16" BH	F4380
6MM HEX BIT, FOR 5/16" BH	F4399
8MM HEX BIT, FOR 5/16" BH	F4513
SOCKET 14MM X 15MM EXT.	H4223
T15 TORX BIT, FOR 1/4" BH	H4280
SLOTTED BIT, FOR 1/4" BH	H4436
XNZ SCREW BIT, FOR 5/16" BH	H4533
7MM HEX BIT, FOR 1/4" BH	H4909
7/8 HEX SOCKET	J4850
10MM HEX BIT, FOR 5/16" BH	L4259
5/16" HEX BIT, FOR 1/4" BH	N4451
8MM HEX BIT, FOR 1/4" BH	N4991

H22 Output Options

► **STEP 1:** Choose type of hold & drive:

Option A: Bit Holder See page 106 for config. guide

Option B: Tang Holder See page 107 for config. guide

► **STEP 2:** Choose Hold & Drive travel length — reference EB tool sections for available model number: EB non-fixtured tools, page 11, EB fixtured tools, page 31.

► **STEP 3:** Choose standard socket size of one of the below types:

20D911000 SOCKET OPTIONS

Use the 20D288400 Base Socket, in the Standard Socket Configurator, on page 136, to configure a standard socket.

Hex

Size	Part No.
7/16"	A6184
7/8"	A6186
13mm [1/2"]	A6185
14mm	H4747
9/16	N4884
15mm	N4665
16mm [5/8"]	N4617
1"	20S202000
27mm	20D232607

Extended Hex

Size	Extension	Part No.
14mm	1-5/8"	A6451
14mm	2-5/8"	20D215100
14mm	4-5/8"	20D215101
14mm	7-3/8"	20D215102
15mm	1/2"	H4597
15mm	1"	A6282
15mm	6"	A6002
16mm	3/8"	20D245502
16mm	17mm	20D245503
16mm	30mm	N4620
16mm	60mm	20D245500
16mm	200mm	20D245501
19mm	11mm	20D215106
21mm	67.6mm	20D222006
21mm	110mm	20D132204
21mm	6"	20D222600
24mm	1/2"	20D222903

Deep Extended Hex

Size	Extension	Part No.
18mm	18mm	H4038
21mm	18mm	H4037

Surface Drive Extended Hex

Size	Extension	Part No.
18mm	46mm	H4500
18mm	12-1/2"	20D132203
21mm	40mm	20D222001
21mm	80mm	20D222000

Hex Surface Drive

Size	Part No.
13mm	H4435
15mm	A6200

Extension Tube Options with Hex Sockets

Size	Extension	Part No.
18mm	8"	20D132201
18mm	12"	20D132200
19mm	4"	20D132202

► **STEP 4A:** Choose standard bit holder size:

20D911100 SPECIAL BIT HOLDER OPTIONS

Size	Extension	Part No.
5/16"		57750 (Special Diameter)
5/16"	100mm	20D5200009
5/16"	110mm	20D132306
5/16"	4"	20D132302
5/16"	150mm	20D215208
5/16"	155mm	20D215207
5/16"	175mm	20D247200
5/16"	6 5/8"	20D215202
7/16"		20D215201

► **STEP 4B:** See next page to choose tang holder size

H22 Output Options continued

► STEP 4B: Choose tang holder size:

~F4287 TANG OPTIONS

Description	Part No.	Description	Part No.	Description	Part No.
H22 SKT/EXT TUBE KIT, 19mm, 4"	20D132202	10MM FEM.HEX TANG HOLDER	F4406	10MM FAST LEAD TANG HOLDER	H4877
TANG/EXTENSION KIT,8MMHX,12"LG	20D132300	7.7 X 9.8 X 16MM EXT TANG HOLD	F4542	6.35MM X 8.0MM TANG HOLD 3/8" E	H4883
8MM X 8" EXT H22 TANG ASM	20D132301	5MM X 8MM TANG HOLDER	F4544	8MM HEX TANGHOLDER 8" EXT	H4888
8MM X 12-1/2" EXT, SURF DR H22	20D132305	5.7MM X 8MM TANG HOLDER	F4572	TANG HOLDER 9.4 X 11.3MM STD EX	H4889
TANG HOLDER 11MM SURF. DR X STD	20D214300	8MM (5/16) INT. HEX TANG HOLDER	F4573	8.0 X 10.5MM TANG HOLDER, 8" EX	H4904
TANG HOLDER 8MM SURF. DR. X STD	20D214301	5.9MM X 8.1MM TANG HOLDER	F4596	8.7 X 11MM TANG OLDER, STD. EXT	H4905
6MM HEX 6MM DEEP, TANG H22	20D214303	10MM X 13MM TANG HOLDER	F4600	10.2 X 11.5MM TANG HOLDER, STD	H4906
13MM HEX TANG HOLDER, A22/40A4H	20D214304	8.5 HEX FEMALE TANG HOLDER	F4636	TANG HOLDER 8MM X 10MM 1-1/8 EX	H4958
7.2MM X 10MM, 11MM EXT TANG	20D214305	.390" X .529" TANG HOLDER	F4673	10MM HEX TANG HOLD 32MM EXT	H4960
TANG HOLDER 6.4MM X 8.4M X STD'	20D215400	8MM X 6.35MM TANG HOLDER	F4718	10MM TANG HOLD LEFT HAND FAST L	J4043
10MM FEMALE HEX x 6.00" EXTENDED	20D222700	2.7MM X 7MM BIT	F4866	1/4 X 5/16 TANG HOLDER	J4178
10.22mm FEMALE HEX TANG HOLDER	20D222702	6.7MM X 7MM TANG HOLDER	F4870	8MM X 6.35 X 1/2 TANG HOLDER	J4214
10.5mm STD EXT, SH, TANG HOLDER	20D222705	7.2MM X 10.2MM TANG HOLDER	F4975	8.5 X 10.5 X 16MM TANG HOLDER	J4296
A3H TANG HOLDER, 8.8MM X 9.8MM	20D226100	6.3MM X 9.3MM TANG HOLDER	H4115	8.5 X 10.5MM TANG HOLDER	J4302
6.5MM X 8MM, TAPERED LEAD, TANG HOLDER, A3H/H22	20D226101	7MM HEX TANG HOLDER 1" EXT	H4161	9.75 X 12MM TANG HOLDER	J4314
E8 TORX TANG HOLDER, A2H/A3H/A4	20D226200	8MM X 11MM TANG HOLDER W/ LEAD	H4176	7.7 X 9.8 X 80MM TANG HOLDER	J4315
TANG HOLDER, E12 TORX	20D226201	8MM SQ FEMALE TANG HOLDER	H4191	7.7 X 9.8 X 157MM TANG HOLDER	J4317
E8 TORX X 6" EXT HEX BIT	20D226202	6 X 10MM TANG HOLDER .600 OD	H4209	8MM HEX TANG HOLDER 10MM EXT	J4382
E8 TORX TANG HOLDER SPCL Ø	20D226203	.340 HEX TANG HOLDER	H4210	8MM HEX TANG HOLDER	J4456
TANG HOLDER 5.0 X 6.3MM	20D242700	8MM HEX TANG HOLDER 1" EXT	H4372	7MM FEMALE HEX TANG HOLDER	J4586
5.5 X 7.3, 6MM EXT, TANG HOLDER	20D242701	TORX SOCKET TX3114	H4373	6.3 X 9MM TANG HOLDER	J4707
6.0MM X 5.0 MM, TANG HOLDER	20D242702	9.2 X 12.5MM TANG HOLDER	H4448	8MM X 11MM TANG HOLDER	J4785
TANG HOLDER 5.4mm X 7.7mm	20D242703	4MM X 6MM TANG HOLDER	H4475	8MM X 5.7MM X 1" EXT TANG HOLDE	J4830
10MM X 32MM EXT, SURF DR TANG	20D245103	9.2 X 12.5MM TANG HOLDER 182MM	H4483	6.3 X 7.5MM TANG HOLDER	J4877
10MM X 37MM, SURF DR, TANG HLDR (H22)	20D245105	9.22 X 12.5MM TANG HOLD 155MM E	H4484	8.90 X 11.20MM X 80MM TANG HOLD	J4990
10MM X 37MM EXT., TANG HOLDER (H22)	20D245106	9.2 X 12.5MM TANG HOLDER 10MM E	H4485	9MM FEMALE HEX TANG HOLDER	L4005
10MM X 67.6MM EXT, HEX, TANG HOLDER H22	20D245109	8 X 10MM TANG HOLDER 10MM EXT	H4488	10MM X 6MM TANG HOLDER	L4017
10mm HEX, 64mm O'ALL LENGTH	20D245111	6.3 X 8.7MM TANG HOLDER 80MM EX	H4489	5MM X 8MM TANG HOLDER	L4019
10MM X 55MM OAL TANG H22/H26	20D245112	9MM HEX TANG HOLDER 46MM EXT	H4499	11/32 HEX FEMALE TANGE HOLDER 3	L4106
5MM X 12.5MM TANG HOLDER	20D245114	6 X 8MM TANG HOLDER 43MM EXT	H4577	8.2MM X 9.8MM TANG HOLDER	L4117
TORX SOCKET 3/8 SQ. DR X E12 X .65 OD	20D245115	9 X 11MM TANG HOLDER	H4578	3/8 FEMALE HEX TANG HOLDER	L4373
8MM DOUBLE HEX TANG HOLDER	20D245116	6 X 8MM TANG HOLDER 47MM EXT	H4593	9.2 X 12.5MM TANG HOLDER 80MM E	L4523
TANG HOLDER - 7MM SURF DR	20D246900	5.7 X 8MM TANG HOLDER 5MM EXT	H4606	8MM X 5.77MM TANG HOLDER 36MM E	L4524
TANG HLDR ASSY, H22, 5/16/8MM, SH STD. EXT. SOCKET 6" DRIVE EXT.	20DS200045	5.6 X 9.8MM TANG HOLDER	H4607	6MM X 7.72MM TANG HOLDER	L4544
TANG HOLDER SP. 11.28 DOUBLE HE	20S200602	5.9 X 6.8MM TANG HOLDER	H4676	6 X 8MM TANG HOLDER	L4644
15MM X 17MM TANG HOLDER	20S201900	6.8 X 8.25MM TANG HOLDER	H4725	TANG HOLDER 9MM SURF DR	L4694
7MM FEMALE TANG HOLDER 6" EXT	A6003	2 STEP TANG HOLD 6.00&7.08 X 8	H4748	TANG HOLDER 12.5 X 9.2 X 300MM	L4732
4.4 X 8MM TANG HOLDER	A6005	7MM X 11MM TANG HOLDER	H4761	TANG HOLDER 12.5 X 9.2 MM	L4738
6MM X 8MM TANG HOLDER	A6089	TANG HOLDER 9.2MMX12.5MMX45MM	H4819	TANG HOLDER 8MM HEX 80 MM EXT	L4784
6.24 X 7.5MM TANG HOLDER	A6136	7.3MM X 9.4MM TANG HOLDER	H4829	11MM HEX TANG HOLDER	L4803
8MM SQ TANG HOLDER 47MM EXT	A6226	5.7MM X 8MM TANG HOLDER	H4840	8MM HEX TANG HOLDER X 19 MM EXT	L4848
10MM HEX X 75MM EXT TANG HOLDER	A6233	5 X 7.5MM TANG HOLDER	H4857	TANG HOLDER 8.2 X 9.8 MM 80MM E	L4869
7.7MM X 9.8MM FEMALE SHANK HOLD	F4287	6.35 X 8.12MM TANG HOLDER	H4858	4MM MALE HEX TANG HOLDER	L4898
1/4" HEX HOLDER	F4360	12MM FEMALE HEX TANG HOLDER	H4874	6.3 X 9.8MM TANG HOLDER	L4978

H22 Output Options continued

~F4287 TANG OPTIONS

Description	Part No.	Description	Part No.	Description	Part No.
TANG HOLDER 12.5 X 9MM X 70MM E	N4029	8 X 5.7 TANG HOLDER 87MM EXT	N4400	TANG HOLDER 9 X 11.5MM X 80MM E	N4747
TANG HOLDER 12.5 X 9MM X 145MM	N4030	6.3 X 8.0 X 32MM EXT TANG HOLDE	N4413	TANG HOLDER 9 X 12.6MM X 157MM	N4748
TANG HOLDER 12.5 X 9	N4031	9.2 X 12.5MM TANG HOLDER 8.5MM	N4467	TANG HOLDER 8 X 10MM X 80MM EXT	N4749
TANG HOLDER 12.5 X 9MM X 75MM E	N4032	9.2MM X 12.5MM X 26.5MM EXT. SK	N4469	TANG HOLDER 8 X 10MM X 157MM EX	N4752
TANG HOLDER 10 X 7.6MM X 75MM E	N4033	8MM X 12MM TANG HOLDER	N4483	5MM HEX TANG HOLDER	N4758
14MM DOUBLE HEX SOCKET	N4064	6MM X 13MM TANG HOLDER	N4484	1/4" X 7/16" TANG HOLDER	N4826
12.5MM X 9MM TANG HOLDER 32MM E	N4130	10MM HEX T HOLDER 1/4" EXT FAST	N4575	6.3MM X 9.8MM TANG HOLDER 37MM	N4834
12.5MM X 9MM TANG HOLDER 27MM EX	N4131	7.2MM X 9.2MM TANG HOLDER 80MM	N4587	10MM X 7MM TANG HOLDER	N4921
12.5MM X 9MM TANG HOLDER 102MM	N4132	7.7MM X 9.8MM X 30MM EXT.TANG.H	N4621	11/32" HEX TANG HOLDER 1-1/2" E	N4927
10MM X 7.6MM TANG HOLDER 32MM E	N4133	7.2MM X 9.2MM TANG HOLDER (A3H)	N4658	10MM X 7.6MM TANG HOLDER	N4994
9.2 X 12.5MM TANG HOLDER 157MM	N4151	8MM X 6MM TANG HOLDER	N4666	10MM X 7.3MM TANG HOLDER 152MM	N4995
12.5 X 9MM TANG HOLDER 62MM EXT	N4187	10 X 7.6MM TANG HOLDER 182MM EX	N4697	TORX SOCKET 3/8" SQ X E14 DRIVE	R7927
TANG HOLDER 10MM HEX X 1.531 EX	N4189	10 X 7.6MM TANG HOLDER 102MM EX	N4699	E12 TORX SOCKET	R8461
TANG HOLDER 6MM HEX	N4192	10MM X 3-1/8 EXT TANG HOLDER	N4712		
12.5MM X 9MM TANG HOLDER 52MM E	N4384	6MM HEX TANG HOLDER 80MM EXT	N4716		

▶ **STEP 5A:** Determine socket and/or bit holder extension length required. Calculate the bit protrusion using the following equation:
 Bit Protrusion (mm) = 18 mm + Bit Holder Extension (mm) – Socket Extension (mm)

▶ **STEP 5B:** Determine socket and/or tang holder extension length required. Calculate the tang recession using the following equation: Tang Recessed (mm) = Socket Extension (mm) – Tang Holder Extension (mm)

▶ **STEP 6A:** Choose bit:
 ~F4296 BIT SELECTION

Description	Part No.	Description	Part No.	Description	Part No.
T45 HEX BIT, FOR 5/16" BH	20D240600	6MM X 5MM EXT BIT 5/16" BH	20D240904	T50 HEX BIT, FOR 5/16" BH	A6403
T30 HEX BIT, FOR 1/4" BH	20D240601	SLOTTED BIT, FOR 5/16" BH	20D246700	1/4 HEX BIT, FOR 1/4" BH	A6453
HEX BIT 5/16 - 8MM X 25mm LG	20D240603	21MM X 20MM DP, HEX SKT 40A2H	20DS200018	7MM HEX BIT, FOR 5/16" BH	F4296
9MM HEX BIT, FOR 1/4" BH	20D240605	5MM HEX BIT, SHORT, 5/16" BH	20DS200700	5MM HEX BIT, FOR 1/4" BH	F4361
5/16" HEX BIT, FOR 7/16" BH	20D240606	6MM HEX BIT, SHORT, 5/16" BH	20DS200701	5MM HEX BIT, FOR 5/16" BH	F4380
T-30 BIT, SPCL LENGTH, 5/16 HLDR EXT 20MM OUT OF HOLDER	20D240609	T40 BIT, SHORT, 5/16" BH	20DS200702	6MM HEX BIT, FOR 5/16" BH	F4399
T-45 BIT, SPCL LENGTH, 5/16 HLDR EXT 20MM OUT OF HOLDER	20D240610	3/8" HEX BIT, FOR 5/16" BH	A5666	8MM HEX BIT, FOR 5/16" BH	F4513
6MM HEX BIT, FOR 1/4" BH	20D240611	1/4" HEX BIT, FOR 5/16" BH	A5668	SOCKET 14MM X 15MM EXT.	H4223
T55 BIT 5/16" HEX	20D240613	14MM HEX BIT, FOR 7/16" BH	A5724	T15 TORX BIT, FOR 1/4" BH	H4280
HEX BIT T40, 1/4 HOLD x 1LG	20D240615	T27 TORX BIT, FOR 1/4" BH	A6134	SLOTTED BIT, FOR 1/4" BH	H4436
40IP X 5/16" HEX BIT	20D240616	5/32" HEX BIT, FOR 1/4" BH	A6178	XNZ SCREW BIT, FOR 5/16" BH	H4533
30IP X 5/16" HEX BIT	20D240617	3/16" HEX BIT, FOR 5/16" BH	A6179	7MM HEX BIT, FOR 1/4" BH	H4909
45IP FOR 5/16" B.H.	20D240618	6MM SQ BIT, FOR 5/16" BH	A6206	7/8 HEX SOCKET	J4850
HEX BIT 5/16, 8MM W/ SPCL FLAT	20D240619	6MM X 5MM BIT, FOR 5/16" BH	A6207	10MM HEX BIT, FOR 5/16" BH	L4259
5MM X 5MM EXT BIT, 5/16" BH	20D240902	T30 HEX BIT, FOR 5/16" BH	A6341	5/16" HEX BIT, FOR 1/4" BH	N4451
5MM X 12.5MM X 5MM EXT BIT 5/16" BH	20D240903	T40 HEX BIT, FOR 5/16" BH	A6373	8MM HEX BIT, FOR 1/4" BH	N4991

H26 Output Options

► **STEP 1:** Choose type of hold & drive:

Option A: Bit Holder See page 106 for config. guide

Option B: Tang Holder See page 107 for config. guide

► **STEP 2:** Choose Hold & Drive travel length — reference EB tool sections for available model number: EB non-fixtured tools, page 11, EB fixtured tools, page 31.

► **STEP 3:** Choose standard socket size of one of the below types:

F4285 SOCKET OPTIONS

Description	Part No.
21MM X 8" EXT, HEX SKT ASM-H26	20D135900
21MM HEX SKT ASM MAG	20D135901
SOCKET 24MM X 8" EXT SURFACE DR	20D213700
21MM X 8.5MM EXT SURF DR - A3H	20D226300
SPECIAL 21MM X 80MM EXT SOCKET	20D232600
23MM HEX SOCKET, A40LA3H	20D232601
27MM X 77MM EXT, H26 SKT	20D232606
HEX SOCKET 1 1/8" SINGLE HEX	20D232609
HEX SOCKET, 21MM X 67.6MM EXT.	20D232610
HEX SOCKET 21MM X 28MM EXT	20D232611
HEX SOCKET 34MM, H26	20D232612
21MM X 12MM EXT SH SKT, H26	20D232615
SOCKET, 18MM X 2.203" EXT., SH H26	20D232616
HEX SOCKET - 18MM X 3.203 EXT.	20D232617
HEX SOCKET-16MM X 5MM EXT SPCL DRIVE DEPTH	20D232618
18MM X 12MM EXT SPCL HEX SKT SPCL 22MM DRIVE DEPTH	20D232619
21MM X 167.3MM EXT SD SKT, H26	20D232621
21MM X 18MM EXT, SH SOCKET, H26	20D232622
18MM X 7.107 OAL, FL, SOCKET, H26	20D232623
10MM SURFACE DR SOCKET	A6137
18MM HEX SURF DR X 1-1/2" EXT S	A6215
22MM HEX - A3H SPECIAL O.D.	A6216
22M SURFACE DRIVE - 1/4 EXT A3H	A6228
14MM DBL HEX SOCKET	A6231
15/16" X 60MM HEX SKT, 40A3H	A6270
21MM SURF DR. X 2" SKT 40A3H	A6467
19MM HEX SURF. DR. X 46MM EXT.	A6474
17MM HEX SOCKET	F4285
19MM HEX SOCKET	F4294
14MM SOCKET	F4359
21MM SOCKET	F4401
22MM HEX SOCKET	F4487
24MM (15/16") HEX SOCKET	F4512
19MM X 16MM EXT SOCKET	F4541
9/16" HEX SOCKET	F4571
18MM HEX SOCKET	F4635
19MM X 10MM HEX SOCKET	F4653
15MM HEX SOCKET	F4717
1-1/16HEX (27MM) SOCKET	F4867
19MM X 7MM SURFACE DR. SOCKET	F4869
21MM SURF DR SOC 15MM DEEP 28MM	H4039
18MM SURF DR SOC 12MM DEEP 28MM	H4040

Description	Part No.
18MM SURF DR SOCKET	H4177
21MM SURF DR SOCKET 182MM EXT	H4366
17MM HEX SURF DR SOCKET 37MM EX	H4409
21MM SURF DR SOC 155MM EXT	H4447
21MM SURF DR SOCKET 10MM EXT	H4486
18MM SURF DR SOCKET 10MM EXT	H4487
17MM SURF DR SOCKET 1.5" EXT	H4576
17MM SURF DR SOCKET 1-5/8" EXT	H4594
18MM SURF DR OVER SIZE	H4612
18MM HEX SOCKET 32MM EXT	H4628
21MM HEX SOCKET 52MM EXT	H4629
17MM HEX SOCKET 36MM EXT	H4781
SOCKET 24MM X 45MM EXT.	H4820
18MM HEX SOCKET 8" EXT	H4886
17MM X 1-1/8" EXT SOCKET	H4959
21MM FAST LEAD SOCKET	J4044
16MM (5/8") HEX SOCKET	J4090
15MM X 1/2 EXT SOCKET LA3H	J4213
17MM HEX SOCKET (SPEC. O.D.)	J4304
19MM X 80MM EXT SOCKET	J4316
19MM X 157MM EXT SOCKET	J4318
19MM X 18MM EXT SURFACE DR	J4381
17MM HEX SOCKET SURFACE DR	J4398
14MM FAST LEAD SOCKET	J4457
17MM X 19MM EXT SOCKET	J4467
22MM FAST LEAD SOCKET LA3H	J4607
17MM FAST LEAD SOCKET LA3H	J4608
15MM SURFACE DR. SOCKET	J4662
9/16 X 1/2 EXT REACTION SOCKET	J4708
15MM X 1" EXT HEX SOCKET (LA3H)	J4829
7/8 HEX SOCKET	J4850
22MM X 80MM EXT SOCKET LA3H	J4989
18MM X 80MM EXT SURFACE DR SOCK	L4067
21MM X 80MM EXT SURFACE DR SOCK	L4068
18MM X 157MM EXT SURF DR SOCKET	L4073
11/16 HEX SOCKET	L4116
18MM 1/4" EXT (SPECIAL OD)	L4118
19MM HEX SOCKET LA3H	L4119
22MM X .52MM EXT HEX SOCKET (LA	L4372
18MM X 80MM SURF DR SKT SPEC O.	L4426
19MM SURFACE DR SOCKET LA3H	L4474
11/16 SOCKET 36MM EXT	L4525

Description	Part No.
16MM X 10MM EXT SOCKET	L4535
18MM SOCKET 1 1/2" EXT	L4556
22MM SURF DR SOCKET 10MM EXT	L4557
30MM HEX SOCKET LA4H	L4622
18MM X 19MM EXT HEX SOCKET LA3H	L4646
24 MM SOCKET 10 MM EXT	L4663
HEX SOCKET 21MM X 300MM	L4733
19 MM FAST LEAD SOCKET	L4868
19 MM SOCKET X 3/8" EXT SPECIAL	L4886
12MM HEX SOCKET (LA3H)	L4897
21MM SURF DR SOCKET 75 MM EXT	N4034
21MM SURF DR SOCKET 150 EXT	N4035
21MM SURF DR SOCKET	N4036
18MM X 37MM EXT SURF DR SOCKET	N4134
21MM X 37MM EXT SURF DR SOCKET	N4135
21MM X 32MM EXT SURF DR SOCKET	N4136
21MM X 107MM EXT SURF DR SOCKET	N4137
21MM X 80MM EXT SURF DR SOCKET	N4149
21MM X 157MM EXT SURF DR SOCKET	N4150
20MM HEX SOCKET	N4177
21MM SURF DR SOCKET 67MM EXT	N4186
21MM HEX SOCKET X 1.531 EXT	N4188
21MM HEX SOCKET 8MM EXT	N4337
21MM HEX SOCKET 57MM EXTENDED	N4382
17MM X 87MM EXT SOCKET	N4398
15MM SURF DR SOCKET 37MM EXT	N4412
24MM SURF DR SOCKET	N4439
22MM SURF DR SOCKET	N4440
18MM HEX SOCKET 1/4" EXT	N4457
21MM X 8.5MM EXT. HEX SOCKET	N4466
18MM X 26.5MM EXT. HEX SOCKET	N4468
15MM X 80MM EXT. SURFACE DR. SO	N4582
18MM HEX SOCKET 187MM EXT	N4696
18MM HEX SOCKET 107MM EXT	N4698
18MM X 3-1/8" EXT HEX SOCKET	N4711
18MM HEX SURF DR SOCKET 80MM EX	N4715
15MM DBLE. HEX SOCKET	N4782
15MM HEX SOCKET (USE W/N4826	N4825
18MM HEX SOC 1-1/2" EXT FAST LE	N4925
18MM HEX SOCKET FAST LEAD	N4926
17MM HEX SOCKET 10MM EXT	N4975
TANG DRIVE SOCKET	S7749

H26 Output Options continued

- ▶ **STEP 4A:** Choose standard bit holder size:

~H4947 H26 BIT HOLDER OPTIONS

Description	Part No.
HEX BIT HOLDER 5/16" HEX	20D241300
BIT HOLDER 80MM EXT (FOR	20D241301
BIT HOLDER 1/4" HEX X STD EXT	A6273
5/16" HEX BIT HOLDER 31MM EXT	H4897
HEX BIT HOLDER 5/16" X 1/4"	H4947
HEX BIT HOLDER 5/16 HEX,	N4631
5/16" X 77MM EXT, BIT HOLDER	N4670

- ▶ **STEP 5A:** Determine socket and/or bit holder extension length required. Calculate the bit protrusion using the following equation: Bit Protrusion (mm) = 19 mm + Bit Holder Extension (mm) – Socket Extension (mm)

- ▶ **STEP 6A:** Choose bit:
~F4296 BIT SELECTION

Description	Part No.
T45 HEX BIT, FOR 5/16" BH	20D240600
T30 HEX BIT, FOR 1/4" BH	20D240601
HEX BIT 5/16 - 8MM X 25mm LG	20D240603
9MM HEX BIT, FOR 1/4" BH	20D240605
5/16" HEX BIT, FOR 7/16" BH	20D240606
T-30 BIT, SPCL LENGTH, 5/16 HLDR EXT 20MM OUT OF HOLDER	20D240609
T-45 BIT, SPCL LENGTH, 5/16 HLDR EXT 20MM OUT OF HOLDER	20D240610
6MM HEX BIT, FOR 1/4" BH	20D240611
T55 BIT 5/16" HEX	20D240613
HEX BIT T40, 1/4 HOLD x1LG	20D240615
40IP X 5/16" HEX BIT	20D240616
30IP X 5/16" HEX BIT	20D240617
45IP FOR 5/16" B.H.	20D240618
HEX BIT 5/16, 8MM W/ SPCL FLAT	20D240619
5MM X 5MM EXT BIT, 5/16 BH	20D240902
5MM X 12.5MM X 5MM EXT BIT 5/16 BH	20D240903

- ▶ **STEP 4B:** Choose tang holder size:
~H4948 TANG HOLDER OPTIONS

Description	Part No.
10MM X 8" EXT, HEX TANG ASM	20D132303
10MM X 7.5" EXT, SURF DR TANG	20D132304
TANG HOLDER 12MM HEX X 8" EXT	20D213800
TANG HOLDER 11MM HEX X STD'D EX	20D215300
TANG HOLDER, 11MM SURFACE DR. -	20D216300
8MM HEX X 1.500 EXT TANG HOLDER	20D216600
9MM FEMALE HEX TANG HOLDER	20D222701
9MM X 2.5" EXT FEMALE HEX TANG HOLDER	20D222704
7MM X 1" EXT TANG HOLDER	20D223900
TANG HOLDER, .343 HEX	20D223901
7.7mm x 9.8mm RECT TANG HLDR	20D223902
8mm X 107mm EXT HEX TANG HOLDER	20D223903
8MM X 6.920" EXT., SH, TANG HLDR	20D223904
E8 TORX TANG HOLDER, A2H/A3H/A4	20D226200
TANG HOLDER, E12 TORX	20D226201
E8 TORX TANG HOLDER SPCL Ø	20D226203
TANG HOLDER, E12 TORX	20D226901
TANG HOLDER 10MM SURF DR H26 HEAD	20D245100
10MM X 1-1/2" EXT, SURF DR TANG	20D245102
10MM X 32MM EXT, SURF DR TANG	20D245103
6MM HEX 6MM DEEP, TANG H26	20D245104
10MM X 67.6MM EXT, SURF DR, TANG HOLDER H22	20D245108
10MM X 67.6MM EXT, HEX, TANG HOLDER H22	20D245109
8.9MM X 11.2MM RECT TANG HOLDE	20D245110
10mm HEX, 64mm O'ALL LENGTH	20D245111
10MM X 55MM OAL TANG H22/H26	20D245112

Description	Part No.
5/16" HEX, TANG HOLDER A22	20D245117
8MM X 51MM EXT HEX TANG HOLDER FOR A22	20D245118
8MM X 2.203" EXT., HEX, TANG H26	20D245119
8MM(5/16) X 3.2" EXT TANG HLDR H26	20D245120
9.1MM x 11.15MM, 168MM EXT TANG H26 TANG HOLDER	20D245122
IP40 DRIVE TANG HOLDER	20D245123
10 X 12MM TANG HOLDER	A6004
10MM HEX FAST LEAD TANG HOLDER	A6030
7.1 X 8.25 MM TANG HOLDER	A6032
TWO STEP TANG HOLDER	A6043
8MM TANG HOLDER 32MM EXT	A6053
6MM X 8MM TANG HOLDER	A6089
5MM HEX TANG HOLDER	A6123
8MM HEX TANG HOLDER	A6132
8.7 X 11MM X 157MM EXT. TANG HO	A6203
6.4MM X 8.4MM TANG HOLDER 40A3	A6288
8.0mm X 80mm EXT. A3H TANG HLD	A6296
10MM HEX X 2" EXT TANG HOLDER "	A6468
8MM MALE HEX HOLDER	H4944
6MM MALE HEX HOLDER/BIT	H4945
12MM HEX TANG HOLDER	H4946
10MM HEX TANG HOLDER	H4948
8MM HEX TANG HOLDER	H4949
10MM HEX TANG HOLD 32MM EXT	H4960
8MM HEX TANG HOLDER 8" EXT	H4982
10MM HEX TANG HOLDER 3.125" EXT	H4983

- ▶ **STEP 5B:** Determine socket and/or tang holder extension length required. Calculate the tang recession using the following equation: Tang Recessed (mm) = Socket Extension (mm) – Tang Holder Extension (mm)

Description	Part No.
6MM X 5MM EXT BIT 5/16 BH	20D240904
SLOTTED BIT, FOR 5/16" BH	20D246700
21MM X 20MM DP, HEX SKT 40A2H	20DS200018
5MM HEX BIT, SHORT, 5/16" BH	20DS200700
6MM HEX BIT, SHORT, 5/16 BH	20DS200701
T40 BIT, SHORT, 5/16 BH	20DS200702
3/8" HEX BIT, FOR 5/16" BH	A5666
1/4" HEX BIT, FOR 5/16" BH	A5668
14MM HEX BIT, FOR 7/16" BH	A5724
T27 TORX BIT, FOR 1/4" BH	A6134
5/32" HEX BIT, FOR 1/4" BH	A6178
3/16" HEX BIT, FOR 5/16" BH	A6179
6MM SQ BIT, FOR 5/16" BH	A6206
6MM X 5MM BIT, FOR 5/16" BH	A6207
T30 HEX BIT, FOR 5/16" BH	A6341
T40 HEX BIT, FOR 5/16" BH	A6373

Description	Part No.
T50 HEX BIT, FOR 5/16" BH	A6403
1/4 HEX BIT, FOR 1/4" BH	A6453
7MM HEX BIT, FOR 5/16" BH	F4296
5MM HEX BIT, FOR 1/4" BH	F4361
5MM HEX BIT, FOR 5/16" BH	F4380
6MM HEX BIT, FOR 5/16" BH	F4399
8MM HEX BIT, FOR 5/16" BH	F4513
SOCKET 14MM X 15MM EXT.	H4223
T15 TORX BIT, FOR 1/4" BH	H4280
SLOTTED BIT, FOR 1/4" BH	H4436
XNZ SCREW BIT, FOR 5/16" BH	H4533
7MM HEX BIT, FOR 1/4" BH	H4909
7/8 HEX SOCKET	J4850
10MM HEX BIT, FOR 5/16" BH	L4259
5/16" HEX BIT, FOR 1/4" BH	N4451
8MM HEX BIT, FOR 1/4" BH	N4991

H32 Output Options

▶ **STEP 1:** Choose type of hold & drive:

Option A: Bit Holder See page 106 for config. guide

Option B: Tang Holder See page 107 for config. guide

▶ **STEP 2:** Choose Hold & Drive travel length — reference EB tool sections for available model number: EB non-fixtured tools, page 11, EB fixtured tools, page 31.

▶ **STEP 3:** Choose standard socket size of one of the below types:

~A5302 1" TRAVEL SOCKET OPTIONS

Description	Part No.
H32 SOCKET - 24MM	20D212101
H32 SOCKET - 27MM	20D212102
23MM HEX SOCKET, H32/A5H 1" TRAVEL	20D212103
22MM SURF DR SKT, H32V1	20D212104
21MM HEX SOCKET 1" TRAVEL	A5302
13/16" (30MM) HEX SOCKET 1" TR	A5306
1-1/8" HEX SOCKET 1" TRAVEL	A5667
41MM HEX	A5722
36MM HEX SOCKET - 50A2H	A5726

~A5303 2" TRAVEL SOCKET OPTIONS

Description	Part No.
36MM HEX SOCKET, A5H HEAD	20D226700
24MM SURFACE DRIVE SOCKET, H32V	20D230100
18MM HEX SOCKET, H32V2	20D230101
34MM HEX SOCKET, A5H, 2" TRAVEL	20D235000
H32 HEX SKT 21MM X 16MM EXT	20D249400
24MM X 16MM EXT HEX SKT, H32V2	20D249401
21MM X 8" EXT SURF DR SKT H32V2	20D249402
21MM X 5.05" EXT., SD, SOCKET, A5H, 2" TRAVEL H&D	20D249403
24MM X 5.05" EXT, SD, SOCKET, A5H, 2" TRAVEL H&D SOCKET	20D249404
30MM SH SKT 2" TRAVEL HND MIN CHAMFER ON SOCKET	20D5201800
21MM X 4 11/16" EXT HEX SKT H32, 8" OVERALL LENGTH	20D5202208
21MM HEX SOCKET 2" TRAVEL	A5303
13/16" (30MM) HEX SOCKET 2" TR	A5316
31MM HEX SOCKET 2" TRAVEL	A5339
22MM HEX SOCKET (2" TRAVEL)	A5383
24MM HEX SOCKET (2" TRAVEL)	A5393
46MM HEX SOCKET 2 IN. TRAVEL	A5718

▶ **STEP 4A:** Choose standard bit holder size:

~20D900602 BIT HOLDER OPTIONS

Description	Part No.
5/16" Hex	A5307
7/16" Hex	A5723
8 MM Special Outside Diameter	20D250100

▶ **STEP 4B:** Choose tang holder size:

~20D900601 TANG OPTIONS

Hex

Size	Extension	Part #	Feature
5/16" (8mm)		A5559	
8mm		20D212204	Special O.D.
10mm		A5301	
10mm	1/4"	A5452	
11mm		A5394	
12mm		20D212201	

Surface Drive

Size	Part #
10mm	A5581
11mm	A5549
12mm	20D212203
13mm	20D212202
15mm	20D212206

Fast Lead

Size	Extension	Part #
10mm		A5399
11mm		A5400
11mm	1/4"	A5453

Rectangle

Size	Extension	Part #
10.32 X 13.1mm		A5585
9 x 12.55mm	80mm	A5384

Torx

Size	Part #
T-18	A5340

H32 Output Options continued

▶ **STEP 5A:** Determine socket and/or bit holder extension length required. Calculate the bit protrusion using the following equation:

$$\text{Bit Protrusion (mm)} = 17 \text{ mm} + \text{Bit Holder Extension (mm)} - \text{Socket Extension (mm)}$$

▶ **STEP 5B:** Determine socket and/or tang holder extension length required. Calculate the tang recession using the following equation:
$$\text{Tang Recessed (mm)} = \text{Socket Extension (mm)} - \text{Tang Holder Extension (mm)}$$

▶ **STEP 6A:** Choose bit:
~F4296 BIT SELECTION

Description	Part No.
T45 HEX BIT, FOR 5/16" BH	20D240600
T30 HEX BIT, FOR 1/4" BH	20D240601
HEX BIT 5/16 - 8MM X 25mm LG	20D240603
9MM HEX BIT, FOR 1/4" BH	20D240605
5/16" HEX BIT, FOR 7/16" BH	20D240606
T-30 BIT, SPCL LENGTH, 5/16 HLDR EXT 20MM OUT OF HOLDER	20D240609
T-45 BIT, SPCL LENGTH, 5/16 HLDR EXT 20MM OUT OF HOLDER	20D240610
6MM HEX BIT, FOR 1/4" BH	20D240611
T55 BIT 5/16" HEX	20D240613
HEX BIT T40, 1/4 HOLD x1LG	20D240615
40IP X 5/16" HEX BIT	20D240616
30IP X 5/16" HEX BIT	20D240617
45IP FOR 5/16" B.H.	20D240618
HEX BIT 5/16, 8MM W/ SPCL FLAT	20D240619
5MM X 5MM EXT BIT, 5/16 BH	20D240902
5MM X 12.5MM X 5MM EXT BIT 5/16 BH	20D240903

Description	Part No.
6MM X 5MM EXT BIT 5/16 BH	20D240904
SLOTTED BIT, FOR 5/16" BH	20D246700
21MM X 20MM DP, HEX SKT 40A2H	20DS200018
5MM HEX BIT, SHORT, 5/16" BH	20DS200700
6MM HEX BIT, SHORT, 5/16 BH	20DS200701
T40 BIT, SHORT, 5/16 BH	20DS200702
3/8" HEX BIT, FOR 5/16" BH	A5666
1/4" HEX BIT, FOR 5/16" BH	A5668
14MM HEX BIT, FOR 7/16" BH	A5724
T27 TORX BIT, FOR 1/4" BH	A6134
5/32" HEX BIT, FOR 1/4" BH	A6178
3/16" HEX BIT, FOR 5/16" BH	A6179
6MM SQ BIT, FOR 5/16" BH	A6206
6MM X 5MM BIT, FOR 5/16" BH	A6207
T30 HEX BIT, FOR 5/16" BH	A6341
T40 HEX BIT, FOR 5/16" BH	A6373

Description	Part No.
T50 HEX BIT, FOR 5/16" BH	A6403
1/4 HEX BIT, FOR 1/4" BH	A6453
7MM HEX BIT, FOR 5/16" BH	F4296
5MM HEX BIT, FOR 1/4" BH	F4361
5MM HEX BIT, FOR 5/16" BH	F4380
6MM HEX BIT, FOR 5/16" BH	F4399
8MM HEX BIT, FOR 5/16" BH	F4513
SOCKET 14MM X 15MM EXT.	H4223
T15 TORX BIT, FOR 1/4" BH	H4280
SLOTTED BIT, FOR 1/4" BH	H4436
XNZ SCREW BIT, FOR 5/16" BH	H4533
7MM HEX BIT, FOR 1/4" BH	H4909
7/8 HEX SOCKET	J4850
10MM HEX BIT, FOR 5/16" BH	L4259
5/16" HEX BIT, FOR 1/4" BH	N4451
8MM HEX BIT, FOR 1/4" BH	N4991

Hold & Drive Standard Sockets



A new part number system for H22 standard hold and drive sockets enables customers to describe and price standard sockets for each application. The part number includes information on head number of the tool, socket type, socket size and extension length. For special sockets or dimensions not included on this page, check the following pages or contact your local STANLEY sales representative.

CHOOSE YOUR SOCKET

STEP 1: Select the Base Code from the Head Number table

STEP 2: Add Type, Size & Extension separated by forward slashes

Note: Specify socket size no smaller than Min. Hex Size.

Hold and Drive Head Number DTU	Min. Hex Size		Base Code	Type	Size		Extension				
	(mm)	(in)			Size (mm)	Size Code	Length (mm)	Length (in)	Extension Code		
H22	17	11/16	20D288400	SH Single Hex	17	M17	11/16	11	Standard	Standard	0
					18	M18	3/4	12	3	1/8	3
					19	M19	13/16	13	6	1/4	6
					20	M20	7/8	14	9	3/8	9
					21	M21	15/16	15	12	1/2	12
					22	M22			15	5/8	15
				DH Double Hex	23	M23			18	3/4	18
					24	M24			21	7/8	21
					SD Surface Drive					24	1
									27	1 1/16	27
									30	1 1/8	30
									33	1 1/4	33
									36	1 3/8	36
									39	1 1/2	39
									42	1 5/8	42
									45	1 3/4	45
									48	1 7/8	48
									51	2	51
									54	2 1/8	54
									57	2 1/4	57
									60	2 3/8	60
									63	2 1/2	63
									66	2 5/8	66
									69	2 3/4	69
								72	2 7/8	72	
								75	3	75	
								78	3 1/8	78	
								81	3 1/4	81	
								84	3 3/8	84	
								87	3 1/2	87	
								90	3 5/8	90	

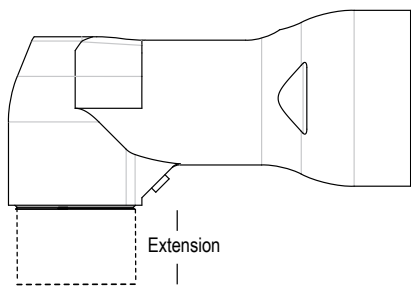

EXAMPLE ORDER

Example: An H22 hold and drive head requires a 17 mm surface drive socket with a 1 in extension. Select the BASE (20D288400), TYPE (SD), SIZE (17) and EXTENSION (24).

Base	Type	Size	Ext.
20D288400	/SD	/17	/24

Note: The standard socket, 0 extension, has an OAL of 1.625". The extended lengths are added to the OAL.

Hold & Drive Bit Holders

A new part number system for H22 standard bit holder enables customers to describe and price standard sockets for each application. The part number includes information on the base bit holder number, drive size and extension length. For special bit holders or dimensions not included on this page, check the following pages or contact your local STANLEY sales representative.

CHOOSE YOUR BIT HOLDER

STEP 1: Select the Base Code based on the bit holder length table

STEP 2: Add Type, Size & Extension separated by forward slashes

Base		Type	Size		Extension		
Bit Holder Length	Base Code	Type	Size [in]	Size Code	Length		Extension Code
Standard Length	20D288500	SH Single Hex 	1/4	4	[mm]	[in]	0
Extended Length < 79 mm (3 1/16")	20D288501		5/16	5	Standard	Standard	3
Extended Length > 79 mm (3 1/16")	20D288502				3	1/8	3
					6	1/4	6
					9	3/8	9
					12	1/2	12
					15	5/8	15
					18	3/4	18
					21	7/8	21
					24	1	24
					27	1 1/16	27
					30	1 1/8	30
					33	1 1/4	33
					36	1 3/8	36
					39	1 1/2	39
					42	1 5/8	42
					45	1 3/4	45
					48	1 7/8	48
					51	2	51
					54	2 1/8	54
					57	2 1/4	57
					60	2 3/8	60
					63	2 1/2	63
					66	2 5/8	66
					69	2 3/4	69
					72	2 7/8	72
					75	3	75
					78	3 1/8	78
					81	3 1/4	81
					84	3 3/8	84
					87	3 1/2	87
					90	3 5/8	90

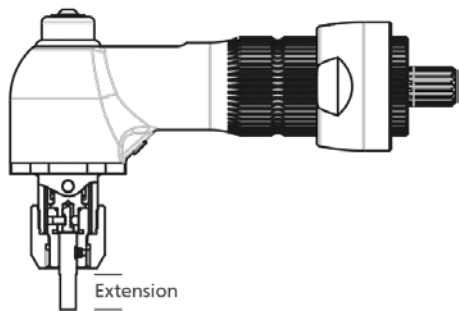

EXAMPLE ORDER

Example: An H22 hold and drive head requires a 1/4" bit holder with a 1 in extension. Select the BASE (20D288500), TYPE (SH), SIZE (4) and EXTENSION (24).

Base	Type	Size	Ext.
20D288500	/SH	/4	/24

Reaction Bars and Mounts

Mounting Options

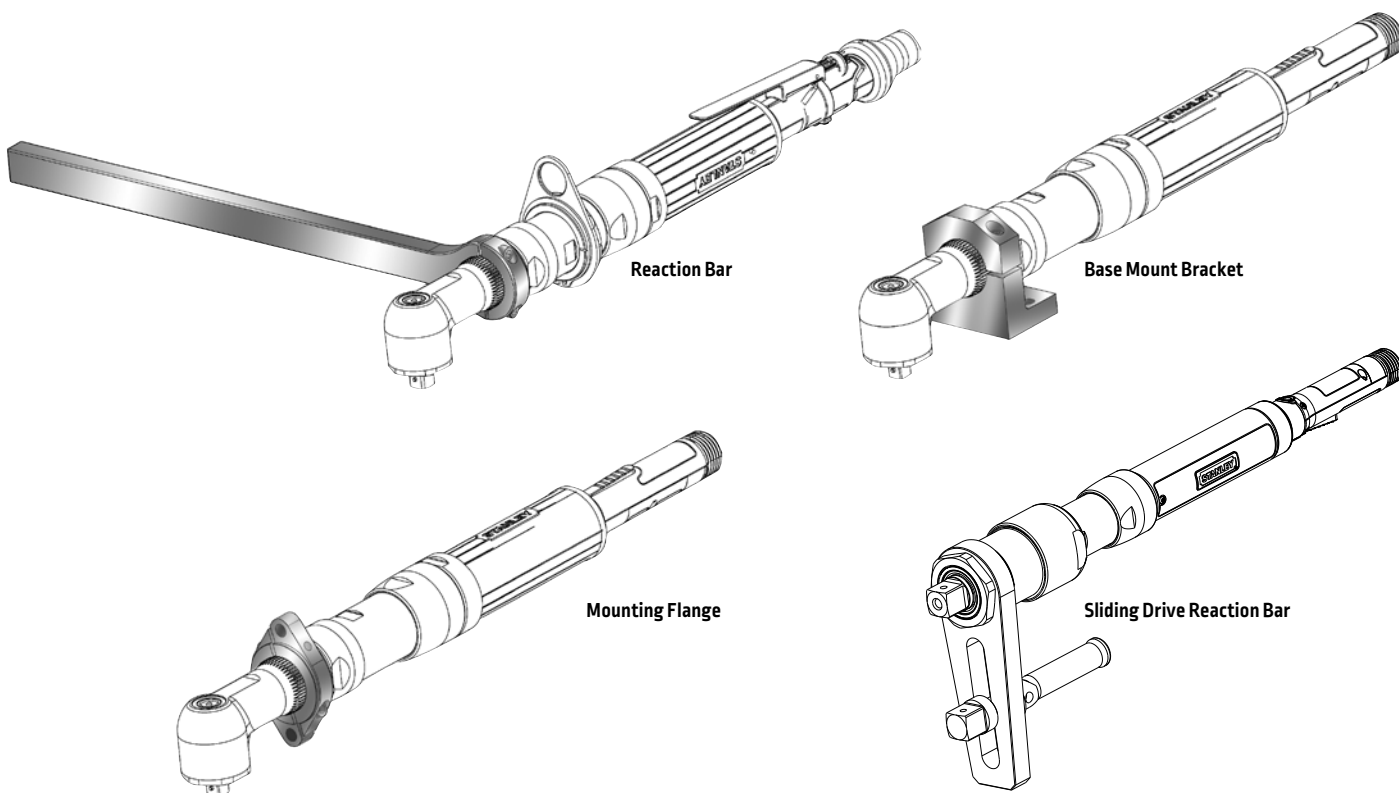

Reaction Devices Listed by Tool Models	E_02LB E_12LB E_12PB EB22PB	EB22LB E_33LB E_33MB E_33PB	E_33LA19 E_34LA19 E_34LA22A/H22A E_34LC/EB34LT E_44LA19 E_44LA22A/H22A E_44LC/EB44LT E_34LB1 E_34MB1 E_44LB1 E_44MB1 E_34PB1 E_44PB1	E_45LA26/H26 E_45LA32/H32 E_55LA26/H26 E_55LA32/H32 E_45LB2 E_45MB2 E_55LB2 E_55MB2	E_55LB3 E_55MB3	E_55LB4 E_55MB4	E_55LB5 E_55MB5
Base Mount Bracket		A8606	20K100500	20K100600	H1140	F4201	
Mounting Flange		20K101000	20K100300	20K100700	M4329	20K101100	20K100900
Reaction Bar - Steel	20K100104	20K100100	20K100000	20K100200	B4487	F4192	
Reaction Bar - Heavy Duty				20K100202			
Reaction Bar 17" - Aluminum	20K100103	F3698					
Reaction Bar 12" - Aluminum	20K101601						
Sliding Drive Reaction Bar						F4857	

Wire Bails and Gear Case Extensions

Tool Bails

Wire Bails allow a tool to be hung on a hook for storage until needed.

Swivel Bails allows for a balancer to hold the weight of the tool while the operator uses the tool in the correct position as the tool is free to rotate inside the bail.

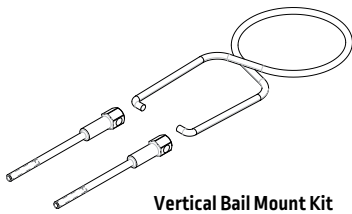

Vertical Bail Mount Kit

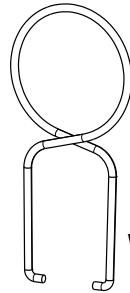

Wire Bail

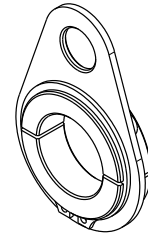

Swivel Bail

Bail Devices Listed by Tool Models	E_02LA E_02LB E_12LA E_12LB	EB22P	E_33P	EB22L E_33L	E_34P E_44P	E_34L E_44L	E_45L E_55L
Swivel Bail	20K101402		20K101400	20K101400	20K200000	20K200000	20K200100
Vertical Wire Bail	A3061	A3061	A3061	A3061	A3061	A3061	
Vertical Bail Mount Kit			20K200007		20K200007		

Gear Case Extensions for Angle Tools

Gear Case Extensions fit between the gearing and an angle output to extend the reach of the tool.

Use these Part Numbers to extend an existing tool. When ordering a new tool simply use E# after the tool model number to have the extension installed on the new tool. Where # is the length in inches for the extension required.

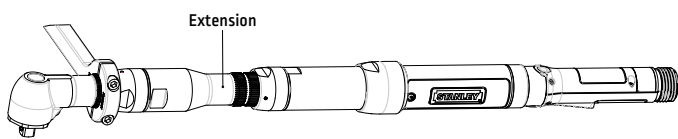

Tool Type	Gearing Size	Output	Extension	Part Number
E	G3	A15/ A18/ A19 Threaded	4"	20K300019
E	G3	A15/ A18/ A19 Threaded	6"	20K300025
E	G3	A15/ A18/ A19 Threaded	10"	20K300020

Tool Type	Gearing Size	Output	Extension	Part Number
E12/EB_2/AA	G2	A10/ A13	2"	20K300026
E12/EB_2/AA	G2	A10/ A13	6"	20K300027

Tool Type	Gearing Size	Output	Extension	Part Number
E/EB/AA	G4	A19 Splined/ A22A	4"	20K300014
E/EB/AA	G4	A19 Splined/ A22A	6"	20K300013
E/EB/AA	G4	A19 Splined/ A22A	8"	20K300015
E/EB/AA	G4	A19 Splined/ A22A	10"	20K300016
E/EB/AA	G4	A19 Splined/ A22A	12"	20K300018

Tool Type	Gearing Size	Output	Extension	Part Number
EB/AA	G3	A15/ A18/ A19 Threaded	4"	20K300028
EB/AA	G3	A15/ A18/ A19 Threaded	6"	20K300029
EB/AA	G3	A15/ A18/ A19 Threaded	8"	20K300030
EB/AA	G3	A15/ A18/ A19 Threaded	10"	20K300031
EB/AA	G3	A15/ A18/ A19 Threaded	12"	20K300032

Tool Type	Gearing Size	Output	Extension	Part Number
E/EB	G5	A26/ A32	6"	20K300006
E/EB	G5	A26/ A32	9"	20K300009
E/EB	G5	A26/ A32	12"	20K300012

Extended Spindle Support

Extended Spindle Support Accessories

Extended Spindle Supports minimize tool vibration from sockets and extensions. Extended Spindle Support Accessories can help to improve:

- **Safety** — Minimize the pinch hazard between the tool and the extension
- **Product Quality** — Reduce the potential for product damage by helping to prevent tool contact with finished surfaces and cross-threading caused by improper fastener installation
- **Tooling Reliability** — Extended Spindle Support Accessories incorporate a heavy duty bearing that minimizes wobble and reduces side loading to reduce premature tool wear and improve tool reliability
- **Attachment Lifecycle** — Extends socket and extension life

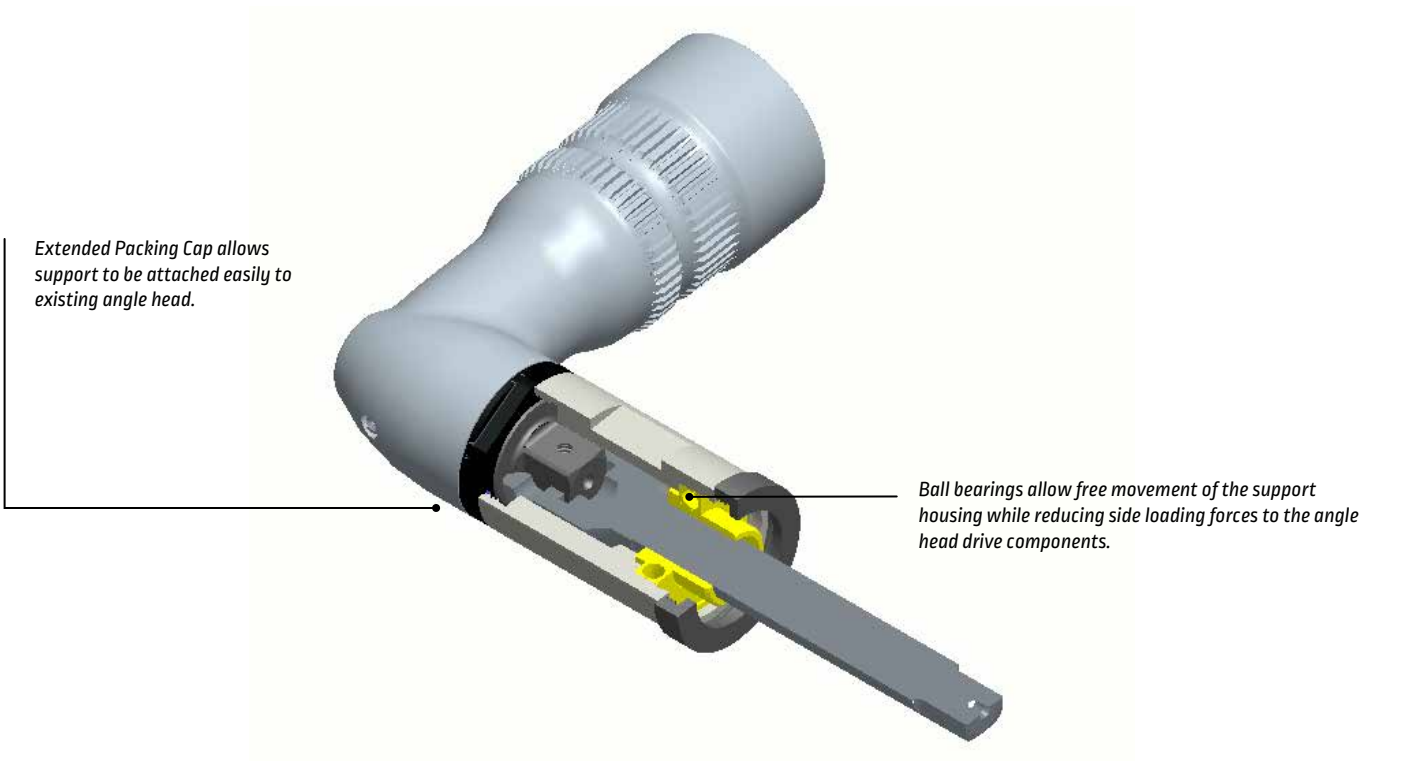

Each Extension Support requires an Extended Packing Cap from the table on the right.

Extension Support Assemblies*

Output	Square Drive (in)	4" Extended Spindle	6" Extended Spindle	8" Extended Spindle	12" Extended Spindle
A14	3/8"	20K102504		20K102505	
A15	3/8"	20K102506	20K102508	20K102507	
A18	3/8"	20K102500	20K102509	20K102501	20K102511
A19	1/2"	20K102502		20K102503	
A22	1/2"	20K102514		20K102515	

*Includes support and extension

Extended Packing Caps

Output	Part Number
A14	20D140102
A15	20D140104
A18	20D140100
A19	20D140101
A22	20D286504

Protectors and Head Covers

Angle Head Covers



PVC Cover

Angle Output	PVC Cover	Vinyl Cover
A13	X2300	20D250705
A14/ A15	X2322 / 20K202103	20D250701
A18	X2323	20D250702
A19	20K202100	20D250707
A22	X2305	20D250708
A26	X2306	20D250709
A32	n/a	20D250710



Angle Head Vinyl Cover

Crowfoot Vinyl Head Covers



Crowfoot Vinyl Cover

Crowfoot Output	Angle Head Cover	Foot Cover
C7	20D250707	20D250722
C10	20D250708	20D250712
C13	20D250703	20D250714
C16	20D250707	20D250715
C29	20D250702	20D250718
C31	20D250708	20D250719
C69	20D250702	20D250721
C246	20D250702	20D250717
C21	20D250709	20D250722
C313	N/A	20D250731
C317 / C379	N/A	20D250732
C216	20D250702	20D250744

Tubenut Vinyl Head Covers

Tubenut Output	Angle Head Cover	Foot Cover
T20	20D250708	20D250725
T23	20D250707	20D250727
T74	20D250702	20D250729
T99	20D250707	20D250730
T147	20D250702	20D250724
T211 / T252	20D250702	20D250726
T264	20D250702	20D250728



Tubenut Vinyl Cover

Tool Lever and Headlights

Lever Handle Options

Rubber Grip for Handle

Handle Type	Tool	Part Number
Pistol	E_02P	20H207107
	E_12P	
	E_2_P	
	E_3_P	
Lever	E_02L	20H207910
	E_12L	20H207207
	E_2_L	
	E_3_L	
	E_4_L	
E_5_L		
Push-to-Start	E_02LP	20H207915
	E_12LP	

Forward Facing Lever

Handle Type	Tool	Part Number
Lever	E2/3_L	20H100005
	EA2/3_L	20H100008
	E4/ 5_L	20H100105
	EB3/5_L, B1/2_L	20H100107
	EB22L	20H100108



Forward Lever

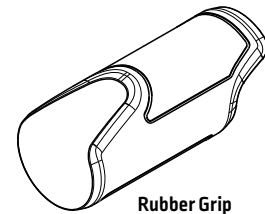

Rubber Grip

Extended Lever

Handle Type	Tool	Part Number
Lever	E_0/12_L	20H101903
	E_2/3/4/5_L	20H100007

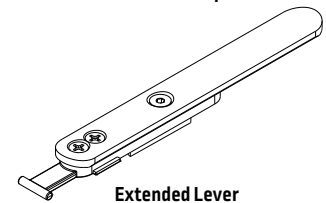

Extended Lever

Headlights

Tool LED Headlight

Tool	Light Type	Part No.
EB33	Stationary	20H106500
EB34		20H106501

Pinch Protectors

Angle Head Output	Part No.
A14	20D286705
A15	20D286704
A18	20D286706
A19 / A22	20D286707

Note: The appropriate extended packing cap is required when installing/using the pinch protectors.



Socket Trays

Socket Trays

STANLEY's 4 and 8 position Socket Trays, available in 24V DC or DeviceNet models, allow a single tool to reliably assemble joints at different target torque levels, batch counts or fastening strategies maximizing quality, productivity, efficiency and floor space. Features include:

- I/O repeater provides access to controller 24V DC I/O not consumed by the Socket Tray (*Optional*)
- Compact design for maximum space saving
- Ready for Alpha using Binary +1 selection
- 8-Position socket tray dimensions: 216d x292w x163h mm (8.5 x 11.5 x 6.4 in)



Socket Tray Model Number	# Socket Positions	Connection	Repeater Port	Cable	Max Socket Diameter
SA-1980	4	24V DC I/O	No	24V DC I/O cable Required, See Below	54 mm 2-1/8"
SA-1981	8		No		
SA-1982	4		Yes		
SA-1983	8		Yes		
SA-1978	4	DeviceNet	No	DeviceNet Cable and Tee Required, See Below.	
SA-1979	8		No		

When using multiple sockets and programs please ensure that the torques programmed are within the working specifications of the tool and controller used.

Cable Number	Connection	Controller	Length
20C109007	24V DC I/O	Advanced/Expert	7 meters
20C109010			10 meters
20C109107		Basic	7 meters
20C109207		PSI-C	7 meters
21C1021.2	DeviceNet	DeviceNet Master	0.2 meters
21C102101			1 meters
21C102105			5 meters
21C102110			10 meters
21C102120			20 meters

Kit Number	Description
21C101401	DeviceNet Cable Tee/ Terminator Kit
21C101403	DeviceNet Cable Kit - 0.2 meter Extension
21C101404	DeviceNet Cable Kit - 1 meter Extension

DeviceNet Micro Tee - 21R202204
 DeviceNet Micro Terminator Male - 21R202202
 DeviceNet Micro Terminator Female - 21R202203

Test Fixtures

Training Joint Simulator

Part Number 20V101000 Has three 1/2" – 13 Bolts with Hard Medium and Soft Joints. Can be mounted to table tops or other significant structures for learning different strategies on different joint characteristics.

20V101000



Calibration Joint Simulator

Model	Joint Type	Max Input Torque		Torque Rate		Bolt Size
		Nm	ftlb	Nm/°	ftlb/°	
T00915/S3	Soft	60	45	14	10.3	3/4 - 16
T00915/S4		88	65	22.6	16.7	
T00915/S5		135	100	34	25	
T00915/S6		200	148	50	37	
T00915/H1	Hard	20	15	125	92.4	5/8 - 11
T00915/H2		40	30	285	210	
T00915/H3		54	40	405	300	3/4 - 16
T00915/H4		75	55	610	450	
T00915/H5		135	100	950	700	
T00915/H6		200	148	1700	1257	

Calibration Joint Simulator



Test Fixtures and Handles

DC Start Handle

Use Part Number M4504 as a second handle for positioning tools that are fixtured and then starting their operation. Use one of the X5380/x cables listed with this handle.

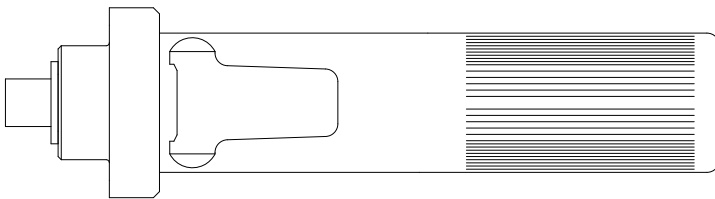
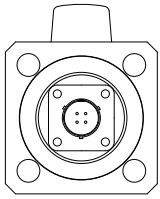

Part No.	Length
X5380/1	1 meter
X5380/3	3 meters
X5380/10	10 meters
X5380/30	30 meters
X5380/60	60 meters

Auxiliary Handle

Use Part Number S3544 as an Auxiliary Handle for positioning tools that are fixtured.

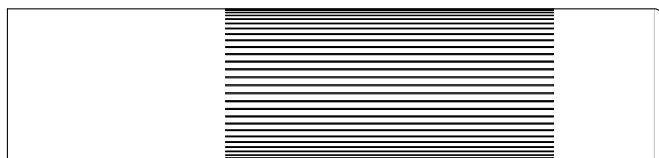
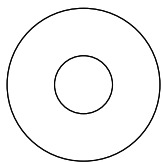

Floor Stands

Floor Stands

Floor Stands provide a place for mounting groups of controllers typically found in fixtured tool applications. However, handheld tools could also be grouped for convenience.

Model	Max Number of Spindles	Description
21F100405	2	For controllers and a Power Module
21F100406		For controllers only
21F100403	6	For controllers and a Power Module
21F100404		For controllers only
21F100401	12	For controllers and a Power Module
21F100402		For controllers only

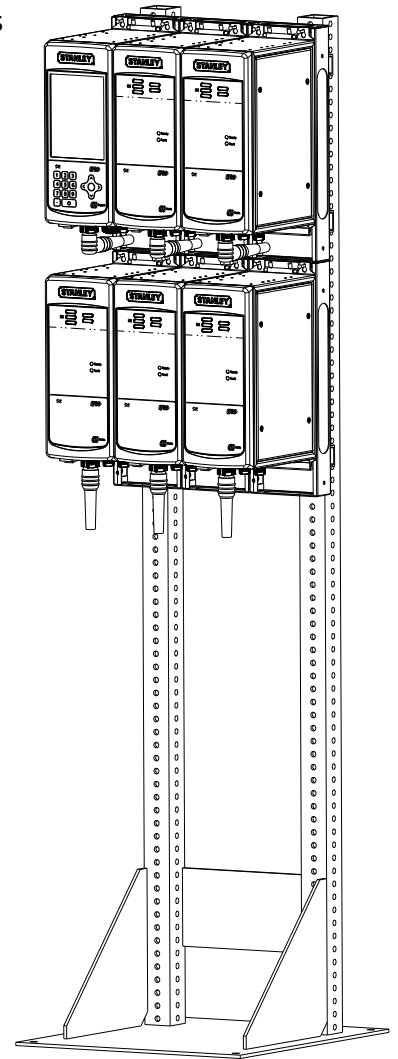

Plinth Brackets & Options

A plinth bracket provides a mounting option for controllers on walls or floor stands. Additional mounting brackets are available for I/O or Ethernet switch mounting options.

Part No.	Description
21E204300	Plinth modular mount bracket
21E204320	Plinth bracket – I/O option
21E204340	4 spindle ethernet switch mounting bracket
21E204341	4 spindle ethernet switch mounting bracket
21E204351	Plinth GFI bracket

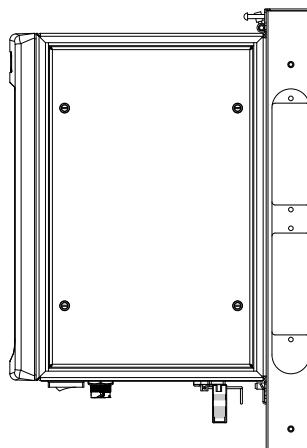

Maintenance Tools

Assembly/Disassembly Maintenance Tools

SPANNER OR CROWFOOT WRENCH

Description	Part No.
3/4" x 3/8" SD	X4174
1" x 3/8" SD	X4175
1-1/16" x 1/2" SD	X4176
1-1/8" x 1/2" SD	X4177
1-1/4" x 1/2" SD	X4179 / X4214
1-3/8" x 1/2" SD	X4181
1-7/8" x 1/2" SD	X4186
2" x 1/2" SD	X4187
2-5/16" x 1/2" SD	X4189 / X4209
2-1/4" x 1/2" SD	X4190 / X4208
1-3/8" x 1/2" SD	X4192
2-3/16" x 1/2" SD	X4191 / X4207

Description	Part No.
1-1/2" x 1/2" SD	X4193
1-5/8" x 1/2" SD	X4194 / X4183
1-3/4" x 1/2" SD	X4195
1-3/16" x 1/2" SD	X4196 / X4188
1-13/16" x 1/2" SD	X4197
1-11/16" x 1/2" SD	X4200
1-7/16" x 1/2" SD	X4204
1-9/16" x 1/2" SD	X4205
1-5/16" x 1/2" SD	X4215
1-7/16" x 1/2" SD	X4216
1-15/16" x 1/2" SD	X4201 / X4219

Description	Part No.
2-1/2" x 1/2" SD	X4210 / 20V200001
2-15/16" x 1/2" SD	20V200002
2-3/4" x 1/2" SD	20V200003
2-7/8" x 1/2" SD	20V200004
3-3/8" x 1/2" SD	20V200005
2-1/8" x 1/2" SD	X4206 / 20V200006
3" x 1/2" SD	20V200007
3-1/4" x 1/2" SD	20V200008

These spanners are used to assemble or disassemble the lock nuts and outputs of QPM tools. See the specific tool's Assembly Sheet for which spanner to use on the tool.

OUTPUT ASSEMBLY/ DISASSEMBLY TOOLS

Description	Part No.
A13 PACKING CAP ASSEMBLY TOOL	T00576
A14 PACKING CAP ASSEMBLY TOOL	20V200400
A18 PACKING CAP ASSEMBLY TOOL	T00698
A19 PACKING CAP ASSEMBLY TOOL	20V100201
A19 BEARING PRESS AID	20V100202
A19 BEARING PRESS AID	20V100209
A22 BEARING PRESS AID	20V100203
A26 BEARING PRESS AID	20V100206
A32 BEARING PRESS AID	20V100207
A14 PINION PULLER	T05108
A19 / A22 PINION PULLER	20V100400
A26 / A32 PINION PULLER	20V100401

These tools are used to Assemble/ Disassemble the outputs of the QPM DC tools. See the specific tool's Assembly Sheet for which spanner to use on the tool.

MOTOR CONNECTOR REPAIR KIT

Description	Part No.
E TOOL CONNECTOR REPAIR KIT	20M202900
EA, EB, EC TOOL CONNECTOR REPAIR KIT	20M202901

MISCELLANEOUS TOOLS

Description	Part No.
A30 / A40 / A18 Drive Spindle Pusher	T01849
SPANNER WRENCH	T05389
T30 BIT (USE W/ 5/16" HOLDER)	X4198
E3 MOTOR CLAMP	20V100001
E3 THREADED ADAPTER SPANNER	20V100002
E4 / E5 MOTOR CLAMP	20V100101
E4 / E5 THREADED ADAPTER SPANNER	20V100102
E12 HD KIT INSTALL SPANNER	20V100210
QPM CONNECTOR REPAIR TOOL KIT	20V100300
MOTOR TESTER, 115V AC	20V100600
MOTOR TESTER, 230V AC	20V101100

These tools are used to repair or test QPM DC tools. Attend Tool Repair Training to learn how to use these tools.

Assembly Tool Definitions



Assembly tool selection considers the power source, control method, tool geometry and torque level. STANLEY Assembly Technologies can tailor these parameters to fit each threaded fastening application.

Power Sources: **Electric vs. Pneumatic**

ELECTRIC:

STANLEY brushless DC electric motors offer the highest level of control, working cleaner, quieter and more efficient than pneumatic tools. STANLEY brushless DC electric motors use rare earth magnets and resolver based commutation for high efficiency and reliability. Microprocessor control adjusts torque, speed, and acceleration independently in either forward or reverse directions. DC electric control offers useful fastening strategies that incorporate patented speed control algorithms that sense the torque rate of the joint and, when necessary, automatically reduce the motor speed to minimize torque overshoot. DC electric

tools require the least amount of maintenance of any type of power tool which reduces the total cost over the life of the tool.

PNEUMATIC:

Pneumatic tools use the compressed air systems available in most assembly plants. They offer excellent power to weight ratios and are usually the most economical choice for many fastening applications. STANLEY's pneumatic motors have a low inertia, locked rotor design that uses low friction materials which provides for a more efficient design with higher speeds. Pneumatic motors are easily maintained to give many years of reliable performance.

Control Methods

The control method should match the joint specifications and the quality assurance required. For the most critical applications, microprocessor based controllers can perform 100% inspection of the dynamic applied torque and collect statistical process control data. Such methods can eliminate the need for secondary inspection processes. When control requirements are less demanding STANLEY also offers more economical ways to control torque to the required specifications.

Electronically Controlled

Shut Off: Available for electric tools, electronic control uses a torque transducer in the tool connected to a microprocessor based controller. The controller monitors the dynamic fastening torque and shuts off the tool when the torque reaches the preset value. This closed loop control method precisely controls dynamic torque.

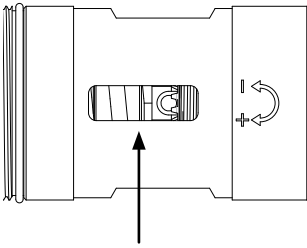

Torque Adjuster

Convenient clutch adjuster is always accessible

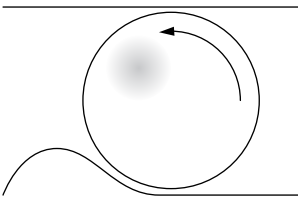

Unique Clutch Rolling Action

Durable rolling element reduces the need for torque adjustment

Electronic Monitoring: Tools without electronic shut off capability may be monitored by monitoring the dynamically applied torque process. A microprocessor based monitor observes the compressed air signature for each fastener for 100% inspection. Similar to electronic shut off tools, electronically monitored tools typically include indicator lights to alert the operator to Pass / Fail status.

Clutch Actuated Shut Off: Clutch actuated shut off tools use a fast acting torque sensing clutch to disengage the motor from the drive spindle at a preset torque level. The system also shuts off the power to the motor. This fast shut off reduces the effect of operator

technique on the applied torque value and the torque reaction impulse felt by the operator. Clutch actuated shut off tools reduce torque variability as compared to standard pneumatic tools. The low torque reaction impulse makes clutch actuated shut off tools ideal for hand held applications. Torque is adjusted at the tool and is not affected by variations in the supply air pressure.

STANLEY's exclusive rolling element clutch eliminates the frictional elements commonly found in competitive tools. This allows extremely close torque control without the need for repeated torque adjustment with clutch wear.

Tool Geometry

STANLEY offers a wide choice of pneumatic and electric tool configurations to allow the process engineer to select a tool that best suits the application. There are two primary tool classes into which tool configurations fit:

Hand Held: Applications which require an operator to maneuver the tool to the fastener and manipulate it throughout the assembly process require hand held tools. Hand held tools are available configured as any of the tools listed in the configuration section that follows. The proper selection of these tools involves

a thorough understanding of the required task and a working knowledge of the resulting torque reaction and the human factors involved in the performance of the task. Every effort has been taken in the design of these tools to make them as user friendly as possible considering the work they must perform. The most critical step is in the selection process as operator safety should always be given the highest priority.

Fixture: Fixture nutrunners typically mount to semi automatic equipment for manipulation during single or

Assembly Tool Definitions

multi-tool assembly operations. Multiple spindle fixtured tools allow the simultaneous assembly of multiple fasteners. Output configurations are Right Angle, Inline, and Offset. Offset spindle heads allow for simultaneous fastening on closer center distance. All these configurations are available with retractable spindle outputs.

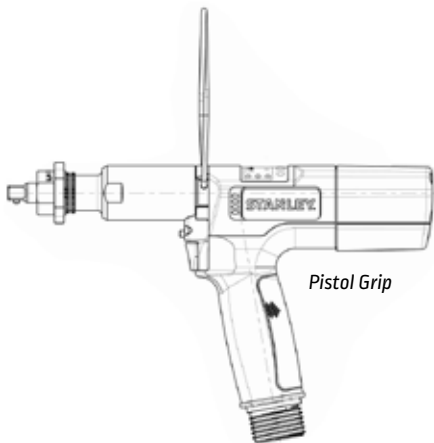

Pistol Grip

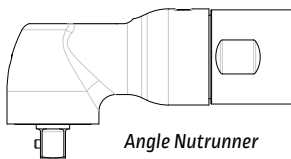

Angle Nutrunner

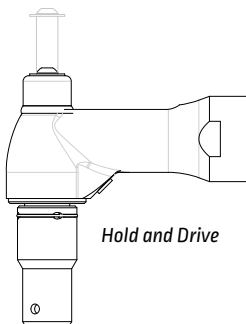

Hold and Drive

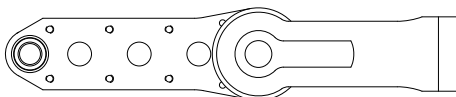

Crowfoot Nutrunner

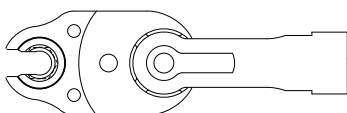

Tubenut Nutrunner

Nutrunners with reaction bars can mount on articulating arms or torque reaction balancers. These devices absorb torque reaction forces and help the operator to position the tool. Many hand held tools use mounting hardware for fixtured applications. Other assembly motors have mounting flanges for fixturing.

Tool Geometry — Configurations

Pistol Grip (1 to 670 Nm Capacity – 1/4" to 1/2" Drive Size): Pistol grip tools are commonly used for hand held, low torque screw driving applications as well as higher torque fixtured or hand held applications where a reaction device can be used to absorb the torque reaction forces. Care should be taken to assure that the operator's wrist is not strained during the use of these tools. Special tools can go up to 1200 Nm.

Angle Nutrunners (1 to 400 Nm Capacity – 1/4" to 3/4" Drive Size): Angle nutrunners are well suited for many assembly applications. The minimal dimensions of our angle heads allow them to reach into restricted places, while their longer effective length reduces the torque reaction forces on the handle. For higher torque applications, these tools can be fitted with torque reaction devices. STANLEY offers a broad line of air and electric angle nutrunners with a variety of control methods.

Hold and Drive (15 to 380 Nm Capacity): Hold and drive tools simultaneously hold the bolt while the nut is tightened. A formed end on the bolt interfaces with a mating tang or bit, to prevent bolt rotation while the associated nut is tightened.

Crowfoot Nutrunners (Standard Tools – 1 to 216 Nm Capacity. Special Tools to 1500 Nm– 4 to 40mm Hex Socket): Crowfoot nutrunners use special tool geometries to access hard to reach applications where more conventional tools won't fit. Gear driven heads provide high levels of torque control. Special head designs can solve most demanding assembly problems.

Tubenut Nutrunners (1 to 100 Nm Capacity – 8 to 32mm Hex Socket): Tubenut nutrunners typically fasten the compression fittings on fluid lines. They can also fasten cable assemblies and tie rod adjustment applications. After tightening the tool returns the socket to the home open position for removal of the tool.

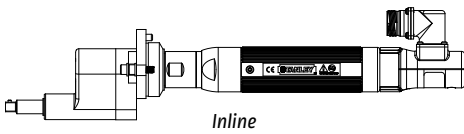

Inline (1 to 2000 Nm Capacity – ¼" to 1" Drive Size): Straight tools are suitable for screw driving applications where the applied torque is relatively low. They are also useful in higher torque applications when the tool is fixtured to absorb the torque reaction or equipped with a torque reaction bar. The reaction bar is placed against a solid support to absorb the torque reaction impulse.

Torque Level

Once the power source, the control method and the tool configuration have been considered, the torque level must also be considered before selecting the exact tool model. STANLEY offers a wide selection of torque ranges for each specific type of tool listed. The rated torque values shown represent the highest torque level that can be expected from that model. Torque can always be adjusted down, but never above the rated value. A general rule of thumb is that most electric tools can be reasonably adjusted to 50% of their rated torque. If the application requires the torque to be adjusted significantly below the rated value, it is often better to choose the next lower rated tool as generally this will provide a faster tool.

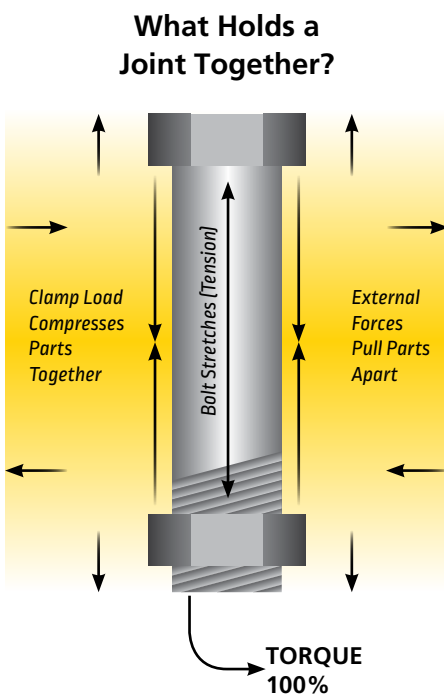

Torque Defined — THE ANATOMY OF A THREADED JOINT

When we assemble a threaded joint, we rotate the fastener by applying Torque (in this example we hold the bolt and rotate the nut). The thread pitch causes this rotation to advance the nut and stretch the bolt.

This produces tension within the bolt just as if it were a large spring. This Tension in the bolt produces the Clamp Load that holds the assembled parts together. And this clamp load must be sufficient enough to resist all the external forces that can be applied to this assembly throughout its service life.

The bolt acts like a very stiff spring. The more Clamp Force the bolt applies, the more service loads the joint can resist without coming apart. Of course, the bolt must be selected to have sufficient strength to resist the expected external loads. The bolt must also be assembled so that it holds the parts together when the external loads attempt to pull it apart.

The process of tightening a fastener is sometimes called “pre-loading” the fastener. This creates tensile load in the bolt, which “pre-loads” the joint to counteract the expected service loads.

Assembly Tool Definitions

The 50-40-10 Rule

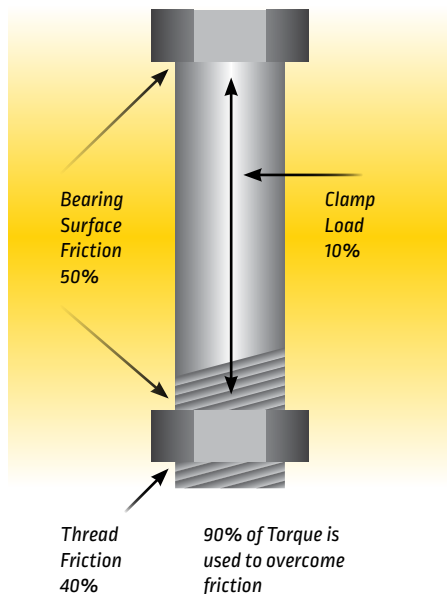

WHERE DOES IT ALL GO?

When we apply a certain amount of torque to a fastener, fifty percent of that torque is used to overcome the friction of the bearing surface (under the nut, or under the bolt head, depending on which is being rotated). Forty percent of the applied torque is used to overcome the friction in the threads. With only ten percent of the applied torque actually used to stretch the fastener.

As we saw earlier, it is the stretch of the fastener that produces the clamping force that actually holds the assembled parts together. This is called the "50-40-10 Rule" and it demonstrates how much influence friction can have on the results. To ensure the best possible joint you should be as diligent as possible in maintaining consistent friction characteristics of the joint.

Tightening Accuracy

The primary driver for delivering even clamp load to an application over many joints of the same design is consistent friction and consistent applied torque. Inconsistent application of torque from one joint type to another can affect the applied clamp load.

There are usually two types of joints; hard and soft. A hard joint is defined as reaching full torque via a tightening angle of roughly 30° after the bolt, or nut, has reached snug level. Snug is usually defined as 10% of the final torque value. In a soft joint, the bolt or nut sometimes has to be tightened more than two complete turns, or over 720° before the full torque is reached.

Assembly tools often give different torque values on hard and soft joints when set to the same torque target. Inertial effects and the ability of the tool to stop movement and applying torque quickly cause this difference. The difference in torque values is generally known as mean shift. Lowering the effect of mean shift increases the possibility of consistent clamp load and is achieved through precision design and patented ATC software available on all electric tooling from STANLEY. **For more information on mean shift and accuracy, see ISO-5393 or contact your local STANLEY sales professional.**

Before ATC

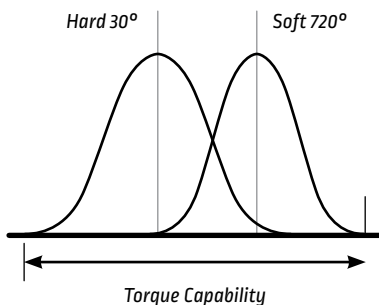

After ATC

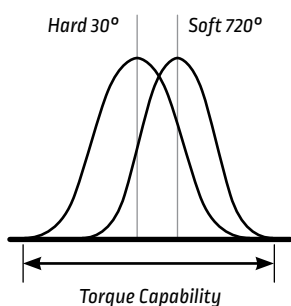

Adaptive Tightening Control (ATC) gives each tool the flexibility to adjust for different joint designs and variable part tolerances. Two fasteners may have the same size and torque specifications, but different joint characteristics (e.g. hard versus soft joints, which require different tightening methodologies). Without ATC, either torque overshoot or long cycle times result. ATC improves torque capability and reduces cycle time by automatically adjusting to joint variations, therefore minimizing the number of tools and set-ups.

Limited Warranty Statement

STANLEY Assembly Technologies products are warranted against defects in material or workmanship by STANLEY Black & Decker, Inc. ("STANLEY") for the useful life of the product. This limited lifetime warranty does not apply to (i) the PSI-intelligent air tool product line; (ii) software; or (iii) electrical components, which are warranted for a period of eighteen months from date of shipment by STANLEY to the initial purchaser.

STANLEY will repair or replace, at its option, any STANLEY Assembly Technologies product which, upon inspection of the product by STANLEY, is determined to be defective within the warranty period. STANLEY may from time to time elect to repair or replace a product at no charge even though STANLEY has determined that the product was not defective. The decision to repair or replace a product at no charge shall not be deemed an admission that the product is defective.

Warranty Repairs performed by STANLEY or a STANLEY Certified Repair Center and replacement products are warranted for a period of 90 days from the date the repaired or replacement product is delivered or the remainder of the original warranty period, whichever is longer.

The foregoing warranties shall not apply to standard wear parts, such as bevel gears, to defects or damage arising after the warranty period expires, or due to:

1. Failure to maintain and use the product in accordance with the instructions provided;
2. Use of non-genuine STANLEY replacement parts;
3. Accidents, tampering, modification, misuse, abuse, or abnormal wear and tear;
4. Repair services not performed by or at the direction of STANLEY; or
5. Continued use after partial failure.

OEM Products

Some STANLEY Assembly Technologies custom engineered systems include components manufactured by others. The limited warranties of each individual manufacturer shall apply to these components and STANLEY makes no representation or warranty of any kind, expressed or implied, with respect to such components.

General Terms

THE ABOVE WARRANTIES ARE EXCLUSIVE AND ARE IN LIEU OF ALL OTHER WARRANTIES, EXPRESS OR IMPLIED, INCLUDING THE IMPLIED WARRANTIES OF MERCHANTABILITY AND FITNESS FOR A PARTICULAR PURPOSE. STANLEY's sole responsibility shall be to repair or replace products under warranty as set forth herein; STANLEY shall not be responsible for incidental or consequential damages or the inability to use its products for any purpose whatsoever. STANLEY's maximum liability shall not in any case exceed the contract price for the products claimed to be defective. Some states and countries do not allow limitations on implied warranties or the exclusion or limitation of incidental or consequential damages so one or more of the above limitations may not apply to you. You may also have other rights which vary by state or country.

Warranty Claims

To obtain warranty service, please take the product to your STANLEY Certified Repair Center OR:

- a) Contact the STANLEY Assembly Technologies customer service department to obtain a "Return Authorization Number" and "Warranty Claim Report Form."
- b) Package the product including proof of purchase and the completed warranty claim form.
- c) Note the Return Authorization Number on the exterior of the package and return freight to:

STANLEY Assembly Technologies
Central Repair Facility
5335 Avion Park Drive
Cleveland, Ohio 44143-2328

Certification and Compliance

ISO CERTIFICATION

STANLEY Assembly Technologies has successfully met the requirements of the ISO 9001 – Quality Systems International Standards for Quality Management and Quality Assurance. The requirements included a review of our quality management system covering the design of our products and our processes for procurement, production, delivery and quality assurance for our Cleveland, Ohio facility.



CE COMPLIANCE

All STANLEY Assembly Technologies' products shipped to the European Union conform to the appropriate CE directives and EC Machine Directives. All products bear the CE marking and are shipped with the operator's instructions and declaration of conformity. We maintain the required technical files and all products are tested in accordance with the EN test code standards.



Index

AA-Series Tools	85	EB-Series Corded Lever Tools	
AA Angle Tools	86	EB-Series Torque Range: Pistol & Lever Style	14-18
AA Inline Tools	87	Angle Lever Tools	19, 20
AA Hold & Drive Tools	88	Inline Pistol Grip Tools	21
AA Crowfoot Tools	89	Inline Push-to-Start Pistol Grip Tools	22
AA Repair Accessories	90	Inline Push-to-Start Lever Tools	23
DC Electric Headlight Aim Tools	91	Inline Lever Tools	23, 24
About STANLEY Fastening	5	Crowfoot Lever Tools	25, 26
Accessories		Tubenut Lever Tools	27
Reaction Bars and Mounts	118	Hold and Drive Lever Tools – 1" Output	28
Wire Bails and Gear Case Extensions	119	Hold and Drive Lever Tools – 2" Output	29
Extended Spindle Support	120	EB-Series Corded Fixtured Tools	31
Protectors and Head Covers	121	EB-Series Torque Range: Fixtured Style	32-36
Tool Lever and Headlights	122	Angle Fixtured Tools	38, 39
Socket Trays	123	Angle Retractable Fixtured Tools	40-42
Test Fixtures	124	Inline Fixtured Tools	43, 44
Test Fixtures and Handles	125	Inline Retractable Fixtured Tools	45-48
Assembly Tool Definitions	128-132	Offset Retractable Fixtured Tools (3/4", 1")	49
B-Series Cordless Tools	57	Offset Retractable Fixtured Tools (2")	50
Pistol Grip Tools	60	Hold and Drive Fixtured Tools – 1" Output	51
Angle Head Tools	61-64	Limited Warranty Statement	133
Inline Tools	65	QBE Controllers	72
Tubenut / Crowfoot Tools	66	How to Order	73
Hold and Drive Tools	67	QBE Expert Controller	74
B-Series Cordless Tools Batteries	68	QBE Specialist Controller	76
Cable Options		QBE Advanced Controller	78
EB-Series	52	QBE Standard Plus Controller	80
E-Series	54	QBE Node Controller	81
Catalog Guide & How to Order	9	QBE Network Node Controller	82
Certification and Compliance	134	QB Spindle Disconnect Controllers	83
EB-Series: Reliability and Performance	11	Alpha Toolbox Software	84
		Sockets	
		Crowfoot/Tubenut Standard Sockets	92-101
		Flush Angle Standard Sockets	102-105
		Hold and Drive	106-117
		Tool Labeling Key	9
		Tool and Controller Safety	8

Global Sales and Support

Sales and Support North America

STANLEY Assembly Technologies USA
5335 Avion Park Drive
Cleveland, Ohio 44143-2328, USA
Tel: +1.440.461.5500 Fax: +1.440.461.5592
Email: SATinfo@sbdinc.com

Spain

STANLEY Engineered Fastening SPAIN
Avenida de Madrid, 35
28802 Alcalá de Henares (Madrid), Spain
Tel: +34 (91) 877-0380
Email: Felix.Barba@sbdinc.com

France

STANLEY Engineered Fastening FRANCE
Emhart Fastening and Assembly S.N.C.
Batiment Le Monet Paris Nord 2, 9 allée des Impressionnistes
CS 59328 Villepinte, 95941 Roissy CDG Cedex, France
Tel: +33 (1) 3050 9100 Fax: +33 (1) 3051 0708
Email: Vahid.Amirzadeh@sbdinc.com

Japan

STANLEY Engineered Fastening JAPAN
Hosoda, Noyori-cho, Toyohashi-shi
Aiti (Aichi) 441-8540, Japan
Tel: +81 0532.25.1126 Fax: +81 0532.25.1120
Email: Haruhiko.Suzuki@sbdinc.com

Sales and Support Americas /Asia-Pacific

STANLEY Assembly Technologies USA
2380 Meijer Drive, Troy, MI 48084, USA
Tel: +1.248.677.9709 Fax: +1.248.677.9923
Sales: 877.709.8006 Service: 877.787.7830
Email: SATinfo@sbdinc.com

European Headquarters

STANLEY Engineered Fastening GERMANY
Max-Eyth-Str. 1, 35394 Giessen, Germany
Tel: +49 (0) 641 405-728 Fax: +49 (0) 641 405 - 383
Email: Vahid.Amirzadeh@sbdinc.com

China

STANLEY Engineered Fastening CHINA
BUILDING NO. 9, 615 FENGDENG ROAD
MALU TOWN, JIADING DISTRICT
Shanghai 201801, China
Tel: +86 21.3915.5588-5511 Fax: +86 21.3915.5555
Email: Yi.Yu@sbdinc.com

India

STANLEY Engineered Fastening INDIA
6th Floor, Apex Towers, No 54, 2nd Main Road, R A Puram
CHENNAI – 600 028, India
Tel: +91 44 4343 7100 Fax: +91 44 4306 0768
Email: Rajesh.Patil@sbdinc.com

STANLEY
Engineered Fastening

Stanley Engineered Fastening — a division of Stanley Black and Decker — is the global leader in precision fastening and assembly solutions. Our industry-leading brands, Avdel®, Integra™, Nelson®, Optia™, POP®, STANLEY® Assembly Technologies, and Tucker®, elevate what our customers create. Backed by a team of passionate and responsive problem-solvers, we empower engineers who are changing the world.

STANLEY ENGINEERED FASTENING FAMILY OF BRANDS

AVDEL INTEGRA NELSON OPTIA POP STANLEY Assembly Technologies TUCKER