

POP[®]

INSTRUCTION MANUAL PRT 5250

Inline Blind Rivet Tool



EMHART[®]
TEKNOLOGIES

ATTENTION!
TO INSURE PROPER FUNCTIONING AND SAFE OPERATION
READ THIS MANUAL CAREFULLY BEFORE ATTEMPTING
TO OPERATE THIS TOOL.

SAFETY INSTRUCTIONS

1. Always wear **eye protection** when operating the PRT5250.
2. To avoid injury **do not point the tool at anyone.**
3. **Disconnect the tool from the air supply** when not in use for an extended period of time or before proceeding with any maintenance procedures.
4. **Do not attempt to operate the tool with the Nose Housing removed.** This exposes potential pinch points and could result in injury.
5. **Do not tamper with Clamp Screws or Fill Screw.** Loosened screws may result in a malfunction or injury due to air or hydraulic pressure.
6. **To avoid injury, keep the plug in the threaded open end of the Passageway Assembly when not using a Mandrel Collection System.**
7. **Always clear the tool of spent mandrels** before setting a new fastener.
8. **Passageway Fastening Screws should only be removed during tool maintenance.** The tool should not be operated with the Passageway Cover removed.
9. **Use caution when holding the tool at an angle** since compressed air is released through the Intensifier Chamber and may be directed towards the operator. Do not direct exhaust towards anyone.
10. Inspect the tool at regular intervals for damage and proper function. **Replace damaged parts immediately. Do not connect a damaged tool to an air supply.**
11. **Use only genuine Pop brand replacement parts.**

DESCRIPTION

The PRT5250 is a light weight air-hydraulic In-Line Rivet Tool developed for over-head assembly and designed to be used in an upright, nose-down position. It can be suspended with the use of a 5lb. tool balancer to simplify the operation of setting blind rivets of 1/8", 5/32" and 3/16" diameter. The PRT5250 comes fitted with a 3/16" nose-piece, but can easily be converted to accommodate 1/8" and 5/32" rivet nosepieces (included with tool) or a 3/32" nosepiece (can be ordered separately).

PACKED IN CARTON

Part Number	Part Name	Data
PRT5250	In-Line Rivet Tool	Fully assembled
PRT5200	Air Supply Hose Assembly	6 feet long
PRN414	Nosepiece	For 1/8" Open End Rivets
PRN514	Nosepiece	For 5/32" Open End Rivets
PRN614	Nosepiece	For 3/16" Open End Rivets – Installed on Tool
PRT5200-4	Mandrel Guide & Jaw Pusher Assembly	Use with 1/8" and 3/32" diameter Rivets
PRG540-127	Oil Replacement Screw	Use for hydraulic oil replacement
PRT5250-91	Hanger	Installed on Tool
	Instruction Manual & Warranty Card	

SPECIFICATIONS

WEIGHT:	3.9 lbs. (1.77 Kg.)
LENGTH:	15.63 in. (397 mm)
WIDTH:	4.44 in. (113 mm)
STROKE	.63 in. (16 mm)
PULLING FORCE:	1700 lb.f. (7556 N)
AIR PRESSURE:	85 P.S.I. (5.8 bar or KgF/cm ²) max.

THEORY OF OPERATION

When the tool is connected to an air supply and the Trigger Lever is operated, pressurized air pushes the air piston which acts on the hydraulic Ram Assembly. The hydraulic Ram Assembly forces hydraulic fluid from the reservoir in the handle into the main hydraulic bore where it moves the hydraulic piston together with the attached pulling mechanism rearward. As the pulling jaws move rearward they close on and grip the rivet mandrel and set the rivet.

When the trigger is released air at line pressure forces the hydraulic piston forward to the starting position. As the hydraulic piston moves forward the hydraulic fluid is also forced back returning the hydraulic fluid and air piston to the starting position. When the hydraulic piston is fully returned the broken rivet mandrel is released as the jaws are forced open again against the nosepiece.

If the tool is equipped with an MCS5000 Remote Vacuum Mandrel Collection System the mandrel will be drawn out of the tool through the Mandrel Passage and deposited in the collection container.

INSTALLATION

CAUTION: Do not connect air supply until all tool parts are properly installed and ready for operation.

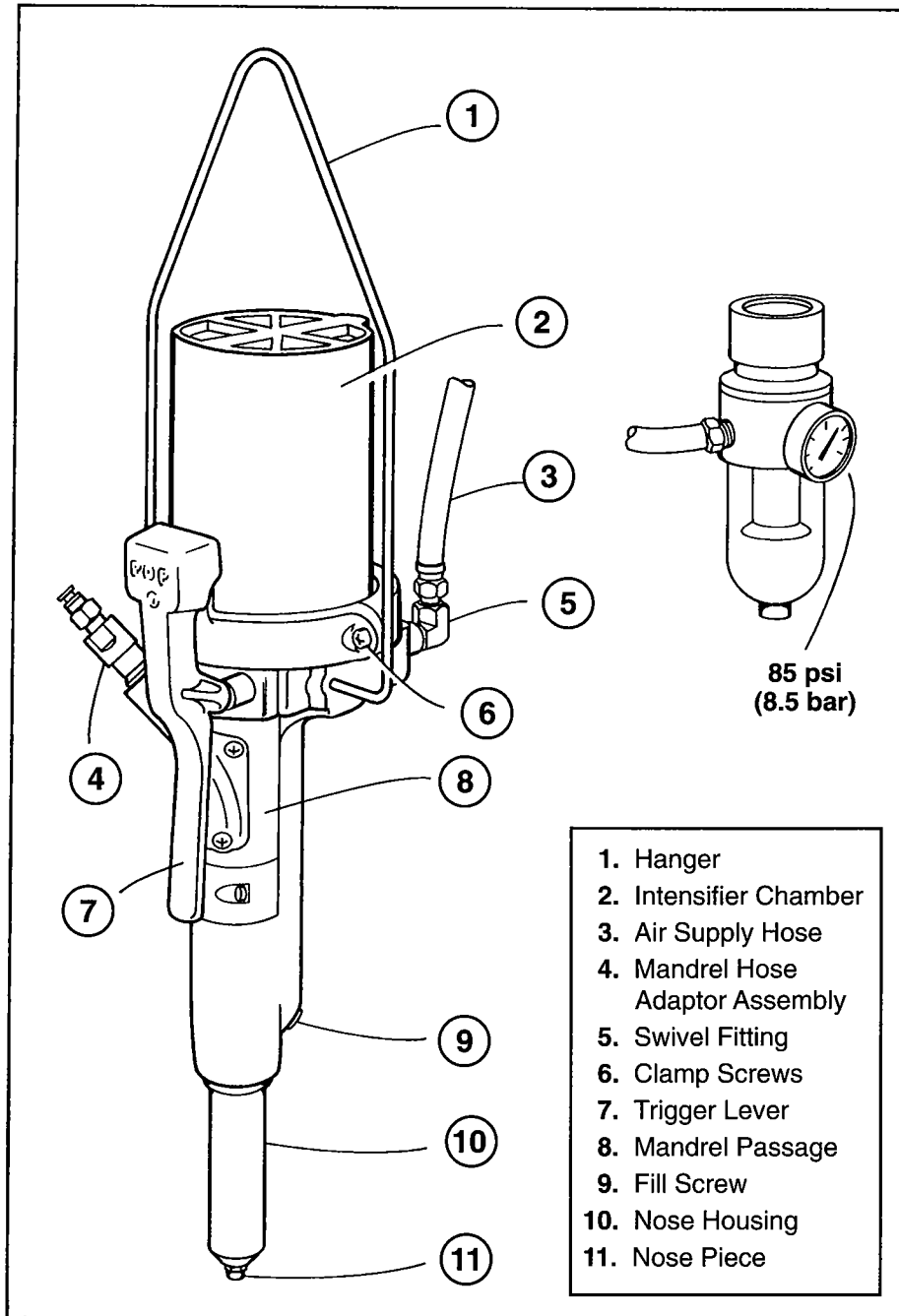

AIR SUPPLY REQUIREMENTS

1. Use a dry, filtered air supply regulated to 75 - 85 PSIG (5 - 6 BAR)
2. If using a Mandrel Collection System (MCS) with the PRT5250, a separate air supply should be used for each device. If both the PRT5250 and the MCS must be connected to the same air supply, a minimum of a 1/4" I.D. air supply hose is required to provide adequate volume.

PREPARING FOR OPERATION

1. Select and attach the appropriate Nosepiece based on the rivet size. The PRT5250 comes assembled with a 3/16" Nosepiece.

To change to a 5/32" Nosepiece, remove and replace the Nosepiece with part no. PRN514. Securely tighten.

When changing to the 1/8" Nosepiece, PRN414, installation of the Mandrel Guide and Jaw Pusher Assembly is required. Refer to Service Procedures, Section 1 for more information.

AVAILABLE NOSEPIECES

Rivet Size	Open End	Closed End Steel Mandrel	Closed End Aluminum Mandrel	T-Rivet
3/32"	PRN314			
1/8"	PRN414 *	PRN424	PRN434	
5/32"	PRN514 *	PRN524	PRN534	
3/16"	PRN614 *	PRN624	PRN634	PR25

* Included with the PRT5250
Additional parts listed above are available from POP Fasteners.
Specify part number when ordering.

2. Attach the air supply hose.

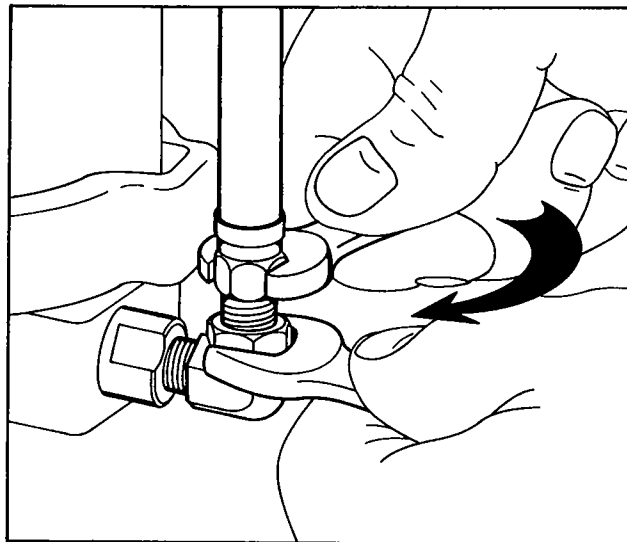

3. Attach the MCS5000 Mandrel Collection System.

Remove the plug from the threaded open end of the Passageway Assembly. (Leave this plug in place when not using a Mandrel Collection System and skip to step 4.)

Attach a Mandrel Hose Adapter Assembly to the tool and tighten gently. Select PRT5250-8 for 1/8" diameter rivets or PRT5250-9 (the larger of the two) for 5/32" or 3/16" diameter rivets.

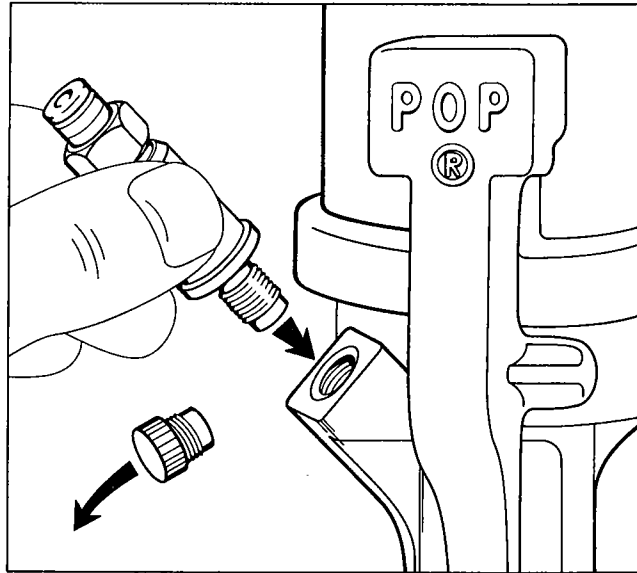

Insert one end of the Mandrel Collection Hose into the Mandrel Hose Adapter Assembly. Gently push until the hose is securely in place.

NOTE: To remove the collection hose from the adapter, gently push in on the red ring to release the hose from the self-gripping adapter.

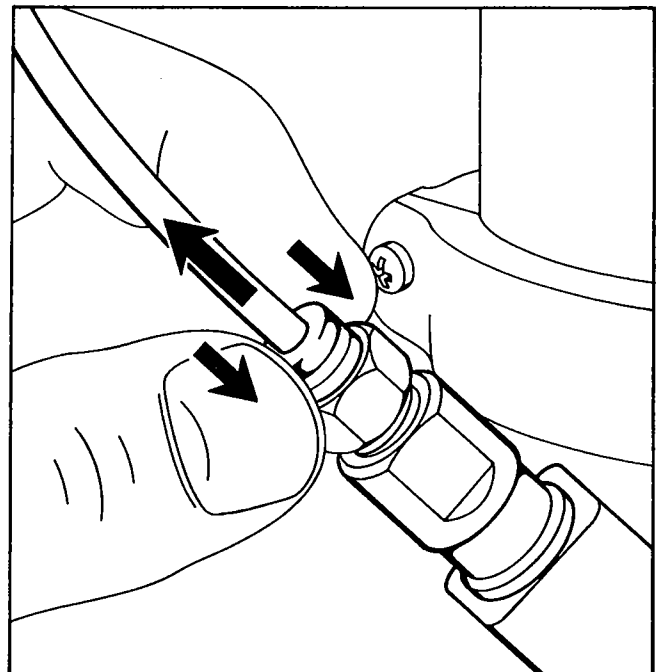
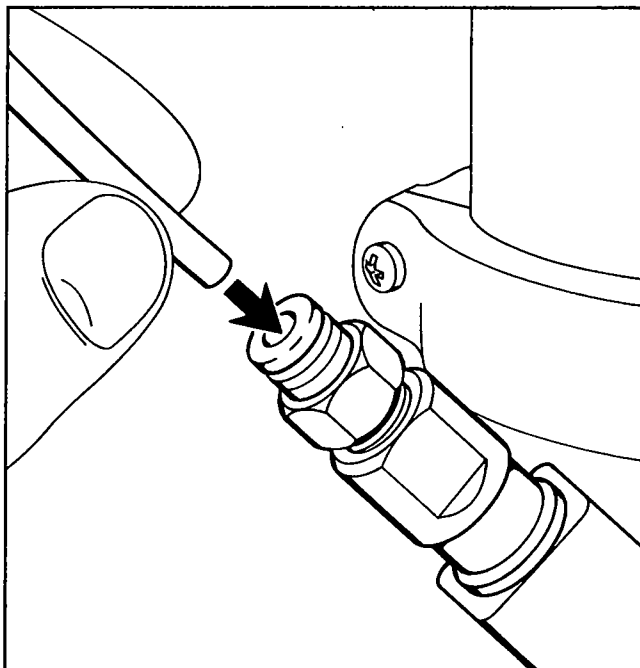

Insert the opposite end of the Mandrel Collection Hose into the hose fitting on the Mandrel Collection System. Gently push until the hose is securely in place.

4. Suspend the PRT5250 using the hanger attached to the tool. Use an adjustable **5lb. tool balancer or equivalent to position the tool.**
5. Attach the air supply hose on PRT5250 In-Line Rivet Tool to the air supply to begin operation.

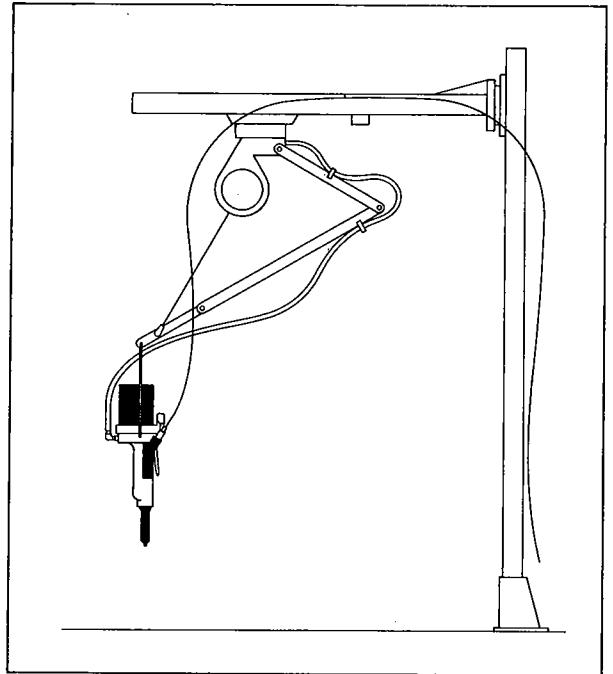

Tool Suspended From Tool Balancer

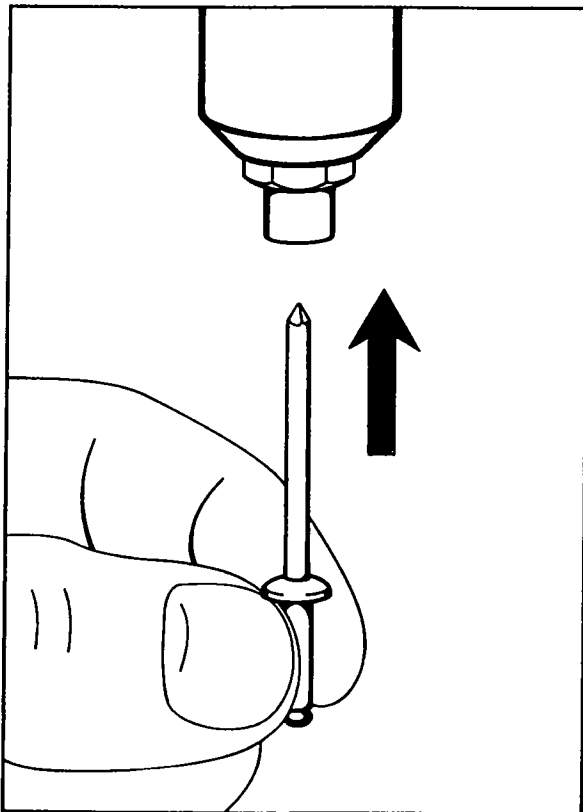

OPERATION

1. Once the tool is ready for operation, turn on the air supply to the PRT5250 and the Mandrel Collection System.
2. Insert a rivet mandrel into the Nosepiece as shown. The vacuum pull from the Mandrel Collection System holds the rivet securely in place.
3. Guide the tool until contact is made between the face of the rivet head and the outer surface of the unit to be riveted.
4. Squeeze the trigger lever on the side of the tool. Once the rivet is set, release the trigger lever. The spent mandrel is instantly propelled into the Mandrel Collection System bucket.

CAUTION: Do not point the tool toward anyone when riveting.

CARE AND MAINTENANCE

AIR SUPPLY REQUIREMENTS

Use only a filtered, dry air supply regulated between 75 to 85 PSIG (5-6 BAR) maximum pressure. No oiler is required or recommended on the air supply

SPECIFICATIONS FOR HYDRAULIC FLUID

POP Fasteners PRG540-130
Available in 1 quart containers

You can also use one of the following approved commercial equivalents:

Mobil	DTE26
Exxon	NUTO H-68
Shell	Tellus 68
Texaco	Rando HD-68

TOOLS AND EQUIPMENT REQUIRED

Hydraulic Oil
Oil Replacement Screw (3/8" - 24)
1" O.E. Wrench
Two 11/16" O.E. Wrenches
7/16" O.E. Wrench
Soft Jaw Vise
Phillips Screwdriver
Slotted Screwdriver

ROUTINE MAINTENANCE

1. Inspect the tool and air supply hose for damage daily. Replace damaged parts immediately.
2. Check and secure all fasteners daily.
3. Frequently clean, inspect and lubricate jaws, Jaw Guide and Jaw Pusher.
4. Keep Nose Housing, Nosepiece, and Jaw Guide tightened.
5. Frequently check vacuum Mandrel Collection System for efficiency.

SERVICE PROCEDURES

1. CHANGING SET UP FOR 1/8" DIAMETER RIVETS

To prevent mandrel jams from occurring inside the tool it is important to install a Jaw Pusher and Mandrel Guide Assembly when setting rivets 1/8" in diameter or smaller.

Parts needed: PRN414 Nosepiece
Jaw Pusher and Mandrel Guide Assembly, part no. PRT5200-4

Equipment needed: 7/16" O.E. Wrench
1" O.E. Wrench
Two 11/16" O.E. Wrenches
Soft-Jaw Vise

- a. Place the tool in a soft-jaw vise, gripping the tool near the front of the plastic passageway (about 2" back from the front of the aluminum casting).
- b. Remove the Nosepiece.
- c. Remove the Nose Housing.
- d. Remove the Jaw Guide, Jaws and Jaw Pusher. (Store the Jaw Pusher carefully. This part will be used again for larger size rivets).
- e. Insert the Mandrel Guide and Jaw Pusher Assembly into the Jaw Pusher Spring.
- f. Replace the Jaws and the Jaw Guide and tighten to 25-30 ft. lbs. torque.
- g. Replace the Nose Housing and wrench-tighten to 25 ft. lbs. torque.
- h. Attach the PRN414 Nosepiece and wrench-tighten to 60 in. lbs. torque.

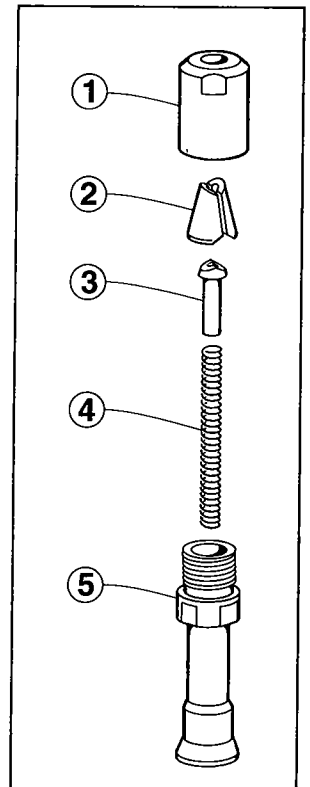
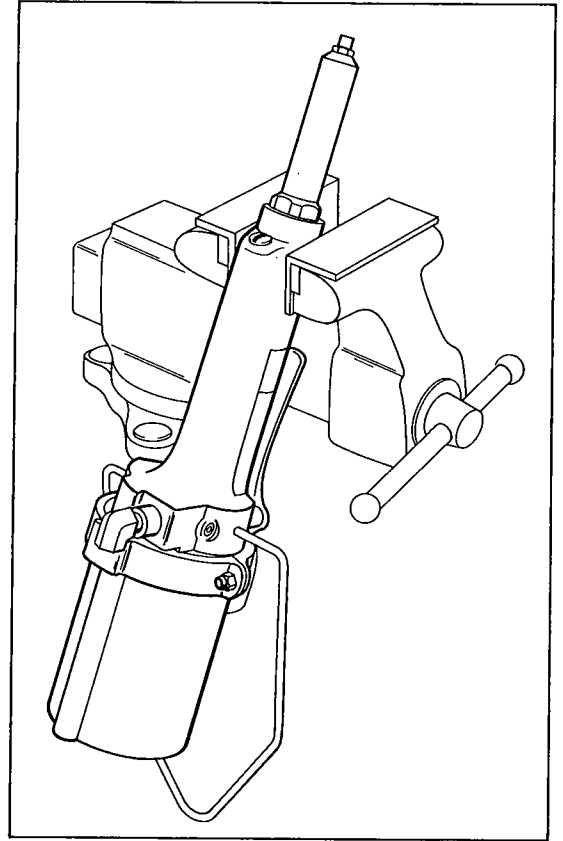

1. Jaw Guide
2. Jaws
3. Jaw Pusher
4. Jaw Pusher Spring
5. Pulling Head Adaptor

2. SERVICING THE JAWS, JAW PUSHER AND JAW PUSHER SPRING

Equipment Needed 1" O.E. Wrench.
 7/16" O.E. Wrench
 Two 11/16" O.E. Wrenches
 Soft-Jaw Vise
 Brushes & Cleaning Solvent

- a. Place the tool in a soft-jaw vise, gripping the tool near the front of the plastic passageway (about 2" back from the front of the aluminum casting). Refer to Section 1.
- b. Remove the Nosepiece and the Nose Housing.
- c. Loosen and unscrew the Jaw Guide.
- d. Tilt the tool to remove the Jaw Pusher Spring.
- e. Check for fatigued Jaw Pusher Spring. A new Jaw Pusher Spring measures 2 1/8" long. It will need to be replaced if shorter than 1 7/8 inches.
- f. With a soft brush and cleaning solvent, clean the serrated teeth of the Jaws. Using a wire brush, remove any dirt buildup inside the Nose Housing and behind the Nosepiece.
- g. Lightly oil Jaws and Jaw Pusher. Reassemble and attach to the Pulling Head Adapter. Wrench tighten to 25-30 ft. lbs. torque.
- h. Replace the Nose Housing and wrench tighten to 25 ft. lbs. torque.
- i. Replace the Nosepiece and securely tighten to 60 in. lbs. torque.

3. REPLACEMENT OF HYDRAULIC FLUID

A shortened stroke indicates minor oil loss.

Parts needed: Oil Replacement Screw, 3/8" – 24 Socket
 Head Cap Screw
 Hydraulic Oil

Equipment needed: Soft-Jaw Vise
 7/16" O.E. Wrench
 Slotted Screwdriver

- a. Place the tool in a soft-jaw vise, making sure the Fill Screw is facing up.
- b. Remove the Nosepiece, the Fill Screw and Seal Washer.
- c. To properly add oil, the Hydraulic Piston must be pushed back between 1/4" to 3/8" To do this, *simultaneously turn the Oil Replacement Screw into the Nose Housing (approximately 6 to 8 turns of the screw) while adding the oil one drop at a time through the Fill Screw opening.* Do not tighten the Oil Replacement Screw since internal tool damage may result. Allow bubbles to rise out of the oil.
- d. Reinstall Fill Screw and Seal Washer. Tighten securely.
- e. Remove the Oil Replacement Screw. Replace the Nosepiece and tighten securely.
- f. Reconnect the air supply.
- g. Loosen Fill Screw slightly, allowing excess oil to be forced out. **Do not depress the hand lever when Fill Screw is loose. This will cause oil to be forced out under great pressure.**
- h. Wipe tool clean and tighten Fill Screw securely.

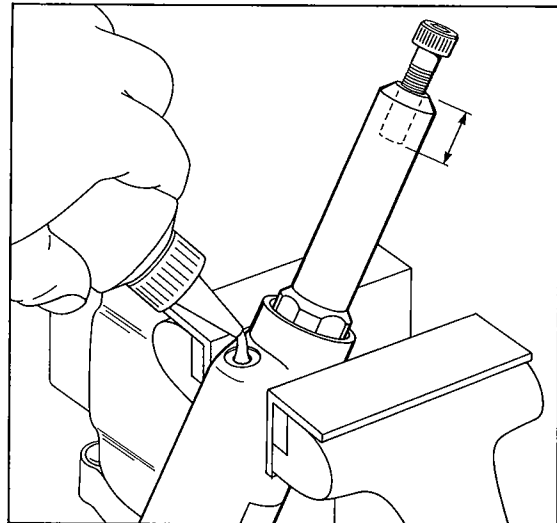

If oil loss is rapid or excessive refer to the service manual.

4. CLEARING MANDREL JAMS

Mandrel jams occur under these conditions: the tool has dirt and oil build-up, there is a kink or insufficient radius in the Mandrel Collection Hose, there is insufficient vacuum due to an air leak, low air pressure or dirt in the vacuum transducer or a bent mandrel could not pass through the collection hose.

- a. Inspect the radius of the Mandrel Collection Hose. A minimum 12" radius is required. Check the hose radius especially near the tool and collection unit and adjust as necessary. If this was the cause of the mandrel jam, the spent mandrel should now pass thru the Mandrel Collection Hose easily. Check the hose support to prevent kinks. If the hose has a kink cut off the kinked portion or replace the hose.
- b. If jammed mandrels are visible through the clear plastic cover of the Passageway Assembly, remove the two screws and clear cover and dislodge the jammed mandrels.

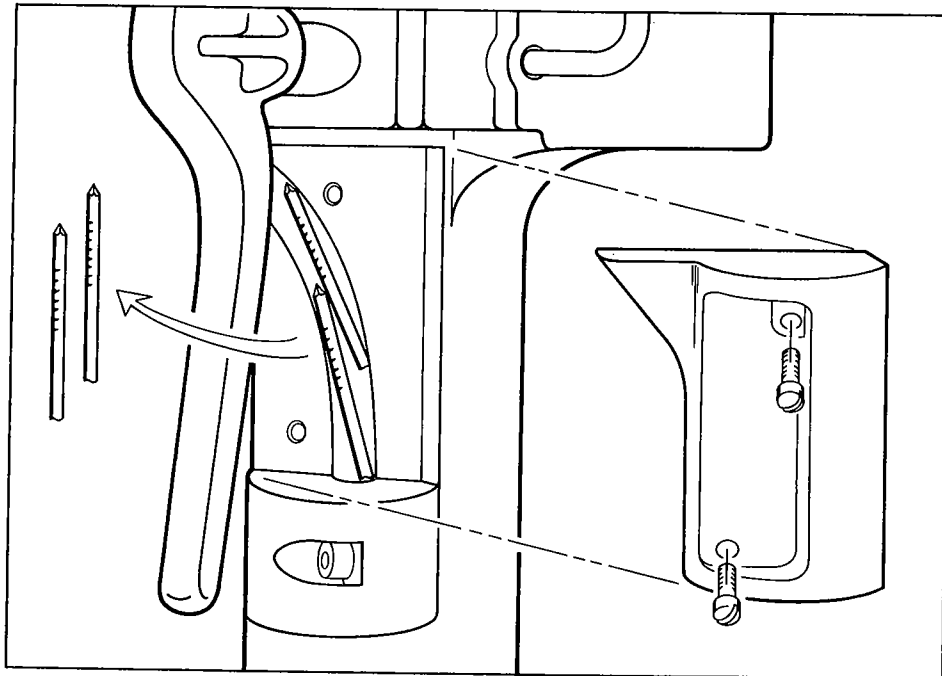

- c. Reinstall the screws and the clear plastic cover on the Passageway Assembly. This type of jam is usually the result of excess dirt and oil in the front end of the tool. Clean and lubricate the Jaws, Jaw Pusher and Jaw Pusher Spring. See section 2.
- d. Remove the Mandrel Hose Adaptor Assembly and make sure the openings are clear of dirt build-up.

5. SERVICING THE AIR SUPPLY HOSE

Periodically inspect the air hose for normal wear and tear. To replace a damaged hose:

- a. Disconnect hose from air supply.
- b. Disconnect the air hose with fitting from the swivel fitting.
- c. Repair as necessary.
- d. Check the 'O-clamps' and fittings at either end of the hose. Remove and replace as necessary.
- e. Reconnect the hose to the swivel fitting on the PRT5250. Securely tighten with a wrench.

Replacement Air Hose Parts are available from POP Fasteners.

TROUBLESHOOTING

CAUTION: Disconnect the air supply and the Mandrel Collection System (if so equipped) BEFORE starting any disassembly/assembly procedures.

Trouble	Probable Cause	Corrective Action
1. Tool will not operate.	Tool disconnected from air supply or air pressure too high.	Check air supply connection. Set air pressure to 85 psig.
2. Tool will not break rivet mandrel.	1. Jaws slipping on mandrels indicated by lack of tooth marks on mandrel. 2. Low air pressure.	Clean or replace Jaws, check Jaw Pusher Spring. See Section 2. Set air pressure at 85 psi.
3. Loss of stroke.	1. Jaws slipping on mandrels indicated by lack of tooth marks on mandrel. 2. Loss of hydraulic fluid.	Clean or replace Jaws, check Jaw Pusher Spring. See Section 2. Add hydraulic oil. See Section 3.
4. Mandrels sticking in Jaws.	1. Dirt packed inside nose housing, behind nosepiece or inside Jaw Guide. 2. Nosepiece loose. 3. Too much hydraulic fluid in tool.	Clean and lubricate all front end parts. See Section 2. Wrench tighten Nosepiece. Too much fluid was added during last fill. See Section 3, par. d through h.
5. Mandrels jammed in tool or Mandrel Hose.	1. Mandrel collection hose disconnected or kinked. 2. Passageway cover loose or seal is leaking. 3. Dirt buildup in mandrel passageway. 4. Jaw Pusher and Mandrel Guide Assembly not installed (required for 1/8" or smaller rivets). 5. Problem with Vacuum Transducer.	Check connections. Replace hose if kinked. See Section 4. Check cover seal, tighten cover screws. Clean mandrel passageway from nosepiece to Mandrel Hose Adaptor Assembly. See Service Procedure, Section 1. See MCS5000 Maintenance Manual.

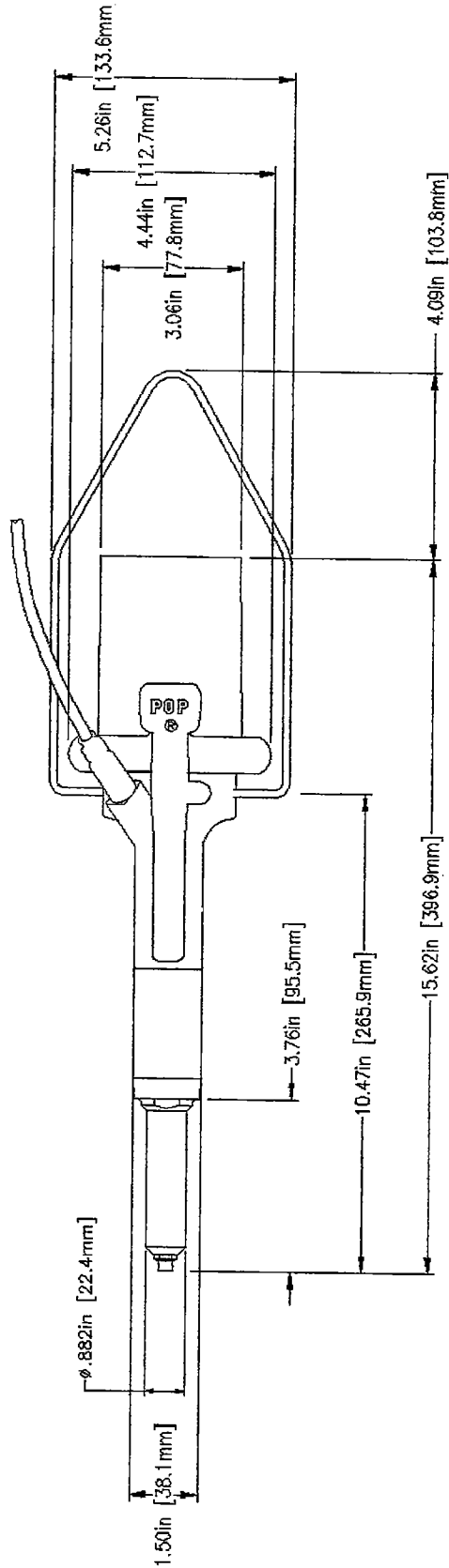

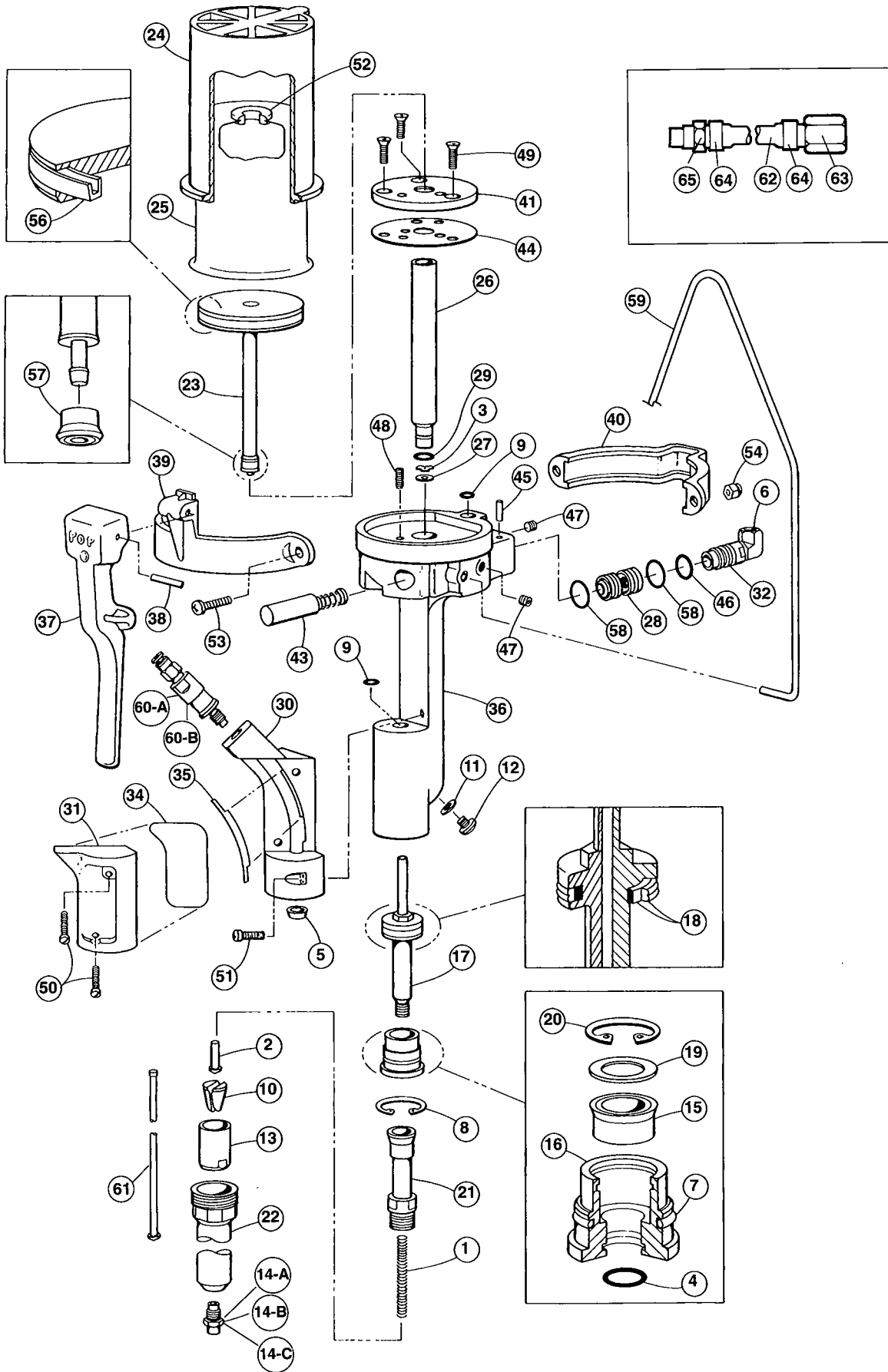

ITEM	PART NO.	DESCRIPTION	QTY	ITEM	PART NO.	DESCRIPTION	QTY
1	PRG510-123	Jaw Pusher Spring	1	36	PRT5250-31	Handle	1
2	PRG520-33	Jaw Pusher	1	37	PRT5250-32	Trigger Lever	1
3	PRG520-45	Restrictor	1	38	PRT5250-33	Lever Spring Pin	1
4	PRG520-47	O-Ring (Seal Sleeve Inside)	1	39	PRT5250-42	Rear Clamp	1
5	PRG-520-60	Passage Seal	1	40	PRT5250-43	Front Clamp	1
6	PRG520-68	Street Elbow (1/8-1/8 NPT)	1	41	PRT5250-48	Ram Sleeve Retainer Plate	1
7	PRG520-89	O-Ring (Seal Sleeve Outside)	1	42	PRT5250-49	Caution & Name Label (Not Shown)	1
8	PRG520-101	Sleeve Retainer Ring	1	43	PRT5250-50	Air Regulator Assembly	1
9	PRG520-106	O-Ring (Intensifier Chamber)	2	44	PRT5250-51	Retainer Plate Gasket	1
10	PRG540-46	Jaws	2	45	PRT5250-86	Swivel Spring Pin	1
11	PRG540-102	Fill Screw Washer	1	46	PRT5250-87	O-Ring (Swivel)	1
12	PRG540-122	Fill Screw	1	47	PRT5250-89	Pressure Plug	2
13	PRG740-11A	Jaw Guide	1	48	PRT5250-92	Mandrel Passage Screw	1
14A	PRN614	Nosepiece (3/16" Open End)	1	49	PRT5250-94	Retainer Plate Screw	3
14B	PRN514	Nosepiece (5/32" Open End)	1	50	PRT5250-96	Cover Screw	2
14C	PRN414	Nosepiece (1/8" Open End)	1	51	PRT5250-97	Mandrel Passage Screw	1
15	PRT5200-8	Rod Seal	1	52	PRT5300-26	Grommet	1
16	PRT5200-10	Seal Sleeve	1	53	PRT5500-112	Clamp Screw	2
17	PRT5200-14	Hydraulic Piston Rod	1	54	PRT5500-113	Clamp Nut	2
18	PRT5200-15	Piston Seal	1	55	PRT5250-70	Country of Origin Label (Not Shown)	1
19	PRT5200-19	Seal Retaining Washer	1	56	PRT5200-28	Air Piston Seal	1
20	PRT5200-20	Seal Snap Ring	1	57	PRT5200-84	Ram Seal	1
21	PRT5200-21	Pulling Head Adaptor	1	58	PRG540-117	O-Ring (Air Valve)	2
22	PRT5200-22	Nose Housing	1	59	PRT5250-91	Hanger	1
23	PRT5200-26	Intensifier Assembly (Includes Items 56 & 57)	1	60A	PRT5250-8	MCS Adaptor Assembly (1/8" Rivets)	1
24	PRT5200-29	Intensifier Chamber	1	60B	PRT5250-9	MCS Adaptor Assembly (5/32" & 3/16" Rivets)	1
25	PRT5200-30	Intensifier Chamber Sleeve	1	61	PRT5200-4	Mandrel Guide & Jaw Pusher Assembly (1/8" Rivets)	1
26	PRT5200-46	Ram Sleeve	1	62	PRG540-39	Air Line Hose	1
27	PRT5200-47	Restrictor Seat	1	63	PRG540-40	Female Fitting	1
28	PRT5200-55	Air Valve Assembly (Includes Item 58)	1	64	PRG540-45	Air Line "O" Clamp	2
29	PRT5200-59	O-Ring (Ram Sleeve)	1	65	PRT5200-90	Air Line Fitting	1
30	PRT5250-2	Mandrel Passage	1				
31	PRT5250-3	Passage Cover	1				
32	PRT5250-4	Air Line Swivel	1				
33	PRT5250-10	Safety Plug (Not Shown)	1				
34	PRT5250-11	O-Ring (Passage Cover)	1				
35	PRT5250-12	Mandrel Slide	1				

**Emhart Fastening Technologies
Industrial Division**

Headquarters:

510 River Road, P.O. Box 859
Shelton, CT 06484
Tel. (203) 924-4722
Fax (800) 732-3116

California Office & Warehouse

1402 McGaw
Irvine, CA 92614
Tel. (714) 851-2298
Fax (714) 851-2099

Canadian Office & Warehouse

3545 Thimens Boulevard
St. Laurent, Quebec, H4R 1V5
Tel. (514) 333-8080
Fax (514) 338-3829



A  **BLACK & DECKER** COMPANY

Instruction Manual

POP[®] Rivet Tools

Conversion Manual for PRT 5250A

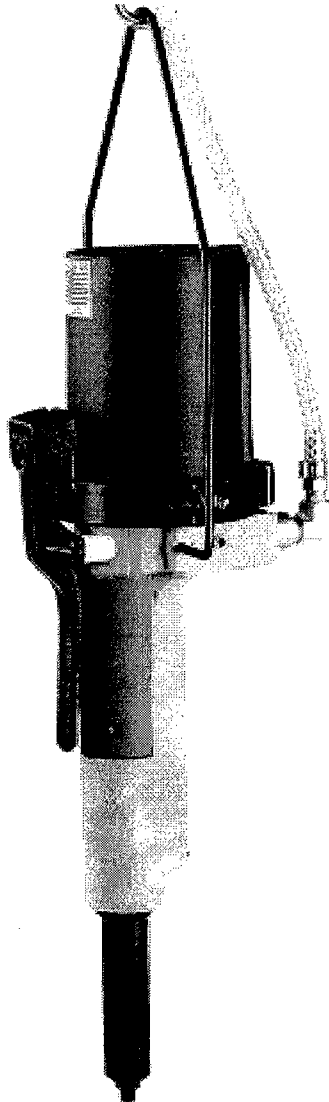

INSIDE

PRT 5250A ADDENDUM

<i>I. Remove Old Passage Components</i>	2
<i>II. Re-assemble Tools</i>	3
<i>III. New Mandrel Slide Assembly</i> ..	4
<i>IV. Clearing Mandrel Jam</i>	5
<i>Part Identification List</i>	7
<i>Component Overview</i>	Back Cover



A BLACK & DECKER COMPANY

I. REMOVE OLD PASSAGE COMPONENTS

For this section, refer to the PRT5250 Instruction Manual (P329) for item numbers and exploded view.

1. Remove Nose Housing (Item 22) and Seal Sleeve Retainer (Item 8).
2. Withdraw the Pulling Head Assembly so that the end of the Hydraulic Piston (Item 17) clears the Passage Body (Item 31). (See Figure 1)

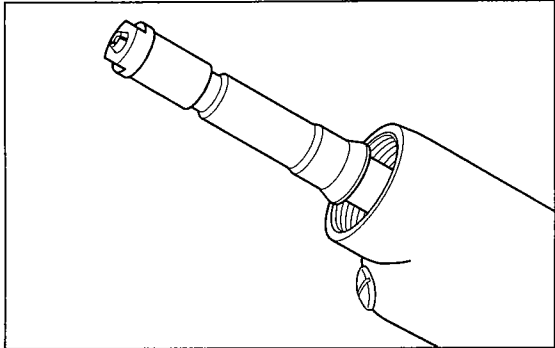

Figure 1

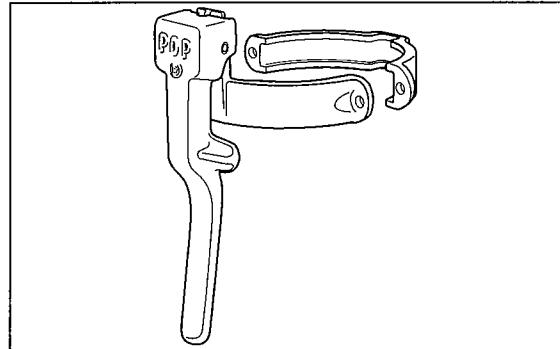

Figure 2

3. Remove the Front and Rear Clamps (Items 40 & 39). The Trigger-Lever (Item 37) is attached to the Rear Clamp (Item 39). (See Figure 2)
4. Remove Intensifier Pot Assembly (Ref. Items 24, 25 & 52), Intensifier Piston Assembly (Ref. Items 23, 56 & 57), and unscrew Set Screw (Item 48) until flush with surface of handle. (Item 36). (See Figure 3)

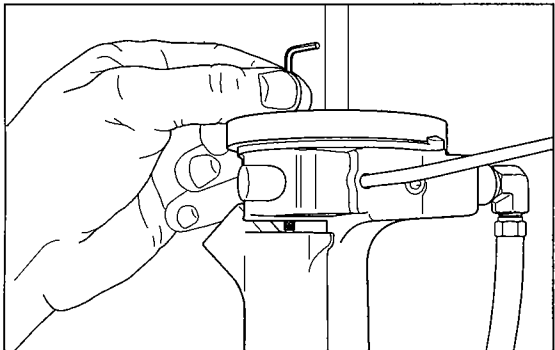

Figure 3

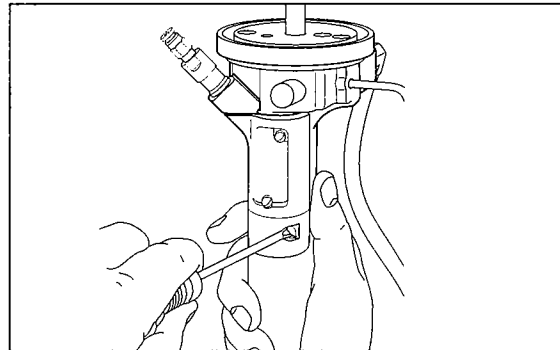

Figure 4

5. Remove Passage Mounting Screw (Item 51) and Existing Passage Assembly (Items 5, 30, 31, 34, 35, 50, 60A & 60B). (See Figure 4)

II. RE-ASSEMBLE TOOL AS DESCRIBED BELOW

For this section, refer to item numbers and exploded view in this manual. (PRT5250A Passage Conversion Kit Instruction Manual, document number P355).

1. Install the Pulling Head Assembly and secure it in place by installing the Seal Sleeve Retainer (Item 8). Be sure to examine Seal Sleeve O-ring (Item 7) and Piston Seal (Item 18) for damage before installing the Pulling Head Assembly. Replace any damaged seals first.
2. Assemble 2 O-rings (Item 50) on each end of the Seal Bushing (Item 3). (See Figure 5)

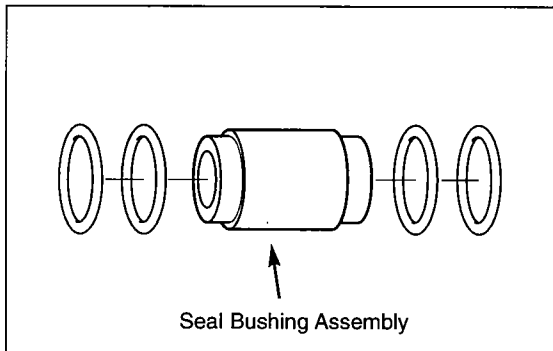

Figure 5

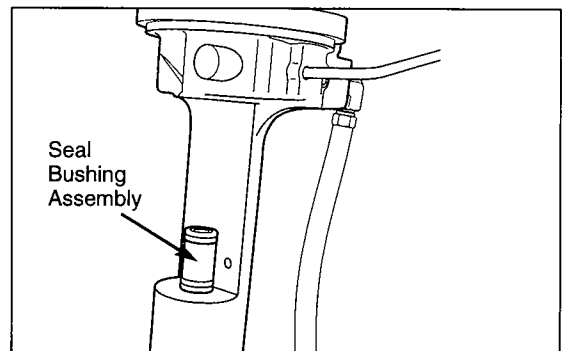

Figure 6

3. With tool in a horizontal or nose-down position, place the Seal Bushing Assembly over the exposed end of the Hydraulic Piston (Item 17). (See Figure 6)
4. Install the Passage Body (Item 30) onto the handle (Item 36). (See Figure 7) When installing the Passage Body, place the end that has the cut-out over the Seal Bushing Assembly trying not to compress the Seal Bushing O-rings (Item 50) at this time.

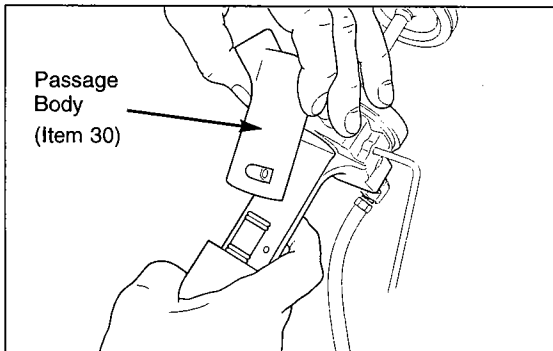

Figure 7

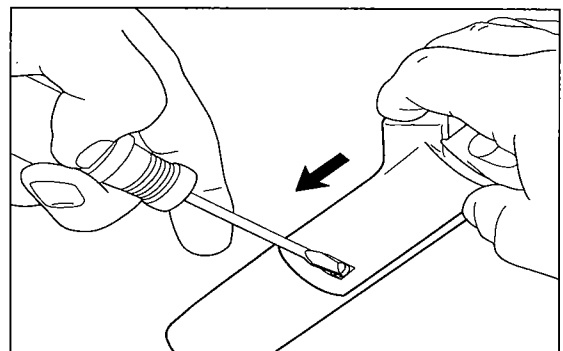

Figure 8

5. With the Passage Body (Item 30) bottom flush with the cut-out in the Handle (Item 36) apply force to the Passage Body in the direction of the tool nose. This will compress the Seal Bushing O-rings (Item 50) forming a face seal for the collection system. Install the Mandrel Passage Screw (Item 51) but do not tighten at this time. (See Figure 8)

II. RE-ASSEMBLE TOOL AS DESCRIBED BELOW (Continued)

6. Screw in the Passage Set Screw (Item 48) using a 3/32 hex key (allen wrench), being sure that it engages the recessed hole in the Passage Body (Item 30). (See Figure 9) Continue rotating the screw until it contacts the bottom of the recessed hole in the Passage Body, the Passage Body will begin to move forward. Continue rotating 1/2 turn and stop. Tighten Mandrel Passage Screw (Item 51). (Referring back to Figure 8 again)

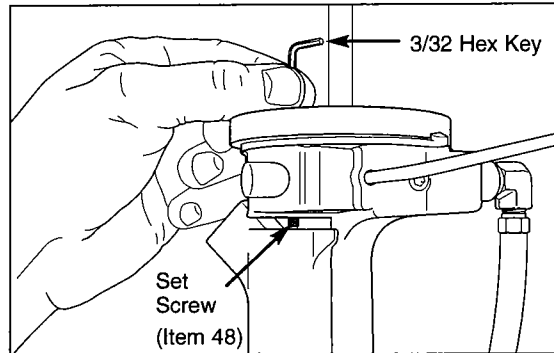

Figure 9

7. Recharge hydraulics.
 8. Install Intensifier Pot Assembly.
 9. Install Trigger-Lever Assembly.
 10. Assemble the Nosepiece to the vented-style Nose Housing (Item 22). (See Figure 10)
 11. Install the Nose Housing Assembly onto the tool.

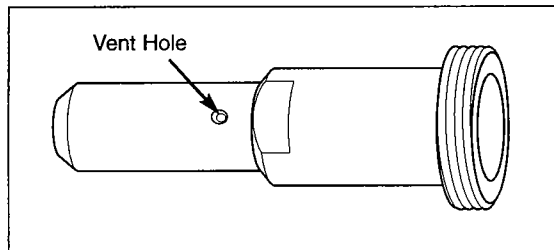

Figure 10

III. NEW MANDREL SLIDE ASSEMBLY

The Mandrel Slide can be set up for either 4-size (1/8") rivets or 5 & 6 size (5/32" & 3/16") rivets as follows.

- 1-A. To set up the Mandrel Slide for 4 size rivets, assemble the Slide (Item 35), Tapered Bushing for 1/8" rivets (Item 60A) and Fitting for 1/8" rivets (Item 34A). Parts should be orientated as shown.

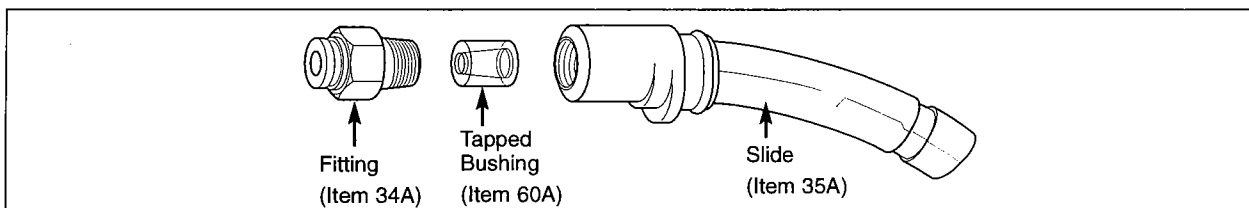

Figure 11

- 1-B. To set up the Mandrel Slide for 5 & 6 rivets, assemble the Slide (Item 35), Tapered Bushing for 5/32" and 3/16" rivets (Item 60B) and Fitting for 5/32" and 3/16" rivets (Item 34B). Parts should be orientated as shown.

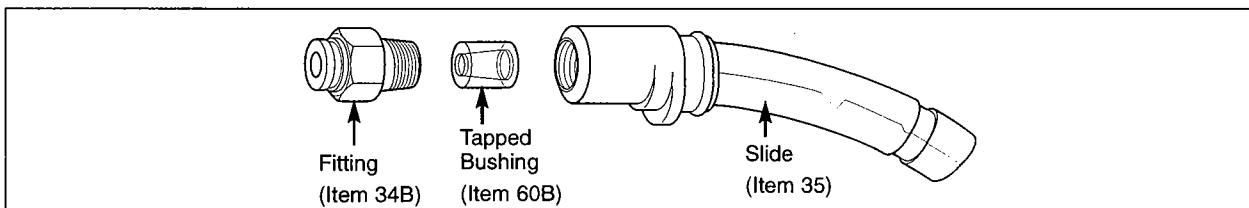

Figure 12

III. NEW MANDREL SLIDE ASSEMBLY (Continued)

2. Position the Strain Relief (Item 66) on the mandrel collection hose as shown and attach the hose to the Mandrel Slide Assembly. (See Figure 13) Slide the Strain Relief in place and push fit (while rotating clockwise) onto the Mandrel Slide Assembly.

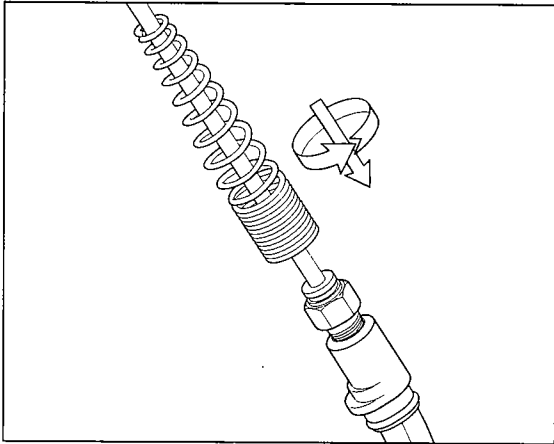

Figure 13

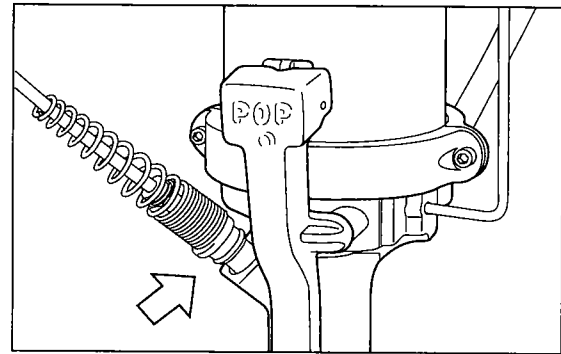

Figure 14

3. Insert the Mandrel Slide Assembly into the tool. (See Figure 14)

IV. CLEARING A MANDREL JAM

The PRT5250A POP® Rivetool is designed to allow easier clearing of any mandrel jams and to prevent jams from causing damage to the tool.

Proper tool maintenance, being aware of the position of your collection hose, and a constant filtered, dry air supply regulated between 75 to 85 PSIG (5-6 BAR) maximum pressure will minimize the occurrence of mandrel jams.

1. If mandrels accumulate in the passage area they will eventually push out the slide from the passage body (See Figure 15), interrupting the collection vacuum. The operator should notice less upward force when inserting rivets into the nosepiece and the rivet may not remain in the nosepiece without assistance.

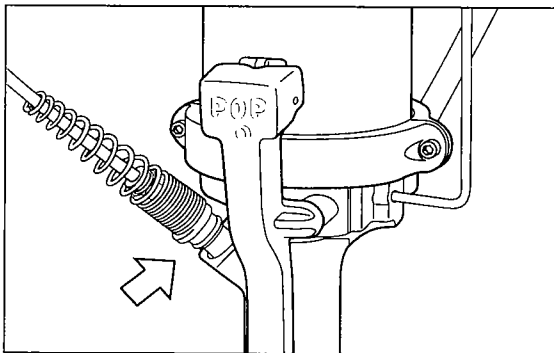

Figure 15

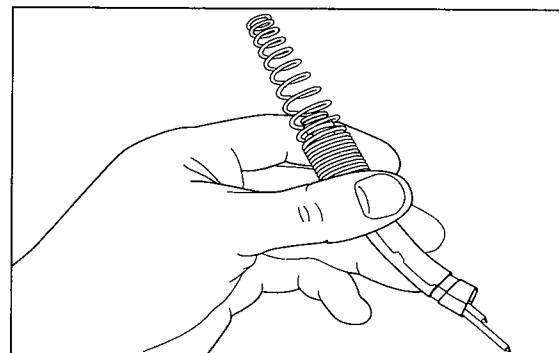

Figure 16

2. The slide should be removed completely to allow access to the mandrel jam. (See Figure 16)

IV. CLEARING A MANDREL JAM (Continued)

3. Tilt the slide and tool downward to remove any mandrels that may still be in the mandrel path. (See Figure 17)

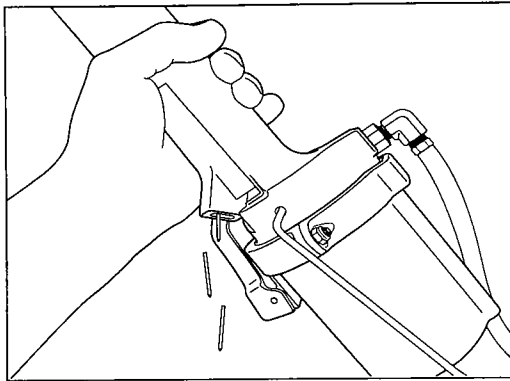

Figure 17

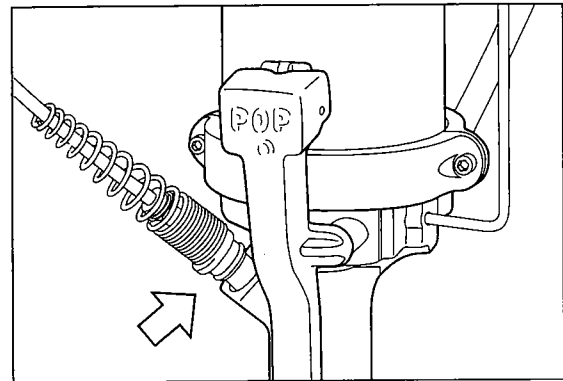

Figure 18

4. Re-attach the slide to the tool and resume work. (See Figure 18)

The POP® PRT5250A Rivetool should not be used in a horizontal position without a mandrel system in place.

When operating the POP® PRT5250A Rivetool in a nose-up position it is recommended that you install the Mandrel Slide Assembly and attach a collection hose in order to control the mandrel's exit from the tool.

**Model PRT5250A Rivet Tool
Part Identification List**

Item	Part No.	Description	Qty	Item	Part No.	Description	Qty
1	PRG510-123	Jaw Pusher Spring	1	35	PRT5250-82	Mandrel Slide	1
2	PRG520-33	Jaw Pusher	1	36	PRT5250-31	Handle	1
3	PRG520-45	Restrictor	1	37	PRT5250-32	Trigger Lever	1
4	PRG520-47	O-Ring (Seal Sleeve Inside)	1	38	PRT5250-33	Lever Spring Pin	1
5	PRT5250-27	O-Ring (Slide)	1	39	PRT5250-42	Rear Clamp	1
6	PRG520-68	Street Elbow (1/8-1/8 NPT)	1	40	PRT5250-43	Front Clamp	1
7	PRG520-89	O-Ring (Seal Sleeve Outside)	1	41	PRT5250-48	Ram Sleeve Retainer Plate	1
8	PRG520-101	Sleeve Retainer Ring	1	42	PRT5250-49	Caution & Name Label (Not Shown)	1
9	PRG520-106	O-Ring (Intensifier Chamber)	2	43	PRT5250-50	Air Regulator Assembly	1
10	PRG540-46	Jaws	2	44	PRT5250-52	O-Ring	1
11	PRG540-102	Fill Screw Washer	1	45	PRT5250-86	Swivel Spring Pin	1
12	PRG540-122	Fill Screw	1	46	PRT5250-87	O-Ring (Swivel)	1
13	PRG740-11A	Jaw Guide	1	47	PRT5250-89	Pressure Plug	2
14A	PRN614	Nosepiece (3/16" Open End)	1	48	PRT5250-92	Mandrel Passage Screw	1
14B	PRN514	Nosepiece (5/32" Open End)	1	49	PRT5250-94	Retainer Plate Screw	3
14C	PRN414	Nosepiece (1/8" Open End)	1	50	PRT5250-25	O-Ring (Seal Bushing)	4
15	PRT5200-8	Rod Seal	1	51	PRT5250-97	Mandrel Passage Screw	1
16	PRT5200-10	Seal Sleeve	1	52	PRT5300-26	Grommet	1
17	PRT5200-14	Hydraulic Piston Rod	1	53	PRT5500-112	Clamp Screw	2
18	PRT5200-15	Piston Seal	1	54	PRT5500-113	Clamp Nut	2
19	PRT5200-19	Seal Retaining Washer	1	55	PRT5250-70	Country of Origin Label (Not Shown)	1
20	PRT5200-20	Seal Snap Ring	1	56	PRT5200-28	Air Piston Seal	1
21	PRT5200-21	Pulling Head Adapter	1	57	PRT5200-84	Ram Seal	1
22	PRT5250-22	Nose Housing (vented)	1	58	PRG540-117	O-Ring (Air Valve)	2
23	PRT5200-26	Intensifier Assembly (Includes Items 56 & 57)	1	59	PRT5250-91	Hanger	1
24	PRT5200-29	Intensifier Chamber	1	60A	PRT5250-24	Tapered Bushing (1/8" Rivets)	1
25	PRT5200-30	Intensifier Chamber Sleeve	1	60B	PRT5250-26	Tapered Bushing (5/32" & 3/16" Rivets)	1
26	PRT5200-46	Ram Sleeve	1	61	PRT5200-4	Mandrel Guide & Jaw Pusher Assembly (1/8" Rivets)	1
27	PRT5200-47	Restrictor Seat	1	62	PRG540-39	Air Line Hose	1
28	PRT5200-55	Air Valve Assembly (Includes Item 58)	1	63	PRG540-40	Female Fitting	1
29	PRT5200-59	O-Ring (Ram Sleeve)	1	64	PRG540-45	Air Line "O" Clamp	2
30	PRT5250-28	Passage Body	1	65	PRT5200-90	Air Line Fitting	1
31	PRT5250-23	Seal Bushing	1	66	MCS5000-81	Strain Relief	1
32	PRT5250-4	Air Line Swivel	1				
33	PRT5200-220	Air Line Assembly	1				
34A	PRT5250-99	Fitting (1/8 Rivets)	1				
34B	PRT5250-98	Fitting (5/32 & 3/16 Rivets)	1				

Model PRT5250A

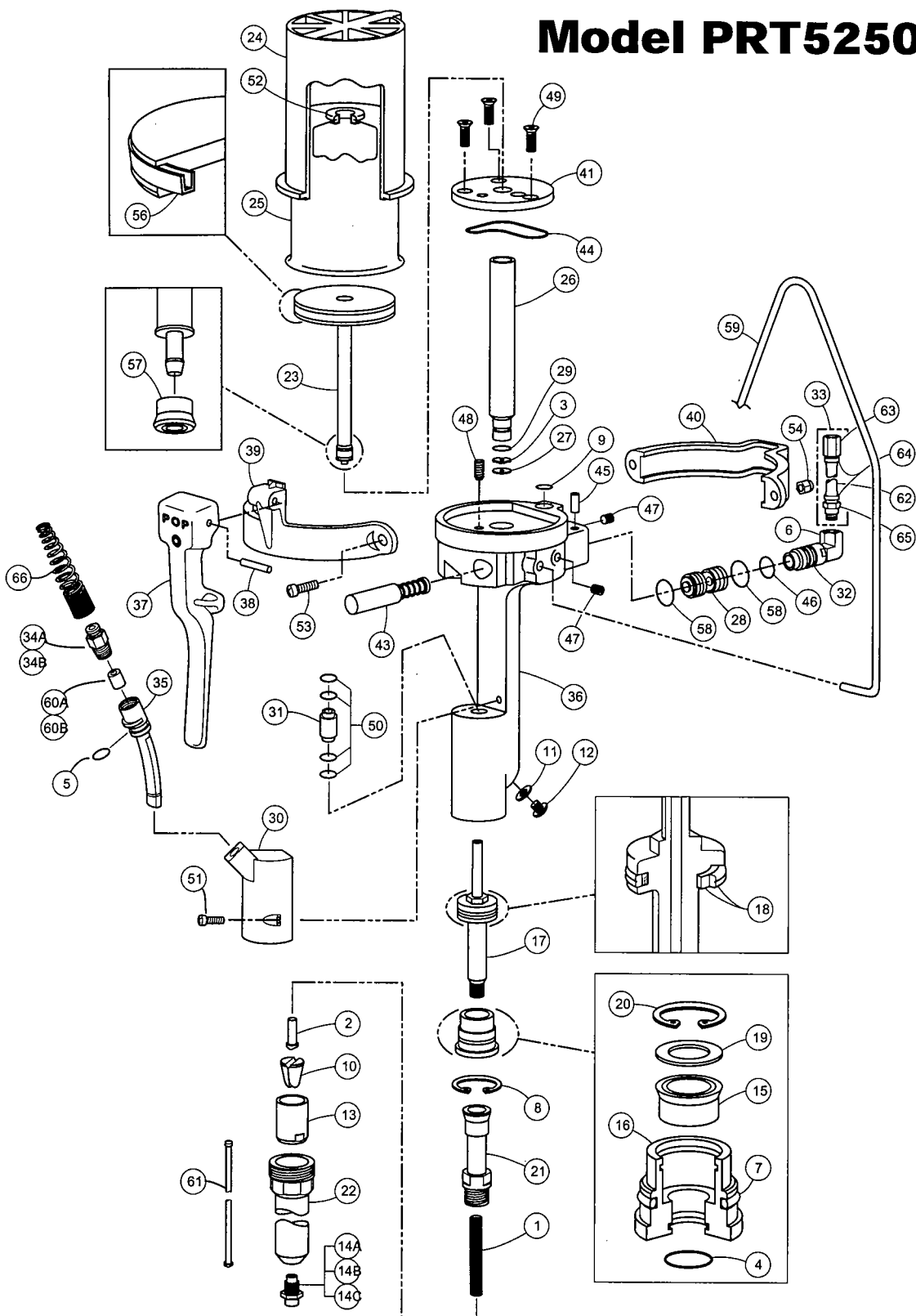

Emhart Fastening Technologies

510 River Road, P.O. Box 859
Shelton, CT 06484
Tel. (203) 924-9341
Fax (203) 925-3109

California Office & Warehouse
1402 McGaw
Irvine, CA 92614
Tel. (949) 851-2298
Fax (949) 851-2099

Canadian Office & Warehouse
9870 boul. du Golf
Anjou, Quebec, H1J 2Y7
Tel. (514) 351-0330
Fax (514) 351-0459

Mexico
Bosque de Radiatas No. 42
Col. Bosques de las Lomas
05120 México, D.F.
Tel. (52-5) 326-71-00
Fax (52-5) 326-71-41

Brazil
REFAL
Rua Ricardo Cavatton, 226
CEP 05038-110 São Paulo SP
Tel. (011) 861-3586
Fax (011) 861-3505



PRINTED IN U.S.A.

® Reg. U.S. Pat. Off.

P329A Addendum (02/02)

Visit our Website @ www.emhart.com

A BLACK & DECKER COMPANY

POP[®]

Blind Rivets

Emhart Teknologies

USA Office

50 Shelton Technology Center
Shelton, CT 06484
Tel: 877-EMHART-1
FAX: 800-225-5614

Canada Office

9870 Boulevard du Golf
Anjou, Quebec Canada
Tel: 514-351-0330
FAX: 514-351-0458

Mexico Office

Av. Antonio Dovali Jaime No 70
Torre B Piso 9
La Fe, Santa Fe
Mexico, D.F. 01210
Tel: 52-55-5326-7100
FAX: 52-55-5236-7141

www.emhartamericas.com

© Emhart Teknologies

P329A (01/12)

EMHART[®]
TEKNOLOGIES

A StanleyBlack&Decker, Inc. Company