

PRO  **WELD**
INTERNATIONAL

L.D. ARC GUN
AG-800/801



OPERATION/MAINTENANCE
MANUAL

TABLE OF CONTENTS

1.0	INTRODUCTION.....	1
2.0	WARRANTY.....	1
3.0	SUGGESTED SAFETY PRECAUTION.....	1
4.0	GENERAL DESCRIPTION.....	2
5.0	UNPACKING.....	2
6.0	GUN SET-UP.....	3
7.0	WELD TEST AND INSPECTION.....	5
7.1	WELD TEST.....	5
7.2	WELD INSPECTION.....	5
7.3	CAUSES OF POOR OR ERRATIC WELDS.....	5
7.4	TROUBLE SHOOTING POOR WELDS.....	7
8.0	MAINTENANCE.....	7
8.1	DISASSEMBLY.....	7
8.2	RE-ASSEMBLY.....	7
8.3	WELD CABLE REPLACEMENT.....	8
8.4	CONTROL CABLE REPLACEMENT.....	8
8.5	GUN MAINTENANCE.....	8
	PARTS LIST GUN ASSEMBLY ARC STD. LD.....	9,10
9.0	TROUBLE SHOOTING GUIDE.....	11

SECTION 1 – SAFETY PRECAUTIONS - READ BEFORE USING

1-1. Symbol Usage



Means Warning! Watch Out! There are possible hazards with this procedure! The possible hazards are shown in the adjoining symbols.

▲ Marks a special safety message.

☞ Means "Note"; not safety related.



This group of symbols means Warning! Watch Out! possible ELECTRIC SHOCK, MOVING PARTS, and HOT PARTS hazards. Consult symbols and related instructions below for necessary actions to avoid the hazards.

1-2. Arc Welding Hazards

▲ The symbols shown below are used throughout this manual to call attention to and identify possible hazards. When you see the symbol, watch out, and follow the related instructions to avoid the hazard. The safety information given below is only a summary of the more complete safety information found in the Safety Standards listed in Section NO TAG. Read and follow all Safety Standards.

▲ Only qualified persons should install, operate, maintain, and repair this unit.

▲ During operation, keep everybody, especially children, away.



ELECTRIC SHOCK can kill.

Touching live electrical parts can cause fatal shocks or severe burns. The electrode and work circuit is electrically live whenever the output is on. The input power circuit and machine internal circuits are also live when power is on. In semiautomatic or automatic wire welding, the wire, wire reel, drive roll housing, and all metal parts touching the welding wire are electrically live. Incorrectly installed or improperly grounded equipment is a hazard.

- Do not touch live electrical parts.
- Wear dry, hole-free insulating gloves and body protection.
- Insulate yourself from work and ground using dry insulating mats or covers big enough to prevent any physical contact with the work or ground.
- Do not use AC output in damp areas, if movement is confined, or if there is a danger of falling.
- Use AC output ONLY if required for the welding process.
- If AC output is required, use remote output control if present on unit.
- Disconnect input power or stop engine before installing or servicing this equipment. Lockout/tagout input power according to OSHA 29 CFR 1910.147 (see Safety Standards).
- Properly install and ground this equipment according to its Owner's Manual and national, state, and local codes.
- Always verify the supply ground – check and be sure that input power cord ground wire is properly connected to ground terminal in disconnect box or that cord plug is connected to a properly grounded receptacle outlet.
- When making input connections, attach proper grounding conductor first – double-check connections.
- Frequently inspect input power cord for damage or bare wiring – replace cord immediately if damaged – bare wiring can kill.
- Turn off all equipment when not in use.
- Do not use worn, damaged, undersized, or poorly spliced cables.
- Do not drape cables over your body.

- If earth grounding of the workpiece is required, ground it directly with a separate cable – do not use work clamp or work cable.
- Do not touch electrode if you are in contact with the work, ground, or another electrode from a different machine.
- Use only well-maintained equipment. Repair or replace damaged parts at once. Maintain unit according to manual.
- Wear a safety harness if working above floor level.
- Keep all panels and covers securely in place.
- Clamp work cable with good metal-to-metal contact to workpiece or worktable as near the weld as practical.
- Insulate work clamp when not connected to workpiece to prevent contact with any metal object.
- Do not connect more than one electrode or work cable to any single weld output terminal.

SIGNIFICANT DC VOLTAGE exists after removal of input power on inverters.

- Turn Off inverter, disconnect input power, and discharge input capacitors according to instructions in Maintenance Section before touching any parts.



FUMES AND GASES can be hazardous.

Welding produces fumes and gases. Breathing these fumes and gases can be hazardous to your health.

- Keep your head out of the fumes. Do not breathe the fumes.
- If inside, ventilate the area and/or use exhaust at the arc to remove welding fumes and gases.
- If ventilation is poor, use an approved air-supplied respirator.
- Read the Material Safety Data Sheets (MSDSs) and the manufacturer's instructions for metals, consumables, coatings, cleaners, and degreasers.
- Work in a confined space only if it is well ventilated, or while wearing an air-supplied respirator. Always have a trained watch-person nearby. Welding fumes and gases can displace air and lower the oxygen level causing injury or death. Be sure the breathing air is safe.
- Do not weld in locations near degreasing, cleaning, or spraying operations. The heat and rays of the arc can react with vapors to form highly toxic and irritating gases.
- Do not weld on coated metals, such as galvanized, lead, or cadmium plated steel, unless the coating is removed from the weld area, the area is well ventilated, and if necessary, while wearing an air-supplied respirator. The coatings and any metals containing these elements can give off toxic fumes if welded.



ARC RAYS can burn eyes and skin.

Arc rays from the welding process produce intense visible and invisible (ultraviolet and infrared) rays that can burn eyes and skin. Sparks fly off from the weld.

- Wear a welding helmet fitted with a proper shade of filter to protect your face and eyes when welding or watching (see ANSI Z49.1 and Z87.1 listed in Safety Standards).
- Wear approved safety glasses with side shields under your helmet.
- Use protective screens or barriers to protect others from flash and glare; warn others not to watch the arc.
- Wear protective clothing made from durable, flame-resistant material (leather and wool) and foot protection.



WELDING can cause fire or explosion.

Welding on closed containers, such as tanks, drums, or pipes, can cause them to blow up. Sparks can fly off from the welding arc. The flying sparks, hot workpiece, and hot equipment can cause fires and burns. Accidental contact of electrode to metal objects can cause sparks, explosion, overheating, or fire. Check and be sure the area is safe before doing any welding.

- Protect yourself and others from flying sparks and hot metal.
- Do not weld where flying sparks can strike flammable material.
- Remove all flammables within 35 ft (10.7 m) of the welding arc. If this is not possible, tightly cover them with approved covers.
- Be alert that welding sparks and hot materials from welding can easily go through small cracks and openings to adjacent areas.
- Watch for fire, and keep a fire extinguisher nearby.
- Be aware that welding on a ceiling, floor, bulkhead, or partition can cause fire on the hidden side.
- Do not weld on closed containers such as tanks, drums, or pipes, unless they are properly prepared according to AWS F4.1 (see Safety Standards).
- Connect work cable to the work as close to the welding area as practical to prevent welding current from traveling long, possibly unknown paths and causing electric shock and fire hazards.
- Do not use welder to thaw frozen pipes.
- Remove stick electrode from holder or cut off welding wire at contact tip when not in use.
- Wear oil-free protective garments such as leather gloves, heavy shirt, cuffless trousers, high shoes, and a cap.
- Remove any combustibles, such as a butane lighter or matches, from your person before doing any welding.

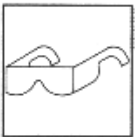

FLYING METAL can injure eyes.

- Welding, chipping, wire brushing, and grinding cause sparks and flying metal. As welds cool, they can throw off slag.
- Wear approved safety glasses with side shields even under your welding helmet.



BUILDUP OF GAS can injure or kill.

- Shut off shielding gas supply when not in use.
- Always ventilate confined spaces or use approved air-supplied respirator.



HOT PARTS can cause severe burns.

- Do not touch hot parts bare handed.
- Allow cooling period before working on gun or torch.



MAGNETIC FIELDS can affect pacemakers.

- Pacemaker wearers keep away.
- Wearers should consult their doctor before going near arc welding, gouging, or spot welding operations.



NOISE can damage hearing.

Noise from some processes or equipment can damage hearing.

- Wear approved ear protection if noise level is high.



CYLINDERS can explode if damaged.

Shielding gas cylinders contain gas under high pressure. If damaged, a cylinder can explode. Since gas cylinders are normally part of the welding process, be sure to treat them carefully.

- Protect compressed gas cylinders from excessive heat, mechanical shocks, slag, open flames, sparks, and arcs.
- Install cylinders in an upright position by securing to a stationary support or cylinder rack to prevent falling or tipping.
- Keep cylinders away from any welding or other electrical circuits.
- Never drape a welding torch over a gas cylinder.
- Never allow a welding electrode to touch any cylinder.
- Never weld on a pressurized cylinder – explosion will result.
- Use only correct shielding gas cylinders, regulators, hoses, and fittings designed for the specific application; maintain them and associated parts in good condition.
- Turn face away from valve outlet when opening cylinder valve.
- Keep protective cap in place over valve except when cylinder is in use or connected for use.
- Read and follow instructions on compressed gas cylinders, associated equipment, and CGA publication P-1 listed in Safety Standards.

1-3. Additional Symbols for Installation, Operation, and Maintenance



FIRE OR EXPLOSION hazard.

- Do not install or place unit on, over, or near combustible surfaces.
- Do not install unit near flammables.
- Do not overload building wiring – be sure power supply system is properly sized, rated, and protected to handle this unit.



MOVING PARTS can cause injury.

- Keep away from moving parts such as fans.
- Keep all doors, panels, covers, and guards closed and securely in place.



FALLING UNIT can cause injury.

- Use lifting eye to lift unit only, NOT running gear, gas cylinders, or any other accessories.
- Use equipment of adequate capacity to lift and support unit.
- If using lift forks to move unit, be sure forks are long enough to extend beyond opposite side of unit.



H.F. RADIATION can cause interference.

- High-frequency (H.F.) can interfere with radio navigation, safety services, computers, and communications equipment.
- Have only qualified persons familiar with electronic equipment perform this installation.
- The user is responsible for having a qualified electrician promptly correct any interference problem resulting from the installation.
- If notified by the FCC about interference, stop using the equipment at once.
- Have the installation regularly checked and maintained.
- Keep high-frequency source doors and panels tightly shut, keep spark gaps at correct setting, and use grounding and shielding to minimize the possibility of interference.



OVERUSE can cause OVERHEATING

- Allow cooling period; follow rated duty cycle.
- Reduce current or reduce duty cycle before starting to weld again.
- Do not block or filter airflow to unit.



STATIC (ESD) can damage PC boards.

- Put on grounded wrist strap BEFORE handling boards or parts.
- Use proper static-proof bags and boxes to store, move, or ship PC boards.



MOVING PARTS can cause injury.

- Keep away from moving parts.
- Keep away from pinch points such as drive rolls.



WELDING WIRE can cause injury.

- Do not press gun trigger until instructed to do so.
- Do not point gun toward any part of the body, other people, or any metal when threading welding wire.



ARC WELDING can cause interference.

- Electromagnetic energy can interfere with sensitive electronic equipment such as computers and computer-driven equipment such as robots.
- Be sure all equipment in the welding area is electromagnetically compatible.
- To reduce possible interference, keep weld cables as short as possible, close together, and down low, such as on the floor.
- Locate welding operation 100 meters from any sensitive electronic equipment.
- Be sure this welding machine is installed and grounded according to this manual.
- If interference still occurs, the user must take extra measures such as moving the welding machine, using shielded cables, using line filters, or shielding the work area.

1-4. Principal Safety Standards

Safety in Welding and Cutting, ANSI Standard Z49.1, from American Welding Society, 550 N.W. LeJeune Rd, Miami FL 33126

Safety and Health Standards, OSHA 29 CFR 1910, from Superintendent of Documents, U.S. Government Printing Office, Washington, D.C. 20402.

Recommended Safe Practices for the Preparation for Welding and Cutting of Containers That Have Held Hazardous Substances, American Welding Society Standard AWS F4.1, from American Welding Society, 550 N.W. LeJeune Rd, Miami, FL 33126

National Electrical Code, NFPA Standard 70, from National Fire Protection Association, Batterymarch Park, Quincy, MA 02269.

Safe Handling of Compressed Gases in Cylinders, CGA Pamphlet P-1, from Compressed Gas Association, 1235 Jefferson Davis Highway, Suite 501, Arlington, VA 22202.

Code for Safety in Welding and Cutting, CSA Standard W117.2, from Canadian Standards Association, Standards Sales, 178 Rexdale Boulevard, Rexdale, Ontario, Canada M9W 1R3.

Safe Practices For Occupation And Educational Eye And Face Protection, ANSI Standard Z87.1, from American National Standards Institute, 1430 Broadway, New York, NY 10018.

Cutting And Welding Processes, NFPA Standard 51B, from National Fire Protection Association, Batterymarch Park, Quincy, MA 02269.

1-5. EMF Information

Considerations About Welding And The Effects Of Low Frequency Electric And Magnetic Fields

Welding current, as it flows through welding cables, will cause electromagnetic fields. There has been and still is some concern about such fields. However, after examining more than 500 studies spanning 17 years of research, a special blue ribbon committee of the National Research Council concluded that: "The body of evidence, in the committee's judgment, has not demonstrated that exposure to power-frequency electric and magnetic fields is a human-health hazard." However, studies are still going forth and evidence continues to be examined. Until the final conclusions of the research are reached, you may wish to minimize your exposure to electromagnetic fields when welding or cutting.

To reduce magnetic fields in the workplace, use the following procedures:

1. Keep cables close together by twisting or taping them.
2. Arrange cables to one side and away from the operator.
3. Do not coil or drape cables around your body.
4. Keep welding power source and cables as far away from operator as practical.
5. Connect work clamp to workpiece as close to the weld as possible.

About Pacemakers:

Pacemaker wearers consult your doctor first. If cleared by your doctor, then following the above procedures is recommended.

1.0 INTRODUCTION

Your new stud welding equipment is constructed of the finest components and material available. Used properly, this equipment will give you years of profitable, efficient service.

The system incorporates the latest in engineering advances, for complete reliable welding of mild steel, stainless steel, and aluminum.

2.0 WARRANTY

The electrical and mechanical components of the stud welder are thoroughly performance inspected prior to assembly in the welder. The assembled welder is completely performance checked. The welder is delivered to you in functional electro-mechanical condition.

All parts used in the assembly of the welder and its accessories are fully warranted for a period of 1 YEAR from the date of delivery. In addition, the welding capacitors are warranted for a period of 1 YEAR from the date of delivery. The printed circuit boards used in all proweld equipment are warranted for a period of 3 years.

Under the warranty, the manufacturer reserves the right to repair or replace, at their option, defective parts which fail during the guarantee period. Notice of any claim for warranty repair or replacement must be furnished to the manufacturer by the purchaser within ten (10) days after the defect is first discovered. The manufacturer does not assume any liability for paying shipping cost or any labor or materials furnished where such cost are not expressly authorized in writing.

The manufacturer does not warrant any parts or accessories against failures resulting from misuse, abuse, improper installation, maladjustment, or use not in accordance with the operating instructions furnished by the manufacturer. The warranty is valid only when studs are purchased from sources approved by the manufacturer or are of identical specifications to the manufacturer's

3.0 SUGGESTED SAFETY PRECAUTIONS

In any welding operation, it is the responsibility of the welder to observe all safety rules to insure his or her personal safety and to protect those working in the area.

Reference is directed, without endorsement or recommendation, to ANSI Z49.1, Safety in Welding and Cutting, and to AWG Publication A6-66, Recommended Safe Practices for Gas-Shielded Arc Welding.

1. Always treat electricity with respect. Under open circuit conditions, the welding machines output voltage may be dangerous.
2. Don't work on live circuits or conductors. Disconnect the main power before checking the machine or performing any maintenance.
3. Be sure the welding machine cabinet is properly grounded to a good electrical ground. Consult local electrical codes.
4. Never operate a welder in the rain, or operate a welder while standing in water. Avoid wearing wet or sweaty clothes when welding.
5. Don't operate with worn or poorly connected cables, and don't operate the weld gun with loose cable connections. Inspect all cables frequently for insulation failures, exposed wires, loose connections and repair as needed.
6. Don't overload welding cables or continue to operate with over heated cables.
7. Don't weld near flammable materials or liquids in or near the area, or on ducts or pipes carrying explosive gases.

8. Don't weld on containers which have held combustible or flammable materials, or on materials which give off flammable or toxic vapors when heated.
9. Be sure to provide for proper ventilation when welding in a confined area.
10. Never look at the electric arc without wearing protective eye shields.
11. Always use the proper protective clothing, gloves, etc.
12. Never strike an arc when near a bystander who is unaware of the danger of ultraviolet light to their eyes.

4.0 GENERAL DESCRIPTION

AG-800 L.D. ARC GUN
(Part No. 300-0800)
AG-801 L.D. ARC GUN W/DAMPENER
(Part No. 300-0801)

A shaped to the hand, semi automatic stud welding tool. Welds any length stud with a diameter range of 12 gauge through 5/8 inches. Refer to figure 4-1 for weight and size specifications.

5.0 UNPACKING

There is very little to do when unpacking your ARC Stud Welding gun. Your Stud Welder comes complete with all the accessories and tool required for set-up, adjustment, and maintenance. Aside from the correct chuck, ferrule grip, and any special accessories required for your application your ARC weld gun is ready for hook-up to a Pro Weld power source.

Weight (includes standard legs, foot, and 4/0 cables)..... 6.2 pounds

Typical working weight gun plus 4 feet of unsupported 4/0 cables ..7 pounds

Shipping weight of gun plus approximately 8 feet of 4/0 cable and connectors..... 11 pounds

Note: Chuck and ferrule grip are not standard and must be ordered separately.

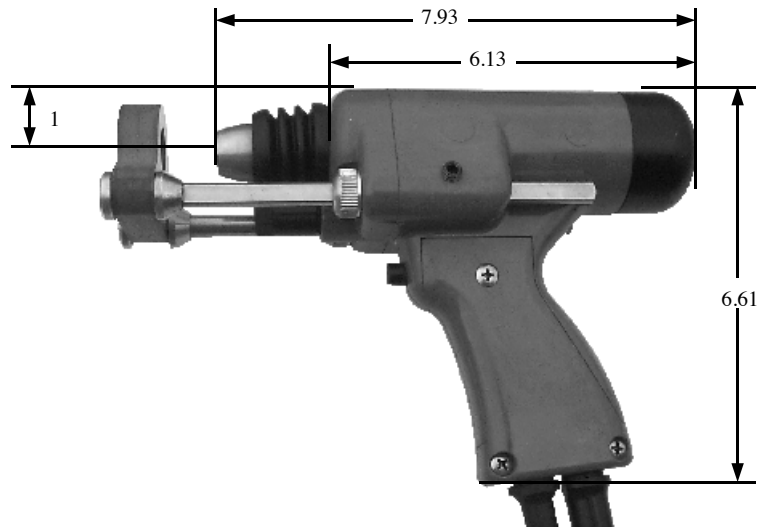

Figure 4-1 Standard AG-800 L.D. ARC Gun

6.0 GUN SET-UP

The standard gun set-up is used for welding the majority of applications. It consists of the standard adjustable face plate, two legs, a foot, chuck adapter, chuck, and spring for your specific stud size.

The following is a step by step explanation of the correct way to set up the gun. (Refer to Figure 6-1)

1. A different, and correctly sized, chuck and ferrule grip are needed for each different stud diameter and style that will be welded. The appropriate chuck, or stud holder, is inserted into the tapered chuck adapter and tapped lightly to insure a tight fit. The ferrule grip is inserted in the hole in the foot and secured with the locking screws to hold it in place.

2. Studs must NOT bind or hang up on the foot, ferrule grip, or ferrule during the entire stud welding process. To assure this, the foot/ferrule arrangement must be centered in relation to the stud to be welded. To assure centering, loosen the locking screws that hold the foot to the legs. Place a stud in the chuck and a ferrule in the grip. With the locking screw

loosened, the foot will move freely in all directions. Adjust the foot so that the stud is centered in the ferrule and no contact occurs between the stud and the ferrule during retraction or forward plunge of the stud. Tighten the locking screws after centering the stud.

3. The “Plunge Length” is the amount of stud exposed beyond the ferrule during initial set-up. Set the plunge by loosening the leg adjusting screws and moving the foot until the stud extends 1/8” to 3/16” past the end of the ferrule. Tighten the leg adjusting screws after setting the plunge and re-check centering to be sure the stud is aligned properly in the ferrule.

4. The lift height, which determines the arc length, has been pre-set at the factory and will automatically lift and plunge the stud during the welding process. “Lift” is the distance the gun will raise the stud above the welding surface during the weld. This distance governs the voltage and the arc. Improper lift will cause unsatisfactory welds.

To measure the lift, turn the stud welding unit on and set the timer to maximum time. (On certain units there may be a Lift Check switch available, and in these cases this switch can be used to check lift.) Trigger the gun in the air or on a non-grounded or insulated surface, to observe the lift cycle. Measuring the distance the stud or gun mechanism moves equals lift. Usually this can be easily done by visual observation or simple measurement against a static reference point (i.e. the ferrule properly seated in the ferrule grip).

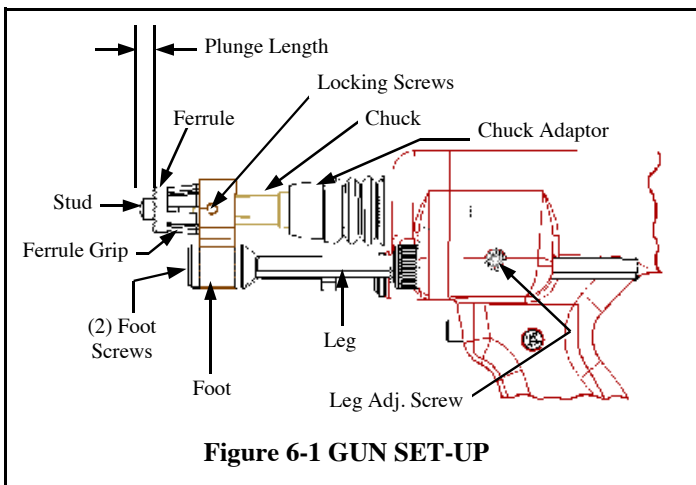

When it does become necessary to adjust the lift, you do so by removing the rear cap from the gun. This will expose the rear coil choke assembly, the set screw, and the lift adjusting screw (Refer to Figure 6-2).

RECOMMENDED LIFT SETTINGS

Stud Base Dia.	Lift Setting
Less than 1/2"	1/16"
1/2" through 3/4"	3/32"
Greater than 3/4"	7/64"

Loosen the set screw.

To increase lift: turn the adjusting screw out (counter clockwise).

To decrease lift: turn the lift adjusting screw in (clockwise).

Once the lift has been set, tighten the set screw and replace the rear cap.

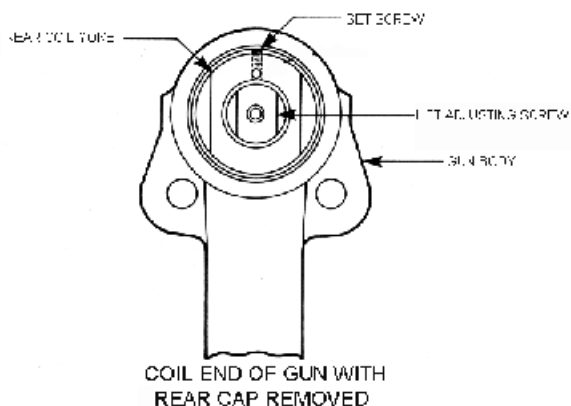

Figure 6-2 LIFT ADJUSTMENT

5. Make sure that the cables are connected to the power source (standard set-up is straight polarity – Negative to controller, or gun, and Positive, ground cable, to work surface).

6. Turn on the power supply and adjust the current and time for the weld base diameter of the fastener to be welded.

7. Place the gun, loaded with the stud and ferrule, squarely against the ground work surface. The main spring in the gun will take up the “plunge length” and the ferrule will seat against the base plate.

8. Pull the trigger holding the gun completely still as above. The gun will lift the stud from the base plate and draw an arc. The end of the stud and the adjacent metal of the base plate will be melted by the weld arc. The gun will then plunge the stud into the molten pool, extinguishing the arc, to end the controlled portion of the weld cycle

.DO NOT MOVE THE GUN DURING THE WELD CYCLE.

9. After the controlled weld cycle, allow the molten metal to solidify briefly with the work surface to assure completion of the cycle (about an extra second holding “still” after the weld is usually sufficient).

10. Remove the gun from the work by lifting straight away from the welded stud (this will assure better life to the gun’s expendable accessories). The ferrule may now be removed by breaking it away from the welded stud to allow inspection of the weld results. After inspection of sample welds the gun can be adjusted, as per the steps in this procedure, for optimum results

7.0 WELD TEST AND INSPECTIONS

Testing of weld quality beyond visual inspection varies with stud characteristics. Refer to AWS (American Welding Society) Structure Welding Code AWS D.1-Rev. 1-76. Welding procedures are covered in Sections 4.28 and 4.29. Weld test and inspection is covered in Section 4.30, paragraphs 1 through 4. (American Welding Society, Inc., 2501 N.W. 7th, Street, Miami, Fla. 33125).

7.1 Weld Test

A. Bend Test

A bend test may be used to test weld results if the stud may be destroyed. This is usually done with a bending tool (a hollow pipe with an inside diameter just large enough to fit over the diameter of the studs). The bend tool is placed over the stud, down to the base material. The stud is then be repeatedly bent away from its axis until failure occurs.

B. Torque Test – Threaded Studs

A torque test may be used on threaded studs. The stud is twisted to the point of failure. A twisting tensile load is applied by using a collar, washer and nut. A bend test can be used on threaded studs as well.

C. Test Results

In an acceptable weld, failure will occur in the stud material or tear out of a thin base plate. Failure in the weld requires adjustment of procedure, weld time and current setting.

7.2 Weld Inspection

Weld quality can be visually inspected. Refer to Figure 7-1 as a reference to the quality of the weld.

7.3 Causes Of Poor Or Erratic Welds

1. Loose chuck. Does not grip stud tightly. (replace) Not enough engagement of stud to chuck. (Adjust stop)
3. Poor surface condition of base material, excessive oil, grease, rust, etc. (Clean)
4. Weld current or weld time setting too low or too high. (Adjust to diameter of studs)
5. Broken or loose cables. (Repair)
6. Dirt in gun. (Clean)
7. Incorrect polarity. (Cables hooked-up wrong)
8. Cables too closely coiled.
9. Arc blow is evidenced by “one side” welds. In severe cases there will be no melting under one edge of flange while the opposite side is gouged out or appears excessively hot. The principle cause of arc blow is a magnetic field induced by the current flow during the weld. It occurs most often on long, narrow strips of metal or near edges of sheets or plates. In some cases, a change in grounding positions, or two ground on the work piece, one at each end or edge of work, will correct the problem

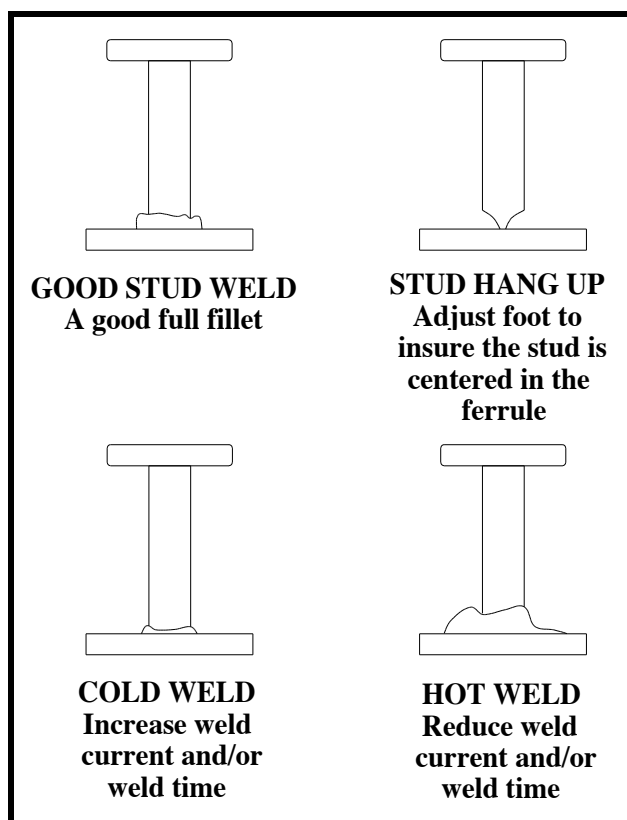

Figure 7-1 WELD INSPECTION

For assistance in sever cases, contact your local sales representative.

10. Incorrect plunge setting. (Adjust to proper setting)

11. Incorrect lift setting. (adjust to proper setting)

12. Poor stud quality.

13. Arc shield so far off center from weld end of stud that stud catches on edge of arc shield and is not driven back into pool of molten metal.

7.4 Trouble Shooting Poor Welds

1. Weld Too Hot

- A) Decrease weld time.
- B) Decrease weld current.
- C) Increase stud protrusion.

2. Weld too Cold

- A) Increase weld time.
- B) Increase weld current.
- C) Decrease stud protrusion

3. Arc Blow

- A) Use double grounds.
- B) Ground too close or not spaced evenly.

4. Hang-Up

- A) Re-align arc shield

8.0 MAINTENANCE

(Refer to LD ARC GUN EXPLODED VIEW in Section 10 of this manual for location for “()” numbers noted in this text.)

8.1 Disassembly of Gun

1. Loosen leg set screws (28), remove foot and leg assembly. Unscrew chuck adaptor and remove bellows (2).

2. Unscrew end cap nuts (3) and remove front cover(4)

3. Disconnect weld cable (31) from lifting rod assm (6) by removing screw (8). Remove lifting rod assembly (6) and main spring (7).

4. Slide out lift stop housing (10), lifting ring (11), moveable core (12), and core spring (13).

5. It is only necessary to remove rear cap (20) for adjusting lift. It is not necessary to remove cap for normal cleaning of gun.

6. To replace damper (33), unscrew plunge damper assembly from front cap (4). The damper will unscrew from the damper cover (32).

8.2 Reassembly of Gun

1. Assemble lifting ring (11) with moveable core (12) and core spring (13) into lift stop housing (10). Install into gun body (14).

2. Install lifting rod assm (6) and main spring (7).

3. Connect weld cable (31) to lifting rod assembly (6) with screw (8).

4. Install front cap (4) end cap nuts (3), bellow (2), and chuck adaptor (1). Make sure chuck adaptor is securely tightened.

5. Guns with plunge damper, replacement damper (33) has to be screwed all the way into the damper cover (32). Screw damper assembly into front cap (4)

6. Install foot and leg assembly. Adjust the plunge and lift.

7. Replace rear cap (20) and secure with screw (21).

8.3 Weld Cable Replacement

1. Disassemble gun as indicated in disassembly of gun through step 4.

2. Remove handle cover screws (26) lift off handle cover (27).

3. Pull weld cable (31) out of gun body (14).

4. Place new weld cable into gun body handle and through cable hole in gun body.

5. Secure weld cable with screw (8) to lifting rod assembly (6). Tighten securely.

6. Install handle cover and reassemble gun.

8.4 Control Cable Replacement

1. Remove handle cover screws (26) lift off handle cover (27).

2. Remove wire nuts from the two wires going to the gun coil (16). Disconnect the two wires from the switch assembly (25) and remove control cable (30).

3. Connect the **black** wire on the new cable (30) to one terminal on the switch assembly (25).

4. Connect the **white** wire to the other terminal.

5. Connect **green** control cable wire to one of the gun coil leads using wire nut.

6. Connect **red** control cable wire to the other gun coil lead using a wire nut.

7. Re-install switch assembly and handle cover.

8.5 Gun Maintenance

If the gun motion becomes sluggish or erratic the gun should be disassembled, cleaned, and lubricated.

A. Disassemble the gun as described. Blow or wipe the gun body and parts clean.

B. The inside diameters of adjustable core screw, the lifting ring and mating diameters on the lifting rod should be carefully examined for wear or rust. Although the lubrication should prevent any oxidation on these surfaces, if they reveal signs of dirt or a dull reddish brown stain, clean and polish with a fine abrasive paper, grip #0 or finer.

C. Lubricate lifting rod surface with a thin coat of high temperature bearing grease, Lubricate M-24-M or equivalent.

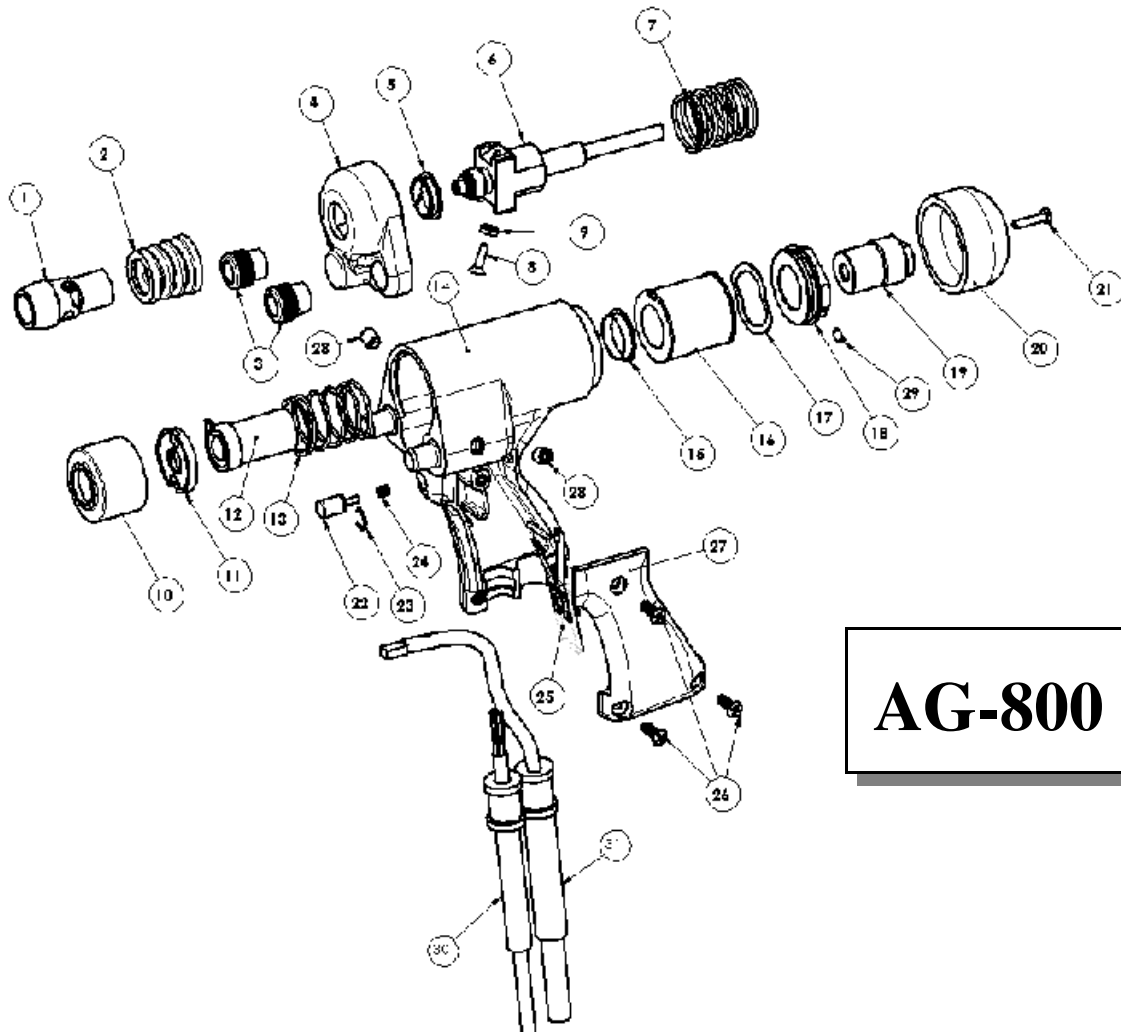

AG-800

ITEM NO.	DESCRIPTION	PART NO.	ITEM NO.	DESCRIPTION	PART NO.
1	CHUCK ADAPTER	302-0026	17	WAVE WASHER	102-0117
2	BELLOW	302-0014	18	YOKE, REAR COIL	301-0016
3	NUT, END CAP	033-481	19	ADJUSTABLE CORE	301-0008
4	FRONT CAP, L.D.	302-0004	20	REAR CAP	033-493
5	BEARING	033-491	21	SCREW, #8-32 X 3/4 PAN HD	037-521
6	LIFTING ROD ASM.	302-0012	22	TRIGGER BUTTON	302-0013
7	SPRING, MAIN	302-0017	23	SNAP RING	302-0023
8	SCREW, #8-32 X 3/8	115-0011	24	SPRING, TRIGGER	302-0016
9	WASHER	302-0025	25	TRIGGER SWITCH ASM	302-0010
10	LIFT STOP HOUSING	301-0019	26	SCREW, #10-32 X 1/2 OVAL	115-0009
11	LIFTING RING	301-0014	27	HANDLE COVER	302-0009
12	MOVEABLE CORE	301-0013	28	SCREW, 5/16-18 X 3/8 SET	037-557
13	SPRING, CORE	301-0012	29	SCREW, #8-32 X 1/4 SET	115-0010
14	GUN BODY	302-0001	30	CONTROL CABLE ASM	302-0028
15	COIL YOKE BEARING	301-0009	31	WELD CABLE ASM	302-0029

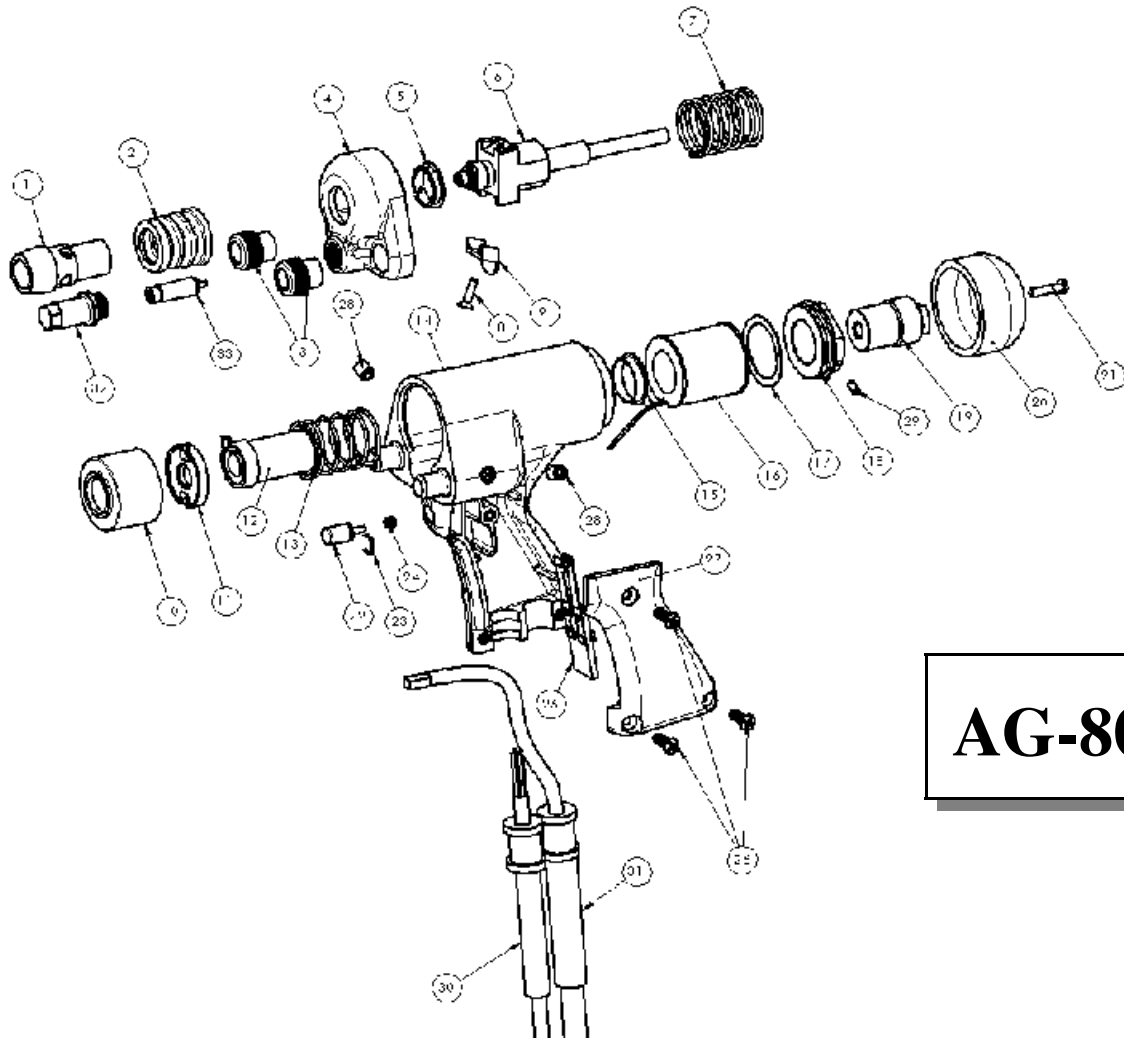

AG-801

ITEM NO.	DESCRIPTION	PART NO.	ITEM NO.	DESCRIPTION	PART NO.
1	CHUCK ADAPTER	302-0026	18	YOKE, REAR COIL	301-0016
2	BELLOW	302-0014	19	ADJUSTABLE CORE	301-0008
3	NUT, END CAP	033-481	20	REAR CAP	033-493
4	FRONT CAP,	302-0003	21	SCREW, #8-32 X 3/4 PAN HD	037-521
5	BEARING	033-491	22	TRIGGER BUTTON	302-0013
6	LIFTING ROD ASM.	302-0012	23	SNAP RING	302-0023
7	SPRING, MAIN	302-0017	24	SPRING, TRIGGER	302-0016
8	SCREW, #8-32 X 3/8	115-0011	25	TRIGGER SWITCH ASM	302-0010
9	DAMPER STOP	302-0021	26	SCREW, #10-32 X 1/2 OVAL	115-0009
10	LIFT STOP HOUSING	301-0019	27	HANDLE COVER	302-0009
11	LIFTING RING	301-0014	28	SCREW, 5/16-18 X 3/8 SET	037-557
12	MOVEABLE CORE	301-0013	29	SCREW, #8-32 X 1/4 SET	115-0010
13	SPRING, CORE	301-0012	30	CONTROL CABLE ASM	302-0028
14	GUN BODY	302-0001	31	WELD CABLE ASM	302-0029
15	COIL YOKE BEARING	301-0009	32	DAMPER COVER	302-0011
16	COIL, GUN	105-0024	33	DAMPER	302-0007
17	WAVE WASHER	102-0117			

Section 9.0

TROUBLE SHOOTING GUIDE

CAUTION:

Turn off the power when trouble shooting the control. Welding voltage can cause electric shock and burns.

Trouble shooting should be done by qualified personnel trained to work on this type of equipment.

PROBLEM	POSSIBLE CAUSE	REMEDY
Control unit cycles but gun does not lift.	Broken or loose control cable wires.	Check all wires for continuity and repair.
	Dirt in gun.	Disassembly and clean.
	Misalignment of accessories i.e. legs, foot piece, grip)	Re-align fastener in center of by loosening the screws holding the foot and the legs.
	Lift incorrectly set.	Adjust lift to recommend settings (See section "Set-up of Weld Gun" for suggested settings.)
Weld quality appears inconsistent from one weld to the next.	Faulty or loose ground connection.	Clean area for grounding. Repair or tighten clamp.
	Poor surface condition, excessive oil, grease, rust etc.	Clean area at each weld.
	Incorrect plunge setting.	Be sure plunge is adequate for fastener being welded. (See section "Set-up of Weld Gun" for suggested settings.)

TROUBLE SHOOTING GUIDE (continued)

CAUTION:

Turn off the power when trouble shooting the control. Welding voltage can cause electric shock and burns.

Trouble shooting should be done by qualified personnel trained to work on this type of equipment.

PROBLEM	POSSIBLE CAUSE	REMEDY
Weld quality (continued)	Poor quality fasteners.	
	Loose chuck	Replace chuck.
Gun lifts but fastener Does not pull away from The work plate.	Loose chuck.	Replace chuck.
	Accessory misalignment.	See previous problem for re-alignment suggestions.

