

GRIPCO®

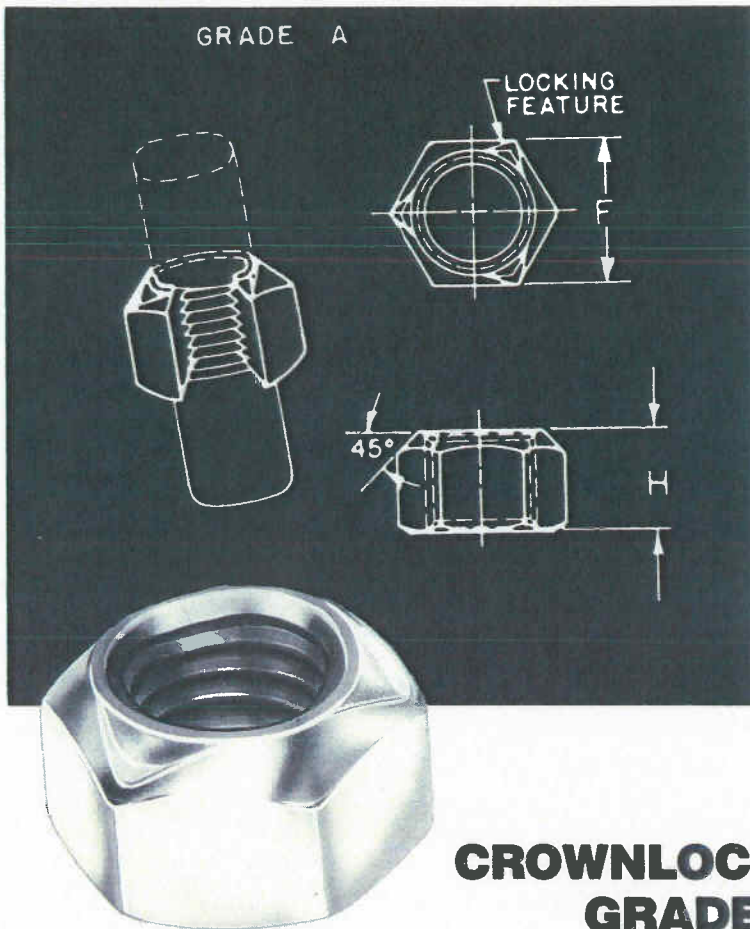

TABLE OF CONTENTS

PREVAILING TORQUE – INCH	SERIES	PAGE
Crownlock Nuts	Grade A	3
Crownlock Nuts	Grade B	4
Crownlock Nuts	Grade C	5
Crownlock Flange Nuts	Grade G	6
Centerlock Nuts	Grade A-B	7
Toplock Nuts	Jam & Machine Screw Series	8
Toplock Flange Nuts	Grade A	9
PREVAILING TORQUE – METRIC		
Metric Crownlock Nuts	Class 9	10
Metric Crownlock Nuts	Class 10	11
Metric Crownlock Flange Nuts	Class 9	12
Metric Crownlock Flange Nuts	Class 10	13
PREPOSITIONED – INCH		
Pilot Projection Weld Nuts	Standard Series	14
Pilot Projection Weld Nuts	Grade B	15
Clinch Nuts	Standard Series	16
Countersunk Weld Nuts	Standard Series	17
Tab Weld Nuts Pilot Projection	P1Series	18
Tab Weld Nuts Pilot Projection	P2 Series	19
Tab Weld Nuts Pilot Projection	S1Series	20
Tab Weld Nuts Pilot Projection	S2 Series	21
PREPOSITIONED METRIC		
Metric Pilot Projection Weld Nuts	Class 9 – Standard Series	22
Metric Pilot Projection Weld Nuts	Class 9 – Counterbore	23
Metric Clinch Nuts	Class 9 Series	24
Metric Tab Weld Nuts Pilot Projection	P1M Series	25
Metric Tab Weld Nuts Pilot Projection	P2M Series	27
Metric Tab Weld Nuts Pilot Projection	S1M Series	28
SPECIALTY PRODUCTS		
Hot Formed Products		29
Warranty Policy		30



Grade A CROWNLOCK NUTS

The Gripco Grade A Crownlock Nuts are manufactured from low carbon steel to meet Grade 2 performance specifications. These prevailing torque nuts are designed for use with Grade 2 bolts.

- No markings are required for a Grade A prevailing torque nut.
- Parts are furnished with a cadmium and wax finish or as requested.
- Gripco Crownlock Nuts meet or exceed all current I.F.I. specifications.
- Prices and samples are available upon request.

CROWNLOCK NUTS GRADE A

SIZE	COARSE PART NO.	SIZE	FINE PART NO.	(F) WIDTH ACROSS FLATS		(H) THICKNESS		CARTON QTY.	WEIGHT PER M
				MAX.	MIN.	MAX.	MIN.		
1/4-20	TLA-1420-S-GRA	1/4-28	TLA-1428-S-GRA	.438	.428	.226	.212	9,000	6.7
5/16-18	TLA-5618-S-GRA	5/16-24	TLA-5624-S-GRA	.500	.489	.273	.258	6,000	10.0
3/8-16	TLA-3816-S-GRA	3/8-24	TLA-3824-S-GRA	.562	.551	.337	.320	4,000	14.7
7/16-14	TLA-7614-S-GRA	7/16-20	TLA-7620-S-GRA	.688	.675	.385	.365	2,000	26.3
1/2-13	TLA-1213-S-GRA	1/2-20	TLA-1220-S-GRA	.750	.736	.448	.427	1,500	34.7
5/8-11	TLA-5811-S-GRA	5/8-18	TLA-5818-S-GRA	.938	.922	.559	.535	800	66.0
3/4-10	TLA-3410-S-GRA	3/4-16	TLA-3416-S-GRA	1.125	1.088	.665	.617	500	115.0
7/8-9	TLA-7809-S-GRA	7/8-14	TLA-7814-S-GRA	1.312	1.269	.776	.724	300	178.0
1"-8	TLA-10008-S-GRA	1"-14	TLA-10014-S-GRA	1.500	1.450	.887	.831	200	268.0
1 1/8-7	TLA-11807-S-GRA	1 1/8-12	TLA-11812-S-GRA	1.688	1.631	.999	.939	120	386.0
1 1/4-7	TLA-11407-S-GRA	1 1/4-12	TLA-11412-S-GRA	1.875	1.812	1.094	1.031	90	500.0
1 1/2-6	TLA-11206-S-GRA	1 1/2-12	TLA-11212-S-GRA	2.250	2.175	1.317	1.245	50	863.0

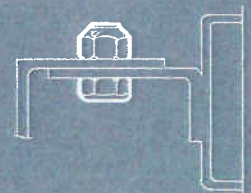
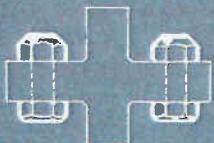

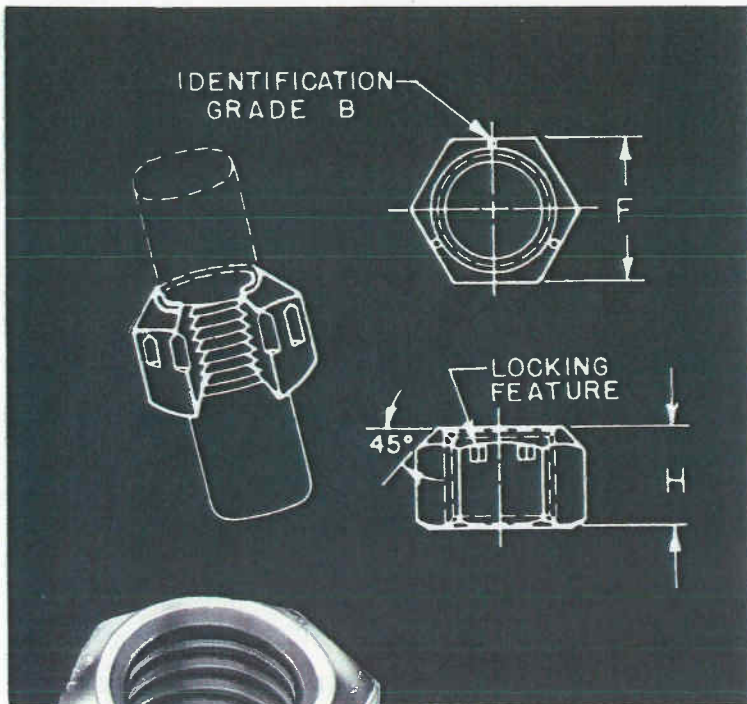

Grade B

CROWNLOCK NUTS

The Gripco Grade B Crownlock Nuts are manufactured from low carbon steel and processed to meet Grade 5 performance specifications. These prevailing torque nuts are designed for use with Grade 5 bolts.

- Three dots at 120° intervals on the crown of the nut identify this product as a Grade B prevailing torque nut.
- Parts are furnished with a cadmium and wax finish or as requested.
- Gripco Crownlock Nuts meet or exceed all current I.F.I. specifications.
- Prices and samples are available upon request.



CROWNLOCK NUTS GRADE B

SIZE	COARSE PART NO.	SIZE	FINE PART NO.	(F) WIDTH ACROSS FLATS		(H) THICKNESS		CARTON QTY.	WEIGHT PER M
				MAX.	MIN.	MAX.	MIN.		
8-32	**TLA-0832-S-GRB			.344	.332	.195	.179	19,000	3.4
10-24	**TLA-1024-S-GRB	10-32	**TLA-1032-S-GRB	.375	.362	.211	.195	15,00	4.3
1/4-20	WLA-1420-S-GRB	1/4-28	WLA-1428-S-GRB	.438	.428	.257	.243	8,500	7.8
5/16-18	WLA-5618-S-GRB	5/16-24	WLA-5624-S-GRB	.500	.489	.302	.292	5,500	11.2
3/8-16	WLA-3816-S-GRB	3/8-24	WLA-3824-S-GRB	.562	.551	.377	.360	3,500	16.0
7/16-14	WLA-7614-S-GRB	7/16-20	WLA-7620-S-GRB	.688	.675	.430	.410	2,000	29.8
1/2-13	WLA-1213-S-GRB	1/2-20	WLA-1220-S-GRB	.750	.736	.510	.490	1,500	39.4
5/8-11	WLA-5811-S-GRB	5/8-18	WLA-5818-S-GRB	.938	.922	.645	.621	700	78.9
3/4-10	WLA-3410-S-GRB	3/4-16	WLA-3416-S-GRB	1.125	1.088	.750	.702	450	126.0

NOTE: 7/8-NC & NF and 1" NC & NF Available

**These sizes will have same type locking feature as Crownlock Nuts A and C.

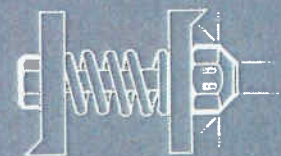
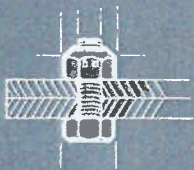

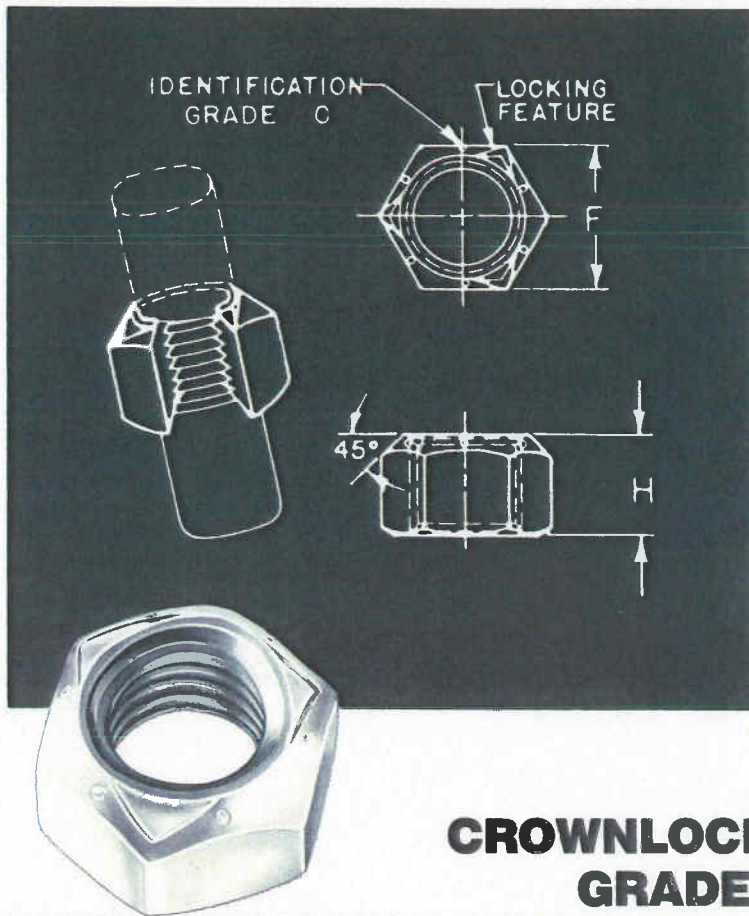

Grade C

CROWNLOCK NUTS

The Gripco Grade C Crownlock Nuts are manufactured from medium carbon steel and heat treated to meet Grade 8 performance specifications. These prevailing torque nuts are designed for high strength applications for use with Grade 8 bolts.

- Six dots at 60° intervals on the crown of the nut identify this product as a Grade C prevailing torque nut.
- Parts are furnished with a cadmium and wax finish or as requested.
- Gripco Crownlock Nuts meet or exceed all current I.F.I. specifications.
- Prices and samples are available upon request.

CROWNLOCK NUTS GRADE C

SIZE	COARSE PART NO.	SIZE	FINE PART NO.	(F) WIDTH ACROSS FLATS		(H) THICKNESS		CARTON QTY.	WEIGHT PER M
				MAX.	MIN.	MAX.	MIN.		
1/4-20	TLA-1420-S-GRC	1/4-28	TLA-1428-S-GRC	.438	.428	.226	.212	9,000	6.7
5/16-18	TLA-5618-S-GRC	5/16-24	TLA-5624-S-GRC	.500	.489	.273	.258	6,000	10.0
3/8-16	TLA-3816-S-GRC	3/8-24	TLA-3824-S-GRC	.562	.551	.337	.320	4,000	14.7
7/16-14	TLA-7614-S-GRC	7/16-20	TLA-7620-S-GRC	.688	.675	.385	.365	2,000	26.3
1/2-13	TLA-1213-S-GRC	1/2-20	TLA-1220-S-GRC	.750	.736	.448	.427	1,500	34.7
9/16-12	TLA-9612-S-GRC	9/16-18	TLA-9618-S-GRC	.875	.861	.496	.473	1,000	53.7
5/8-11	TLA-5811-S-GRC	5/8-18	TLA-5818-S-GRC	.938	.922	.559	.535	800	66.0
3/4-10	TLA-3410-S-GRC	3/4-16	TLA-3416-S-GRC	1.125	1.088	.665	.617	500	115.0
7/8-9	TLA-7809-S-GRC	7/8-14	TLA-7814-S-GRC	1.312	1.269	.776	.724	300	178.0
1"-8	TLA-10008-S-GRC	1"-14	TLA-10014-S-GRC	1.500	1.450	.887	.831	200	268.0
1 1/8-7	TLA-11807-S-GRC	1 1/8-12	TLA-11812-S-GRC	1.688	1.631	.999	.939	120	377.9
1 1/4-7	TLA-11407-S-GRC	1 1/4-12	TLA-11412-S-GRC	1.875	1.812	1.094	1.030	90	500.0
1 1/2-6	TLA-11206-S-GRC	1 1/2-12	TLA-11212-S-GRC	2.250	2.175	1.317	1.245	50	863.0

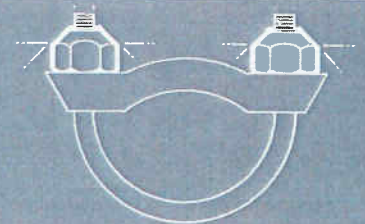
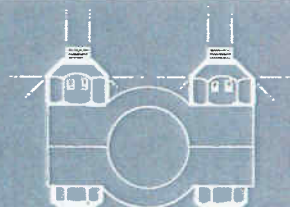
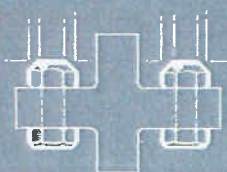

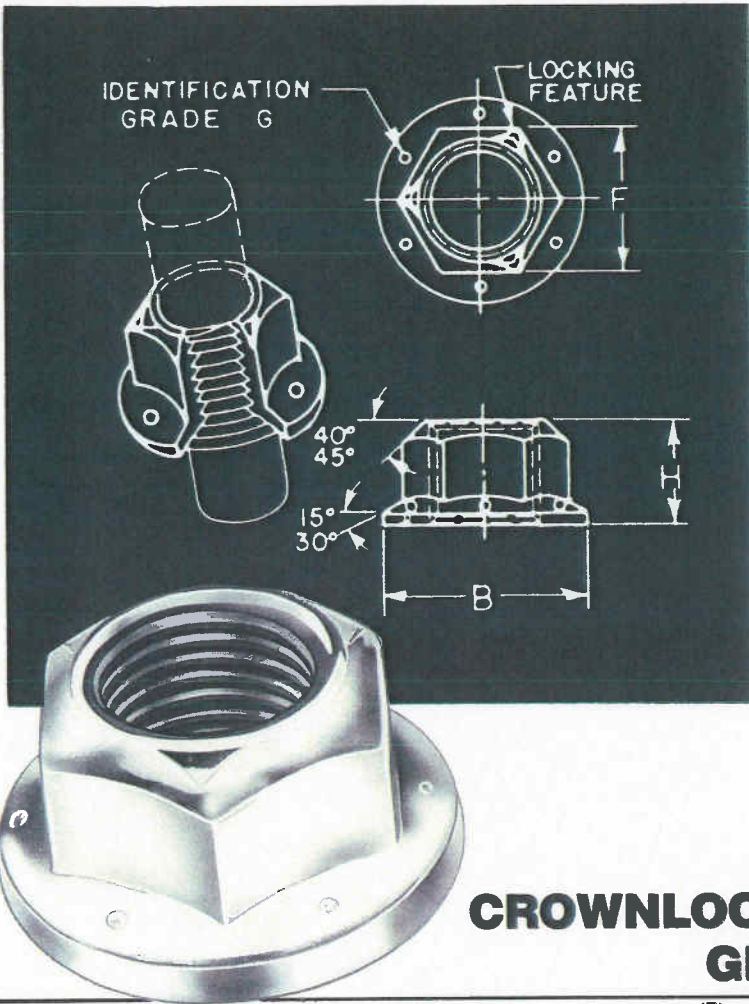

Grade G

CROWNLOCK FLANGE NUTS

The Gripco Grade G Crownlock Flange Nuts are manufactured from medium carbon steel and heat treated to meet Grade G performance specifications. Greater height and the added hoop strength of the flange provide 30% more strength than a standard nut. These prevailing torque nuts are designed for high strength applications for use with Grade 8 bolts.

Six dots at 60° intervals on the top of the flange identify this product as a Grade G prevailing torque flange nut.

- Parts are furnished with a cadmium and wax finish or as requested.
- Gripco Crownlock Flange Nuts meet or exceed all current I.F.I. specifications.
- Prices and samples are available upon request.

CROWNLOCK FLANGE NUTS GRADE G

SIZE	COARSE PART NO.	SIZE	FINE PART NO.	(F) WIDTH ACROSS FLATS		(H) THICKNESS		(B) FLANGE DIAMETER		CARTON QTY.	WEIGHT PER M
				MAX.	MIN.	MAX.	MIN.	MAX.	MIN.		
1/4-20	TLGF-1420-S	1/4-28	TLGF-1428-S	.4385	.428	.291	.251	.560	.522	6,000	9.6
5/16-18	TLGF-5618-S	5/16-24	TLGF-5624-S	.502	.489	.354	.303	.680	.642	4,400	14.8
3/8-16	TLGF-3816-S	3/8-24	TLGF-3824-S	.5645	.551	.421	.357	.810	.770	2,000	25.0
7/16-14	TLGF-7614-S	7/16-20	TLGF-7620-S	.6895	.675	.482	.414	.930	.888	1,500	38.7
1/2-13	TLGF-1213-S	1/2-20	TLGF-1220-S	.752	.736	.550	.469	1.070	1.026	1,000	54.7
9/16-12	TLGF-9612-S	9/16-18	TLGF-9618-S	.877	.861	.611	.527	1.190	1.146		
5/8-11	TLGF-5811-S	5/8-18	TLGF-5818-S	.9395	.922	.678	.581	1.330	1.280	500	107.0
3/4-10	TLGF-3410-S	3/4-16	TLGF-3416-S	1.127	1.088	.802	.682	1.585	1.529	325	166.6
7/8-9	TLGF-7809-S	7/8-14	TLGF-7814-S	1.3145	1.269	.928	.794	1.840	1.778	200	270.5
1"-8	TLGF-10008-S	1"-14	TLGF-10014-S	1.502	1.450	1.047	.897	2.106	2.038		

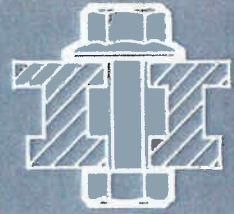
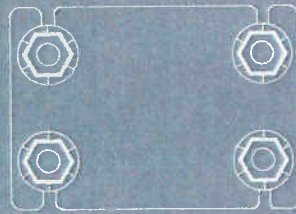
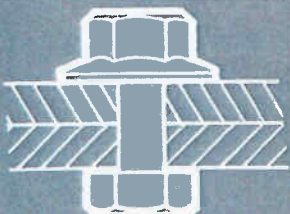

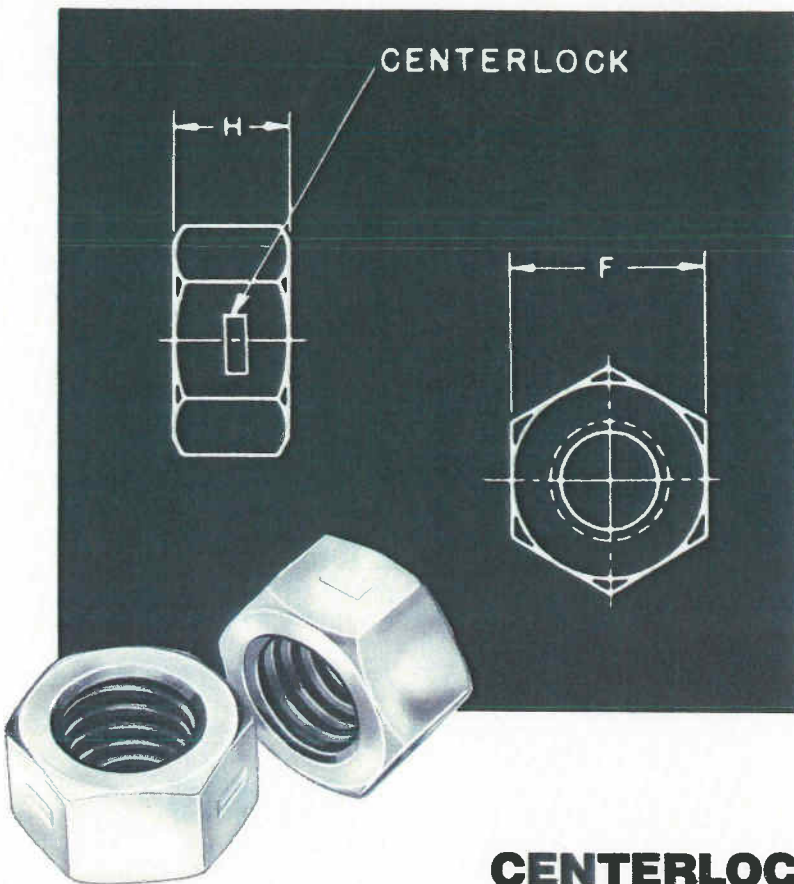

Grade A - Grade B

CENTERLOCK NUTS

The Gripco Grade A Centerlock Nuts are manufactured from low carbon steel to meet Grade A performance specifications. The centerlock design permits thread start from either end of the nut. These prevailing torque nuts are designed for use with Grade 2 bolts.

The Gripco Grade B Centerlock Nuts are manufactured from medium carbon steel and processed to meet Grade B performance specifications. These prevailing torque nuts are designed for use with Grade 5 bolts.

- Parts are furnished with a cadmium and wax finish or as requested.
- Gripco Centerlock Nuts meet or exceed all current I.F.I. specifications.
- Prices and samples are available upon request.

CENTERLOCK NUTS GRADE A — GRADE B

COARSE		FINE		FULL				JAM				JAM			
SIZE	PART NO.	SIZE	PART NO.	(F) WIDTH ACROSS FLATS		(H) GRADE A & B THICKNESS		CARTON QTY.	WEIGHT PER M	(F) WIDTH ACROSS FLATS		(H) THICKNESS		CARTON QTY.	WEIGHT PER M
				MAX.	MIN.	MAX.	MIN.			MAX.	MIN.	MAX.	MIN.		
1/4-20	CLF-1420-S	1/4-28	CLF-1428-S	.438	.428	.226	.212	9,000	7.2						
5/16-18	CLF-5618-S	5/16-24	CLF-5624-S	.500	.489	.273	.258	6,000	10.6						
3/8-16	CLF-3816-S	3/8-24	CLF-3824-S	.563	.551	.337	.320	4,000	15.3	.563	.551	.227	.210	6,000	10.3
7/16-14	CLF-7614-S	7/16-20	CLF-7620-S	.688	.675	.385	.365	2,000	27.8	.688	.675	.260	.240	3,000	18.4
1/2-13	CLF-1213-S	1/2-20	CLF-1220-S	.750	.736	.448	.427	1,500	36.0	.750	.736	.323	.302	2,200	25.6
5/8-11	CLF-5811-S	5/8-18	CLF-5818-S	.938	.922	.559	.535	700	70.8	.938	.922	.387	.363	1,100	48.2
3/4-10	CLF-3410-S	3/4-16	CLF-3416-S	1.125	1.088	.665	.617	500	121.3	1.125	1.088	.446	.398	700	79.0
7/8-9	CLF-7809-S	7/8-14	CLF-7814-S	1.312	1.269	.776	.724	300	194.0					400	122.0
1"-8	CLF-10008-S	1"-14	CLF-10014-S	1.500	1.450	.887	.831	200	294.0					300	197.0

Part Numbers for Grade B Add Suffix GRB

Part Numbers for Jam Add Suffix Jam

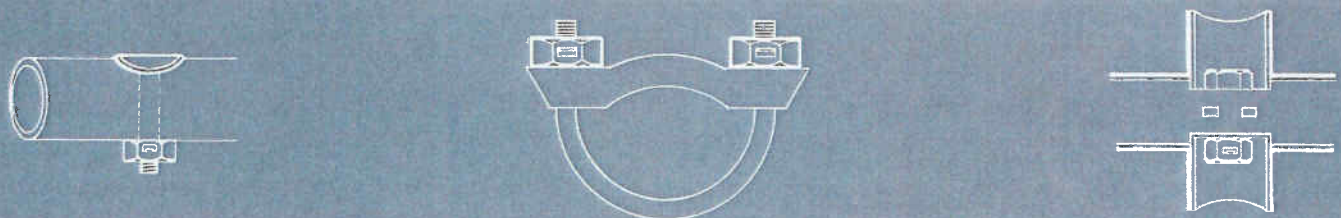

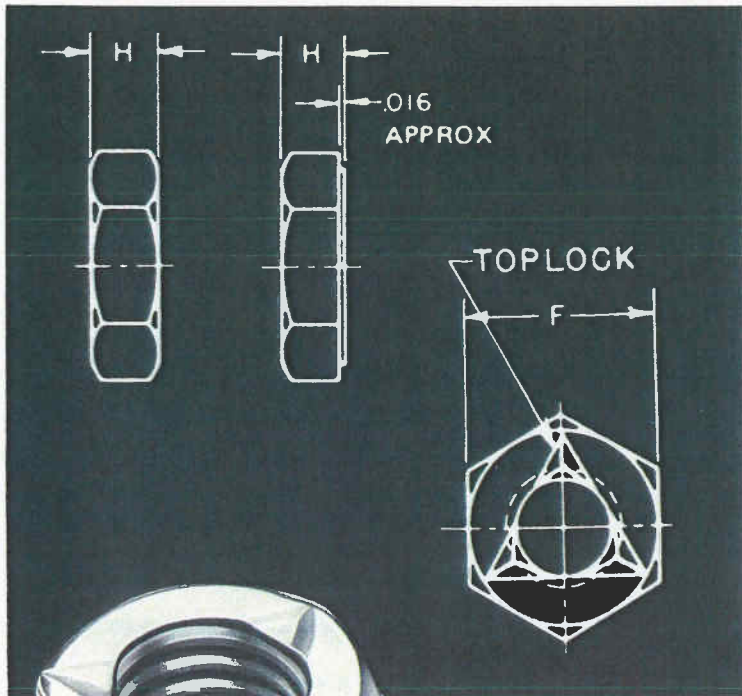

TOPLOCK NUTS

Jam and Machine Screw Series

The Gripco Toplock Nuts are manufactured from low carbon steel to meet Grade A performance specifications. These prevailing torque nuts are designed for use in non-critical applications with Grade 2 bolts.

- Jam and Machine Screw Toplock Nuts are available.
- No markings are required for this series of nuts.
- Parts are furnished with a cadmium and wax finish or as requested.
- Gripco Toplock Nuts meet or exceed all current I.F.I. specifications.

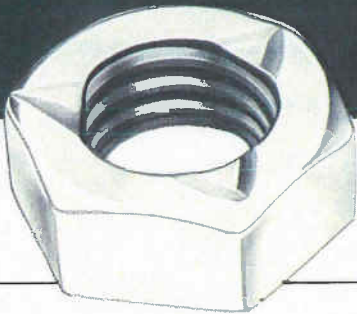

TOPLOCK NUTS JAM AND MACHINE SCREW SERIES

Machine Screw Series

SIZE	COARSE PART NO.	F WIDTH ACROSS FLATS		THICKNESS		CARTON QTY.	WEIGHT PER M
		MAX.	MIN.	MAX.	MIN.		
6-32	TLM-0632-S	.312	.302	.114	.102	30,000	2.0
8-32	TLM-0832-S	.344	.332	.130	.117	23,000	2.8
10-24	TLM-1024-S	.375	.362	.130	.117	20,000	3.3
12-24	TLM-0224-S	.437	.423	.161	.148	11,000	5.6

Finished Hexagon Jam Nut Series

SIZE	COARSE PART NO.	SIZE	FINE PART NO.	F WIDTH ACROSS FLATS		H THICKNESS		CARTON QTY.	WEIGHT PER M
				MAX.	MIN.	MAX.	MIN.		
1/4-20	TLF-1420-S-JAM	1/4-28	TLF-1428-S-JAM	.438	.428	.164	.150	13,000	5.0
5/16-18	TLF-5618-S-JAM	5/16-24	TLF-5624-S-JAM	.500	.489	.195	.180	8,000	7.2
3/8-16	TLF-3816-S-JAM	3/8-24	TLF-3824-S-JAM	.563	.551	.227	.210	6,000	10.3
7/16-14	TLF-7614-S-JAM	7/16-20	TLF-7620-S-JAM	.688	.675	.260	.240	3,000	18.4
1/2-13	TLF-1213-S-JAM	1/2-20	TLF-1220-S-JAM	.750	.736	.323	.302	2,200	25.6
5/8-11	TLF-5811-S-JAM	5/8-18	TLF-5818-S-JAM	.938	.922	.387	.363	1,100	48.2

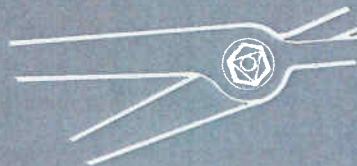

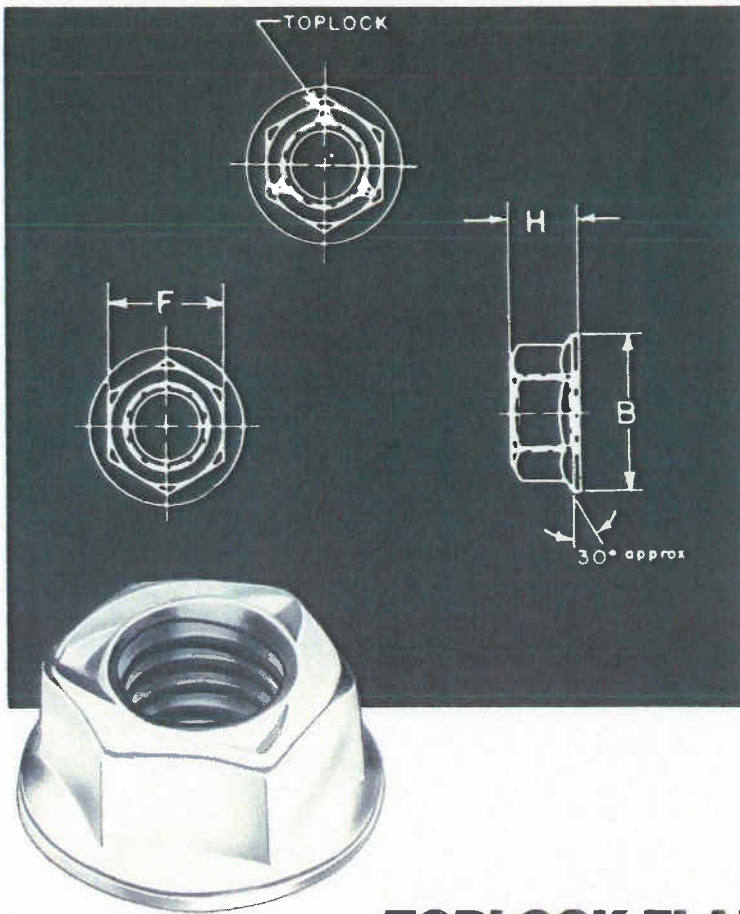

Grade A TOPLOCK FLANGE NUTS

The Gripco Toplock Flange Nuts are manufactured from low carbon steel to meet Grade A performance specifications. These prevailing torque nuts are designed for use with Grade 2 bolts.

- No markings are required for this series of nuts.
- Parts are furnished with a cadmium and wax finish or as requested.
- Gripco Toplock Flange Nuts meet or exceed all current I.F.I. specifications.
- Prices and samples are available upon request.

TOPLOCK FLANGE NUTS GRADE A

SIZE	COARSE PART NO.	SIZE	FINE PART NO.	(F) WIDTH ACROSS FLATS		(H) THICKNESS		(B) FLANGE DIAMETER		CARTON QTY.	WEIGHT PER M
				MAX.	MIN.	MAX.	MIN.	MAX.	MIN.		
8-32	TLNF-0832-S			.344	.334	.203	.187	.469	.452	8,500	5.2
10-24	TLNF-1024-S	10-32	TLNF-1032-S	.375	.365	.219	.203	.500	.480	7,000	6.0
12-24	TLNF-0224-S			.438	.428	.236	.222	.594	.574	4,500	9.9
1/4-20	TLNF-1420-S	1/4-28	TLNF-1428-S	.438	.428	.236	.222	.594	.574	4,500	9.2
5/16-18	TLNF-5618-S	5/16-24	TLNF-5624-S	.500	.489	.283	.268	.680	.660	3,000	13.5
3/8-16	TLNF-3816-S	3/8-24	TLNF-3824-S	.562	.551	.347	.330	.750	.728	2,000	19.1
7/16-14	TLNF-7614-S	7/16-20	TLNF-7620-S	.688	.675	.395	.375	.937	.910	1,200	35.5
1/2-13	TLNF-1213-S	1/2-20	TLNF-1220-S	.750	.736	.458	.437	1.031	1.000	750	47.1

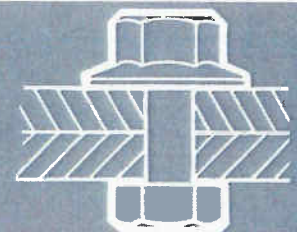
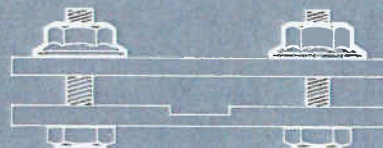

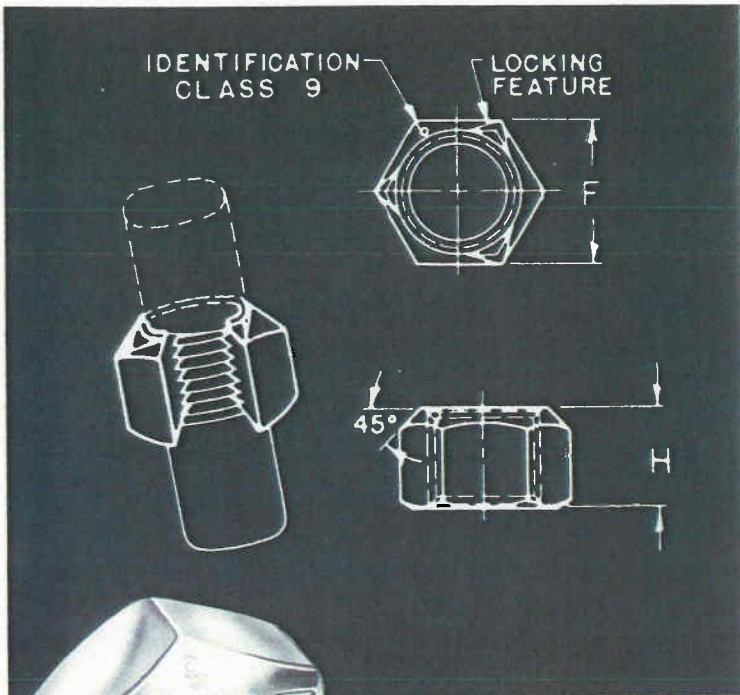

Class 9

METRIC CROWNLOCK NUTS

The Gripco Class 9 Metric Crownlock Nuts are manufactured from low carbon steel to meet Class 9 performance specifications. These prevailing torque nuts are designed for use with Class 9.8 bolts.

- The numeral 9 on the crown of the nut identifies this part as a Class 9 nut.
- Parts are furnished with a cadmium and wax finish or as requested.
- Gripco Metric Crownlock Nuts meet or exceed all current A.N.S.I. specifications.
- Prices and samples are available upon request.



METRIC CROWNLOCK NUTS CLASS 9

PART NO./SIZE	WIDTH ACROSS FLATS		THICKNESS		CARTON QTY.	WEIGHT PER M
	MAX. (F)	MIN.	MAX. (H)	MIN.		
TLA9-M6x1	10.05	9.76	6.7	6.2		
TLA9-M8x1.25	13.05	12.73	8.0	7.4	5,000	11.9
TLA9-M10x1.5	15.05	14.70	11.2	10.2		
TLA9-M12x1.75	18.05	17.67	13.3	12.3	1,500	36.4
TLA9-M14x2	21.05	20.64	15.4	14.3		
TLA9-M16x2	24.05	23.61	17.9	16.8		
TLA9-M20x2.5	30.05	29.00	21.8	20.2		
TLA9-M24x3	36.05	34.80	26.4	24.3		

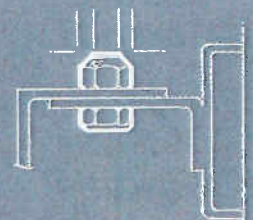
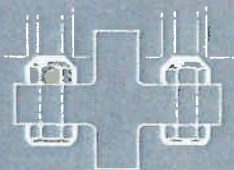

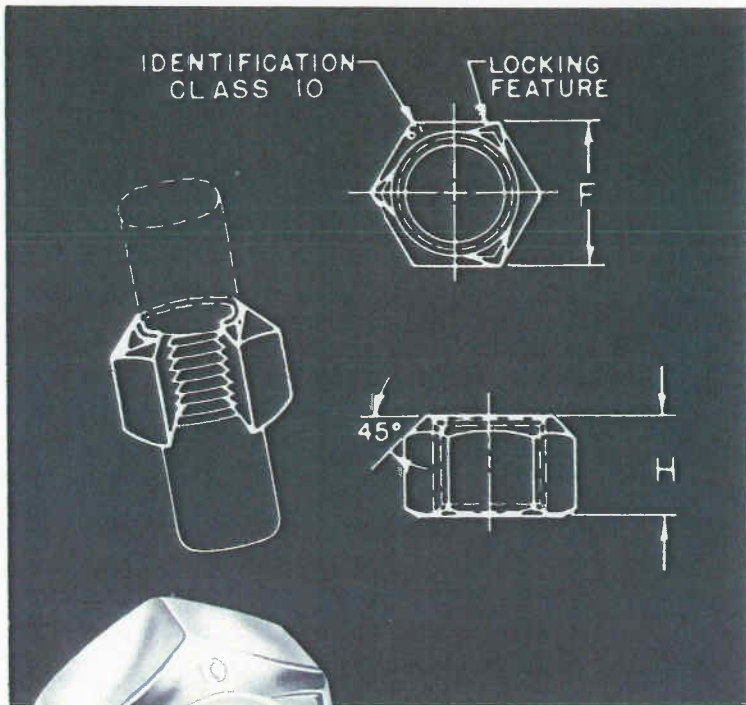

Class 10

METRIC CROWNLOCK NUTS

The Gripco Class 10 Metric Crownlock Nuts are manufactured from medium carbon steel and heat treated to meet Class 10 performance specifications. These prevailing torque nuts are designed for use with Class 10.9 bolts.

- The numeral 10 on the crown of the nut identifies this part as a Class 10 nut.
- Parts are furnished with a cadmium and wax finish or as requested.
- Gripco Metric Crownlock Nuts meet or exceed all current A.N.S.I. specifications.
- Prices and samples are available upon request.

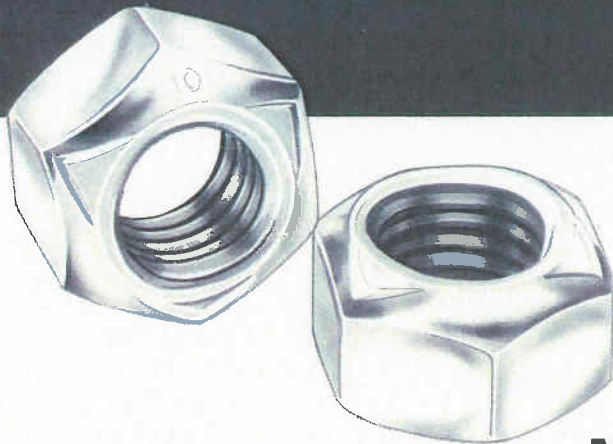

METRIC CROWNLOCK NUTS CLASS 10

PART NO./SIZE	WIDTH ACROSS FLATS			THICKNESS		CARTON QTY.	WEIGHT PER M
	MAX.	(F)	MIN.	MAX. (H)	MIN.		
TLA10-M6x1	10.05		9.76	5.75	5.4	10,000	5.5
TLA10-M8x1.25	13.05		12.73	6.9	6.5	5,500	11.2
TLA10-M10x1.5	15.05		14.70	9.05	8.6	3,000	17.2
TLA10-M12x1.75	18.05		17.67	11.1	10.6	1,800	31.6
TLA10-M14x2	21.05		20.64	12.45	11.9	1,200	47.5
TLA10-M16x2	24.05		23.61	14.5	13.9	850	73.8
TLA10-M20x2.5	30.05		29.00	18.1	17.4	400	136.0

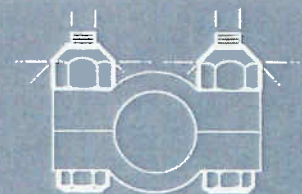
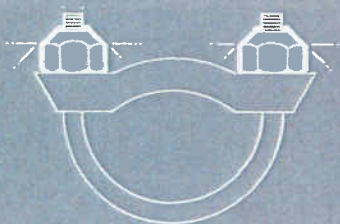
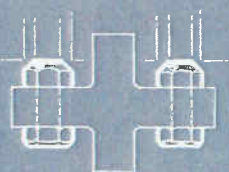

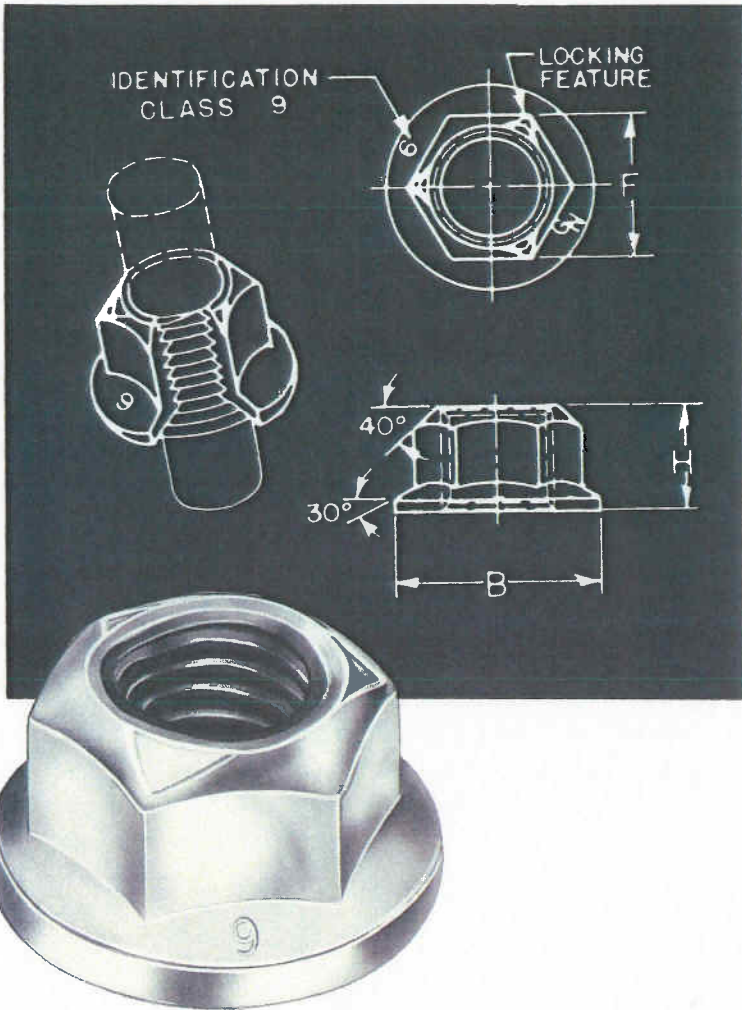

Class 9 METRIC CROWNLOCK FLANGE NUTS

The Gripco Metric Crownlock Flange Nuts are manufactured from low carbon steel to meet Class 9 performance specifications. Greater height and the added hoop strength of the flange provide 30% more strength than a standard nut. These prevailing torque nuts are designed for use with Class 9.8 bolts.

- The numeral 9 on the top of the flange identifies this part as a Class 9 flange nut.
- Parts are furnished with a cadmium and wax finish or as requested.
- Gripco Metric Crownlock Flange Nuts meet or exceed all current A.N.S.I. specifications.
- Prices and samples are available upon request.

METRIC CROWNLOCK FLANGE NUTS CLASS 9

PART NO./SIZE	WIDTH ACROSS FLATS		THICKNESS		FLANGE DIAMETER		CARTON QTY.	WEIGHT PER M
	MAX.	(F) MIN.	MAX.	(H) MIN.	MAX.	(B) MIN.		
TLF9-M6x1	10.00	9.76	7.70	7.35	14.2	13.2	7,000	8.8
TLF9-M8x1.25	13.00	12.73	9.40	9.00	17.6	16.9	3,500	18.0
TLF9-M10x1.5	15.00	14.70	12.25	11.75	21.5	20.8	1,700	30.0
TLF9-M12x1.75	18.00	17.67	13.00	12.4	25.6	24.9		
TLF9-M14x2	21.00	20.64	17.05	16.50	29.6	28.4	650	89.6

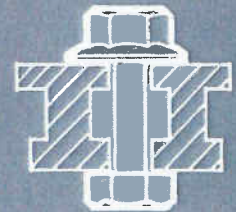
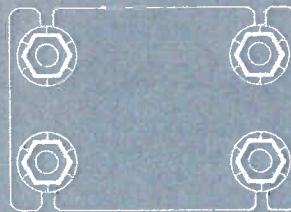

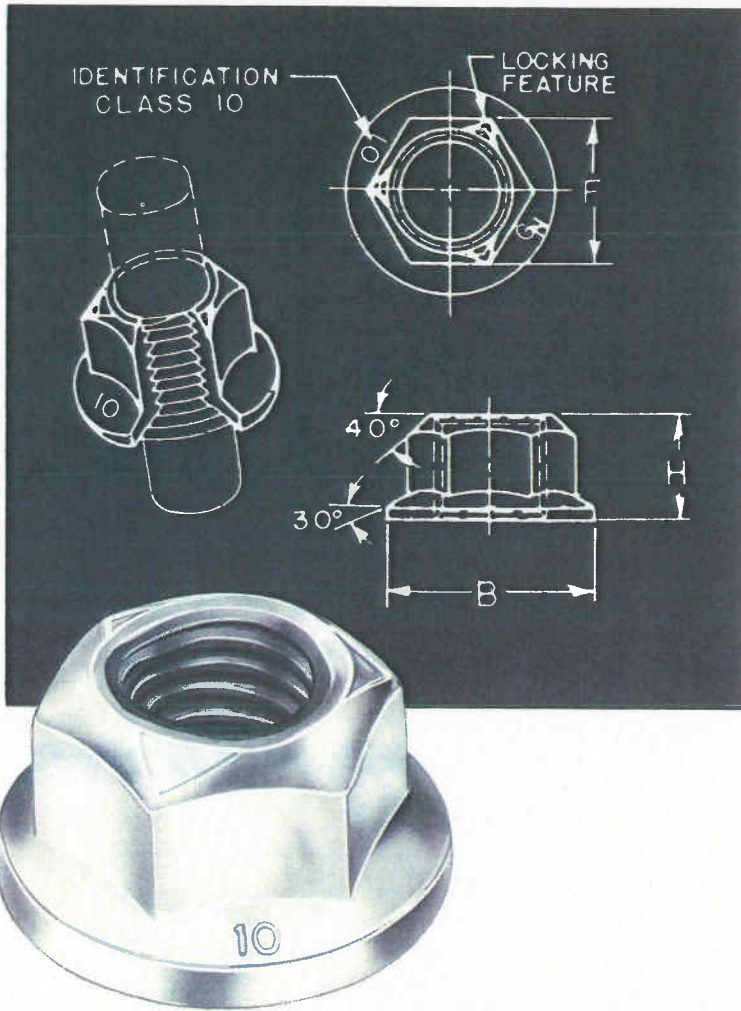

Class 10

METRIC CROWNLOCK FLANGE NUTS

The Gripco Metric Crownlock Flange Nuts are manufactured from medium carbon steel and heat treated to meet Class 10 performance specifications. Greater height and the added hoop strength of the flange provide 30% more strength than a standard nut. These prevailing torque nuts are designed for high strength applications for use with Class 10.9 bolts.

- The numeral 10 on the top of the flange identifies this part as a Class 10 flange nut.
- Parts are furnished with a cadmium and wax finish or as requested.
- Gripco Metric Crownlock Flange Nuts meet or exceed all current A.N.S.I. specifications.
- Prices and samples are available upon request.

CROWNLOCK FLANGE NUTS CLASS 10

PART NO./SIZE	WIDTH ACROSS FLATS			THICKNESS			FLANGE DIAMETER			CARTON QTY.	WEIGHT PER M
	MAX.	(F)	MIN.	MAX.	(H)	MIN.	MAX.	(B)	MIN.		
TLF10-M6x1	10.05		9.76	7.4		6.4	14.2		13.2	8,000	7.7
TLF10-M8x1.25	13.05		12.73	9.1		8.1	17.6		16.8	3,500	16.4
TLF10-M10x1.5	15.05		14.70	11.7		10.7	21.5		20.4	2,000	29.0
TLF10-M12x1.75	18.05		17.67	14.0		12.8	25.6		24.5	1,000	52.7
TLF10-M14x2	21.05		20.64	15.9		14.6	29.6		28.5	650	79.7
TLF10-M16x2	24.05		23.61	18.9		17.6	34.2		32.9	450	122.0
TLF10-M20x2.5	30.05		29.00	23.9		22.4	42.3		40.8	200	213.2

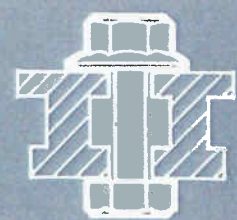
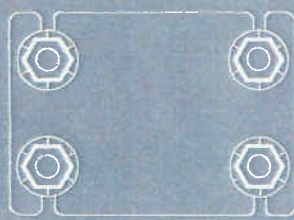
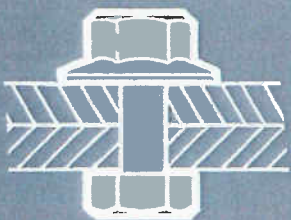

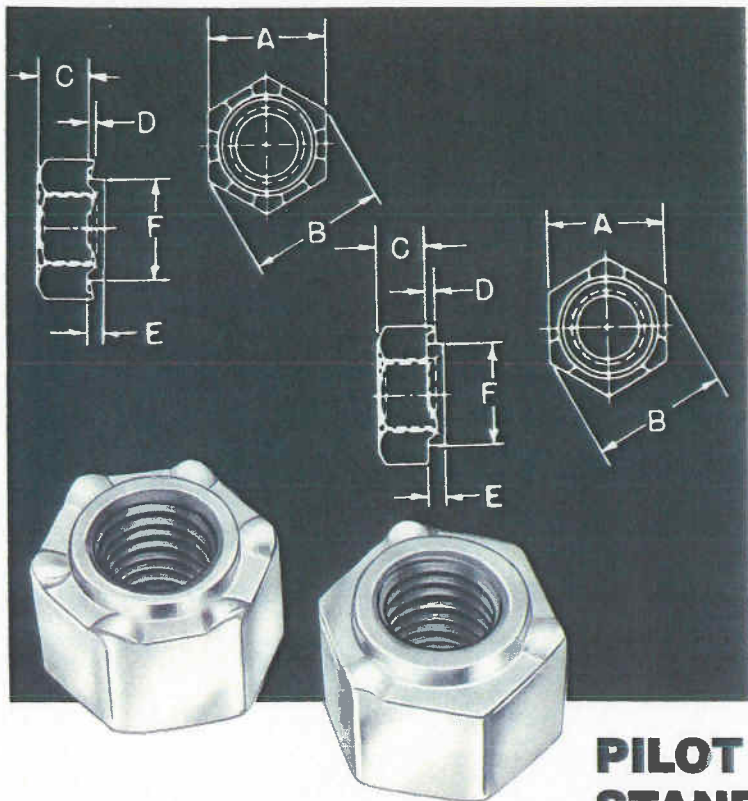

Standard Series

PILOT PROJECTION WELD NUTS

The Gripco Standard Series of Pilot Projection Weld Nuts are manufactured from low carbon steel for use with Grade 2 bolts.

These weld nuts are engineered for positioning in pierced or drilled holes. The pilot eliminates the need for expensive jigs or centering devices and helps reduce welding spatter from entering the nut threads.

The three and six projection types provide a non-rocking, firm current connection during welding. The mass of the projections is increased in proportion to increased pilot heights to assure welds on thick or thin metals.

- No markings are required for Standard Series Pilot Projection Weld Nuts.
- This product is also available with the Gripco prevailing torque feature.
- Prices and samples are available upon request.

PILOT PROJECTION WELD NUTS STANDARD SERIES

	Size	Part Number		A Width Across Flats	B Min. Width Across Corners	C Thick- ness ± .010	D Projection Height ± .003	E Pilot Height ± .005	F Pilot Dia. + .000 - .012	Pilot Hole Dia.	Carton Qty.	Weight Per M
		NC	NF									
Long Pilot	8-32	C-88		.500	.556	.187	.040	.085	.406	.421	6,000	10.3
	10-24&32	C-108	F-108	.500	.556	.187	.040	.085	.406	.421	6,000	11.3
	12-24&28	C-028	F-028	.500	.556	.187	.040	.085	.406	.421	6,000	11.0
	1/4-20&28	C-148	F-148	.500	.556	.187	.040	.085	.406	.421	6,000	10.6
	5/16-18&24	C-5168	F-5168	.562	.624	.218	.040	.085	.469	.484	4,400	13.7
	3/8-16&24	C-388	F-388	.625	.691	.250	.040	.085	.531	.546	3,200	18.9
	7/16-14&20	C-7168	F-7168	.750	.830	.312	.040	.085	.656	.671	1,700	34.0
	1/2-13&20	C-128	F-128	.812	.898	.375	.040	.085	.719	.734	1,300	45.0
	5/8-11&18	C-588	F-588	.937	1.051	.437	.040	.085	.781	.796	800	62.4
For use with 13 gage (.0897") metal or thicker												
Short Pilot	8-32	C-84		.500	.556	.187	.025	.040	.406	.421	6,000	11.0
	10-24&32	C-104	F-104	.500	.556	.187	.025	.040	.406	.421	6,000	11.3
	12-24&28	C-024	F-024	.500	.556	.187	.025	.040	.406	.421	6,000	11.0
	1/4-20&28	C-144	F-144	.500	.556	.187	.025	.040	.406	.421	6,000	9.3
	5/16-18&24	C-5164	F-5164	.562	.624	.218	.025	.040	.469	.484	4,400	13.7
	3/8-16&24	C-385	F-385	.625	.691	.250	.030	.050	.531	.546	3,200	18.9
	7/16-14&20	C-7165	F-7165	.750	.830	.312	.030	.050	.656	.671	1,700	34.0
	1/2-13&20	C-126	F-126	.812	.898	.375	.035	.060	.719	.734	1,300	45.0
	5/8-11&18	C-586	F-586	.937	1.051	.437	.035	.060	.781	.796	800	62.4

For use with 14 gage (.0747") metal or thinner
For 3 projection add suffix (-) for 6 projection add suffix (-6)

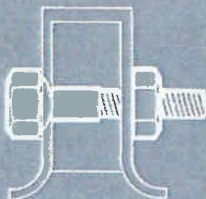

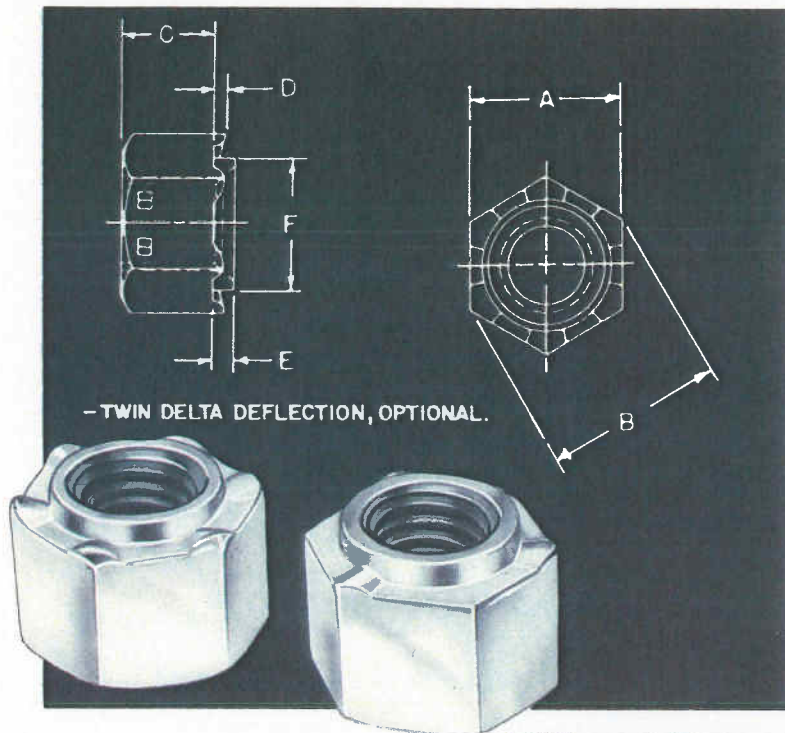

Grade B

PILOT PROJECTION WELD NUTS

The Gripco Grade B Pilot Projection Weld Nuts are manufactured from low carbon steel to meet Grade B performance specifications. These nuts are designed for use with grade 5 bolts.

These weld nuts are engineered for positioning in pierced or drilled holes. The pilot eliminates the need for expensive jigs or centering devices and helps reduce welding spatter from entering the nut threads.

The three and six projection types provide a non-rocking, firm current connection during welding. The mass of the projections is increased in proportion to increased pilot heights to assure weld on thick or thin metals.

- No markings are required for Grade B Pilot Projection Weld Nuts.
- This product is also available with the Gripco prevailing torque feature.
- Prices and samples are available upon request.

PILOT-PROJECTION WELD NUTS GRADE B

Size	LONG PILOT		A Width Across Flats	B Min. Width Across Corners	C Thick- ness	D Projection Height ± .003	E Pilot Height ± .005	F Pilot Dia. + .000 - .012	Pilot Hole Dia.	Carton Qty.	Weight Per M
	NC	Part Number NF									
1/4-20&28	C-148-S-GRB	F-148-S-GRB	.500	.556	.257 .243	.040	.085	.406	.421	5,000	13.6
3/16-18&24	C-5168-S-GRB	F-5168-S-GRB	.562	.624	.302 .292	.040	.085	.469	.484	3,500	18.8
3/8-16&24	C-388-S-GRB	F-388-S-GRB	.625	.691	.370 .360	.040	.085	.531	.546	2,200	27.7
7/16-14&20	C-7168-S-GRB	F-7168-S-GRB	.750	.830	.430 .410	.040	.085	.656	.671	1,400	44.9
1/2-13&20	C-128-S-GRB	F-128-S-GRB	.812	.898	.510 .490	.040	.085	.719	.734	1,000	60.9
Size	SHORT PILOT		A Width Across Flats	B Min. Width Across Corners	C Thick- ness	D Projection Height ± .003	E Pilot Height ± .005	F Pilot Dia. + .000 - .012	Pilot Hole Dia.	Carton Qty.	Weight Per M
	NC	Part Number NF									
1/4-20&28	C-144-S-GRB	F-144-S-GRB	.500	.556	.257 .243	.025	.040	.406	.421	5,000	12.4
3/16-18&24	C-5164-S-GRB	F-5164-S-GRB	.562	.624	.302 .292	.025	.040	.469	.484	3,500	17.1
3/8-16&24	C-385-S-GRB	F-385-S-GRB	.625	.691	.377 .360	.030	.050	.531	.546	2,200	27.7
7/16-14&20	C-7165-S-GRB	F-7165-S-GRB	.750	.830	.430 .410	.030	.050	.656	.671	1,400	44.9
1/2-13&20	C-126-S-GRB	F-126-S-GRB	.812	.898	.510 .490	.035	.060	.719	.734	1,000	59.9

For 3 projection add suffix (-1) for 6 projection add suffix (-6)

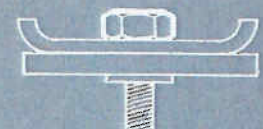
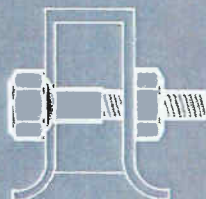

Standard Series

CLINCH NUTS

The Gripco Standard Series Clinch Nuts are manufactured from low carbon steel. These nuts are designed for use with sheet metal or similar materials where extruding and tapping are not advisable or possible. They may be used in open or blind applications.

Gripco Clinch Nuts are designed with a hex pilot to prevent rotation in a hex hole. This product can be staked for floating applications to accommodate bolt misalignment. They also can be clinched solid providing excellent push out strength for rigid applications.

Where flush mounting is required, a button die in combination with a hex punch provides an embossed relief in the stamping. These nuts can be automatically fed and clinched on volume production lines or individually clinched with riveters, orbital riveters, or arbor type presses.

- No markings are required on Clinch Nuts
- This product is also available with the Gripco prevailing torque feature.
- Prices and samples are available upon request.

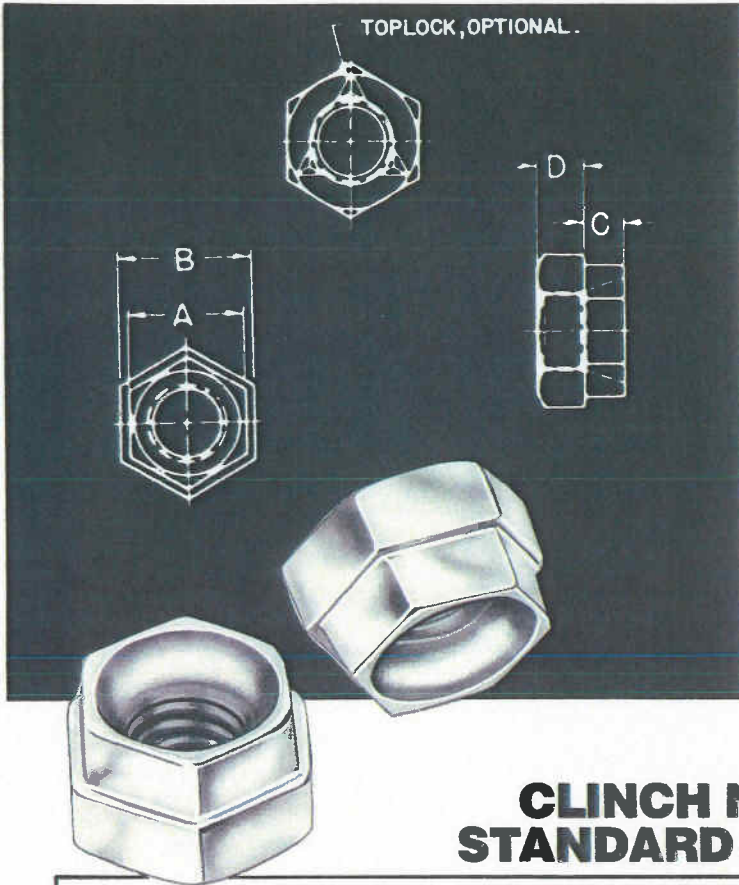

CLINCH NUTS STANDARD SERIES

Size	Part Number		A Pilot Width	B Nut Width	C Pilot Height	D Nut Height	Hexhole In Plate	Carton Quantity	Weight Per M
	NC	NF							
1/4"-20&28	K-1420	K-1428	.429	.521	.125	.171	.437	5,500	11.7
5/16"-18&24	K-5618	K-5624	.491	.584	.156	.203	.500	3,500	17.1
3/8"-16&24	K-3816	K-3824	.551	.670	.187	.234	.562	2,300	25.4
7/16"-14&20	K-7614	K-7620	.614	.742	.218	.265	.625	1,600	34.0
1/2"-13&20	K-1213	K-1220	.742	.866	.250	.296	.750	1,000	55.0
5/8"-11&18	K-5811	K-5818	.922	1.047	.312	.359	.937	550	98.7

CLINCHING FORCE REQUIREMENTS

Size Nut	Approx. Metal Thickness	Approx. Clinching Force For Steel
1/4"	.055	10,000 lbs.
5/16"	.055	12,000 lbs.
3/8"	.055	14,000 lbs.
7/16"	.075	20,000 lbs.
1/2"	.100	24,000 lbs.
5/8"	.132	36,000 lbs.

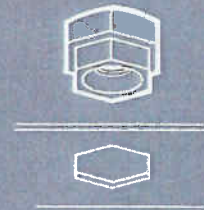
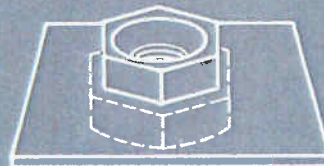
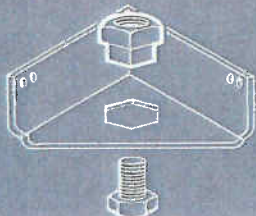

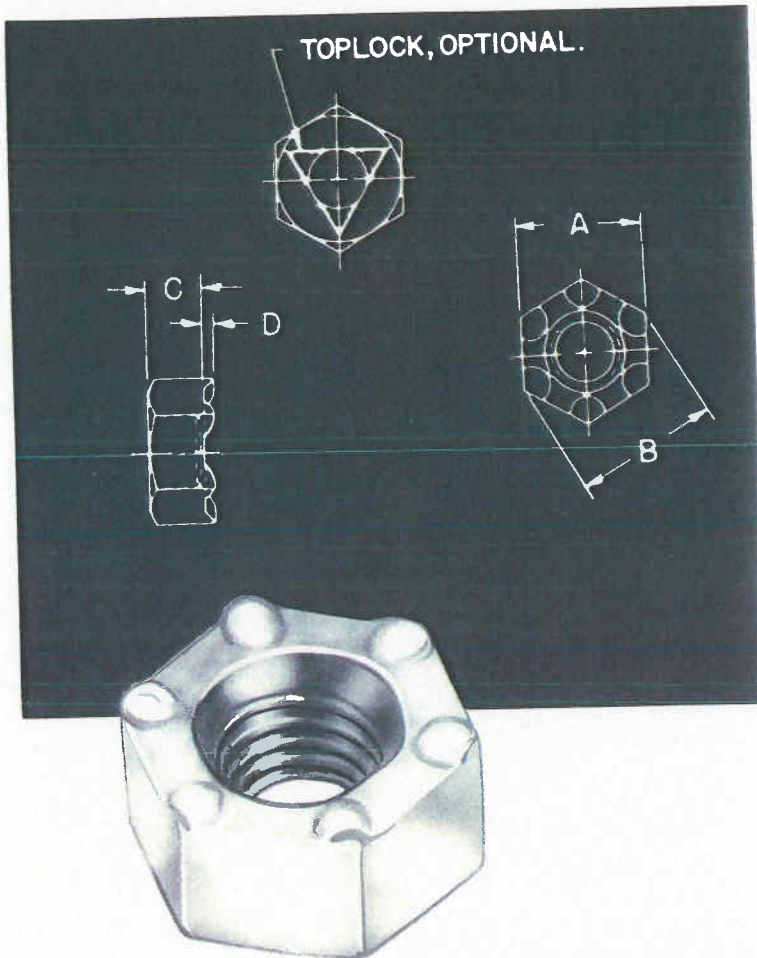

Standard Series

COUNTERSUNK WELD NUTS

The Gripco Standard Series Countersunk Weld Nuts are manufactured from low carbon steel. These nuts are designed to eliminate the time consuming retapping of threads frequently required after welding.

The bearing surface base of the nut is countersunk to prevent fouling of the nut threads by molten metal particles discharged during welding. The Gripco Countersunk Weld Nuts can be welded to a blind surface as well as curved surfaces and over pre-punched or drilled holes.

These Countersunk Weld Nuts can also be utilized as a spacer or weld pad.

- No markings are required on Countersunk Weld Nuts.
- This product is also available with the Gripco prevailing torque feature.
- May be manufactured in quantity to dimensions other than standard.
- Prices and samples are available upon request.

COUNTERSUNK WELD NUTS STANDARD SERIES

Size	Part Number		A Width Across Flats	B Min. Width Across Corners	C Thick- ness	D Projection Height	Carton Qty.	Weight Per M
	NC	NF						
8-32	C-8		.437	.485	.187	.030	9,300	7.2
10-24&32	C-10	F-10	.437	.485	.187	.030	9,300	7.0
1/4-20&28	C-14	F-14	.437	.485	.187	.030	9,300	6.0
5/16-18&24	C-516	F-516	.625	.691	.218	.035	3,200	20.0
3/8-16&24	C-38	F-38	.750	.830	.312	.040	1,900	32.5
1/2-13&20	C-12	F-12	.875	.966	.437	.040	1,000	57.6
5/8-11&18	C-58	F-58	1.062	1.175	.625	.040	520	117.0

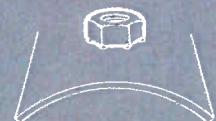
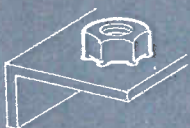

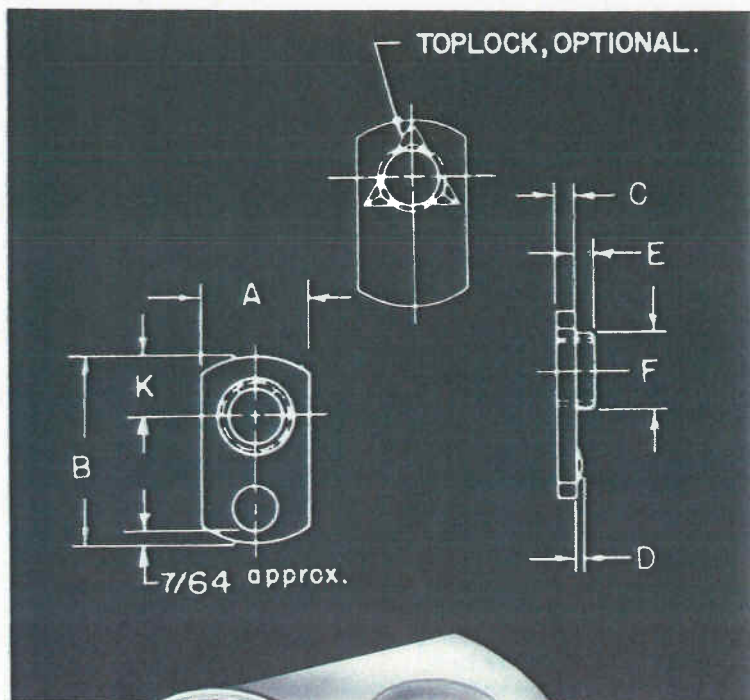

Pilot Projection P1 Series **TAB WELD NUTS**

The Gripco P1 Series, Tab Weld Nuts are manufactured from low carbon steel. These Tab Weld Nuts have been carefully engineered to offer fast, dependable results on flat sections, confined corners, close spacing, flanges and narrow channels in open and blind applications.

The self-locating pilot positions the nut for assembly. The height of the pilot helps prevent welding spatter from entering the nut threads. The nut can be welded to a wide variety of metal thicknesses.

- Prevailing Torque feature can be incorporated on the side opposite the pilot.
- Can be furnished with plating if required.
- Prices and samples are available upon request.

TAB WELD NUTS PILOT PROJECTION-P1 SERIES

Size	Part Number	A Width	B Length	C Thickness	K	Pilot		Pilot Hole Diam.	Projection Height	Carton Qty.	Weight Per M
						E	F				
6-32	P1C-6-S	.437	.625	.094	.187	.031	.187	.203	.020	10,000	6.4
8-32	P1C-8-S	.437	.625	.094	.187	.031	.203	.218	.020	10,000	6.3
10-24	P1C-10-S	.437	.625	.094	.187	.031	.234	.250	.020	10,000	6.1
1/4-20	P1C-14-S	.500	.812	.105	.250	.046	.296	.312	.025	6,000	10.2
5/16-18	P1C-56-S	.625	1.125	.135	.343	.078	.359	.375	.030	2,500	23.1
3/8-16	P1C-38-S	.625	1.125	.135	.343	.093	.437	.453	.030	2,500	20.8

Also Available in Fine Thread Series (NF) in sizes #10 thru 3/8. Dimensions shown are nominal.

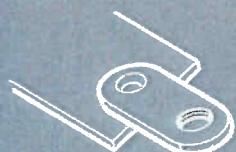

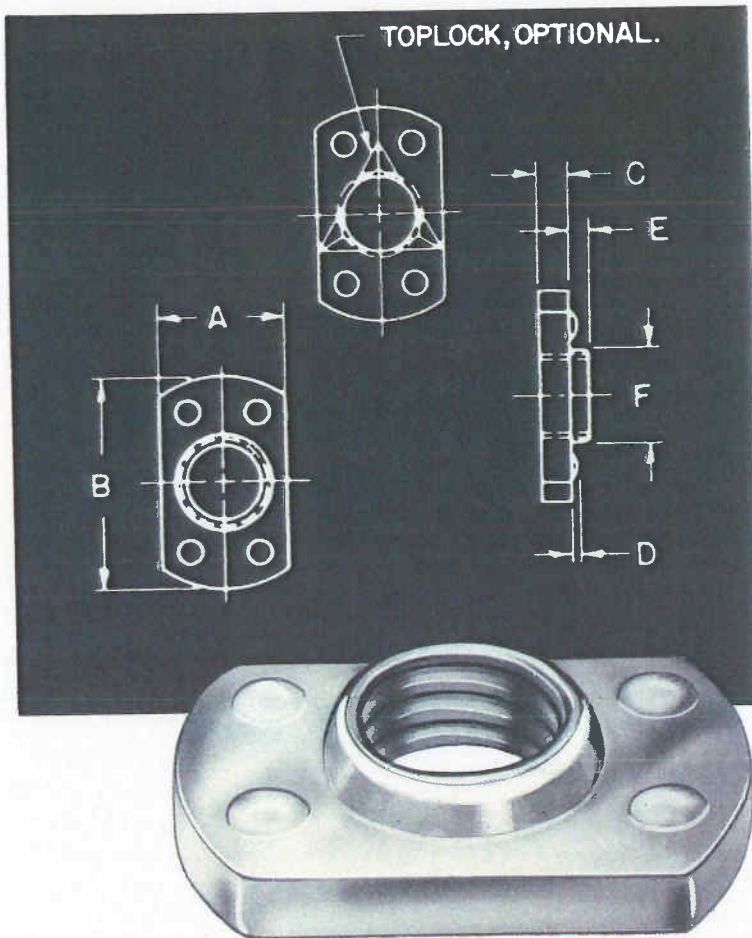

Pilot Projection P2 Series

TAB WELD NUTS

The Gripco P2 Series, Tab Weld Nuts are manufactured from low carbon steel. These Tab Weld Nuts have been carefully engineered to offer fast, dependable results on flat sections, confined corners, close spacing, flanges and narrow channels in open and blind applications.

The self-locating pilot positions the nut for assembly. The height of the pilot helps prevent welding spatter from entering the nut threads. The nut can be welded to a wide variety of metal thicknesses.

- Prevailing Torque feature can be incorporated on the side opposite the pilot.
- Can be furnished with plating if required.
- Prices and samples are available upon request.

TAB WELD NUTS PILOT PROJECTION-P2 SERIES

Size	Part Number	A Width	B Length	C Thickness	Pilot		Pilot Hole Diam.	D Projection Height	Carton Qty.	Weight Per M
					E	F				
6-32	P2C-6-S	.375	.625	.094	.031	.187	.203	.020	12,000	5.5
8-32	P2C-8-S	.375	.625	.094	.031	.203	.218	.020	12,000	5.5
10-24	P2C-10-S	.375	.625	.094	.031	.234	.250	.020	12,000	5.4
1/4-20	P2C-14-S	.500	.812	.105	.046	.296	.312	.025	6,000	10.2
5/16-18	P2C-56-S	.625	1.000	.135	.078	.359	.375	.030	3,000	19.9
3/8-16	P2C-38-S	.625	1.000	.135	.093	.437	.453	.030	3,000	19.9
1/2-13	P2C-12-S	.812	1.250	.187	.125	.593	.609	.033	1,300	41.0

Also Available in Fine Thread Series (NF) in sizes #10 thru 1/2. Dimensions shown are nominal.

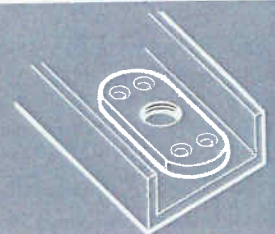
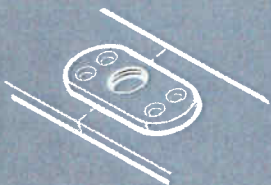

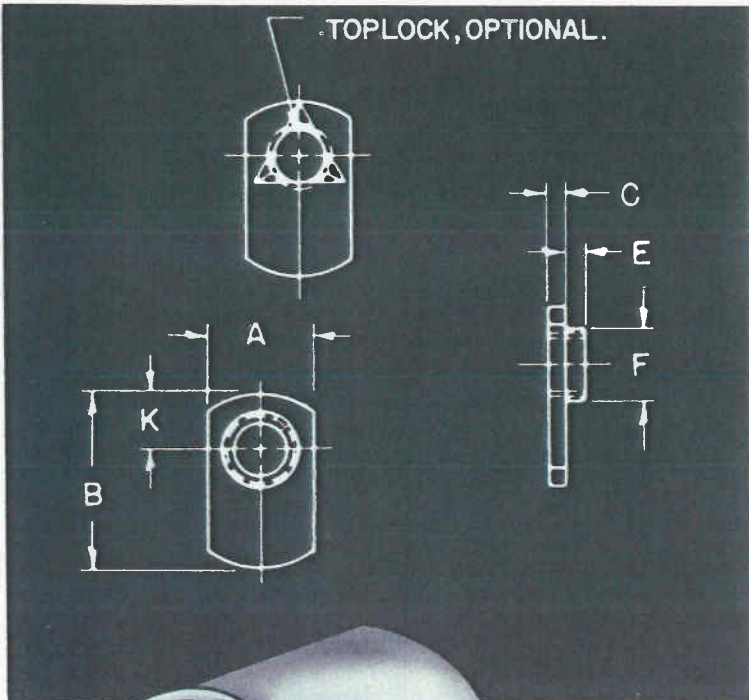

Pilot Spot Weld S1 Series TAB WELD NUTS

The Gripco S1 Series, Tab Weld Nuts are manufactured from low carbon steel. These Tab Weld Nuts have been carefully engineered to offer fast, dependable results on flat sections, confined corners, close spacing, flanges and narrow channels in open and blind applications.

The self-locating pilot positions the nut for assembly. The height of the pilot helps prevent welding spatter from entering the nut threads. The nut can be welded to a wide variety of metal thicknesses.

- Prevailing Torque feature can be incorporated on the side opposite the pilot.
- Can be furnished with plating if required.
- Prices and samples are available upon request.

TAB WELD NUTS PILOT SPOT WELD-S1 SERIES

Size	Part Number	A Width	B Length	C Thickness	K	Pilot		Pilot Hole Diam.	Carton Qty.	Weight Per M
						E	F			
6-32	S1C-6-S	.437	.625	.094	.187	.031	.187	.203	10,000	6.4
8-32	S1C-8-S	.437	.625	.094	.187	.031	.187	.218	10,000	6.3
10-24	S1C-10-S	.437	.625	.094	.187	.031	.234	.250	10,000	6.1
1/4-20	S1C-14-S	.500	.812	.105	.250	.046	.296	.312	6,000	10.2
5/16-18	S1C-56-S	.625	1.125	.135	.343	.078	.359	.375	2,500	21.5
3/8-16	S1C-38-S	.625	1.125	.135	.343	.093	.437	.453	2,500	20.8

Also Available in Fine Thread Series (NF) in sizes #10 thru 3/8. Dimensions shown are nominal.



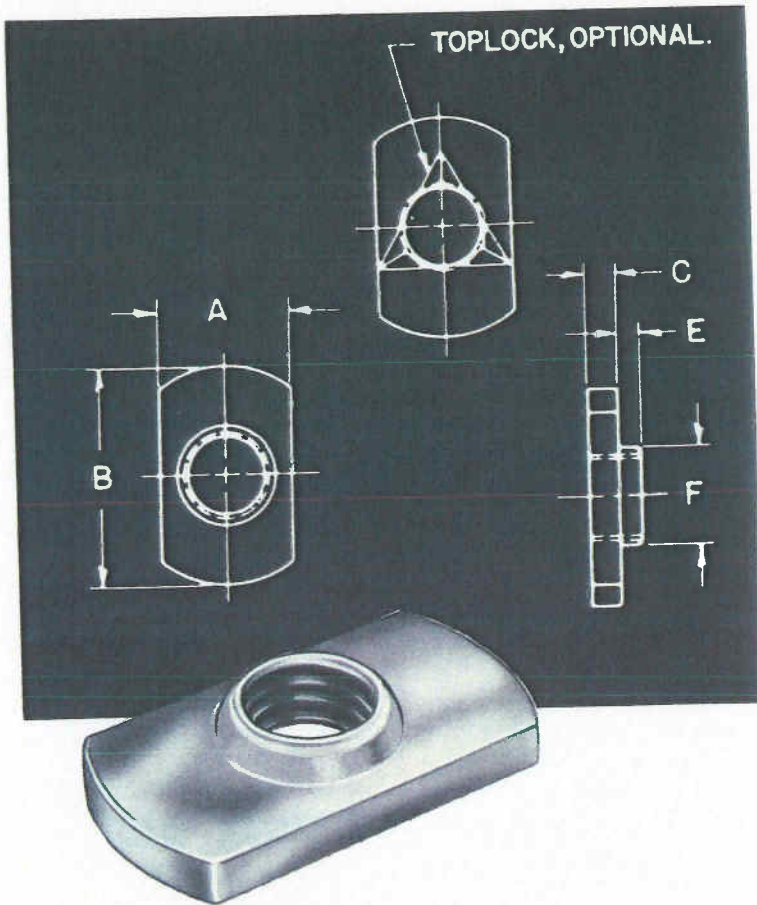

Pilot Spot Weld S2 Series **TAB WELD NUTS**

The Gripco S2 Series, Tab Weld Nuts are manufactured from low carbon steel. These Tab Weld Nuts have been carefully engineered to offer fast, dependable results on flat sections, confined corners, close spacing, flanges and narrow channels in open and blind applications.

The self-locating pilot positions the nut for assembly. The height of the pilot helps prevent welding spatter from entering the nut threads. The nut can be welded to a wide variety of metal thicknesses.

- Prevailing Torque feature can be incorporated on the side opposite the pilot.
- Can be furnished with plating if required.
- Prices and samples are available upon request.

TAB WELD NUTS PILOT SPOT WELD-S2 SERIES

Size	Part Number	A Width	B Length	C Thickness	Pilot		Pilot Hole Diam.	Carton Qty.	Weight Per M
					E	F			
6-32	S2C-6-S	.437	.812	.094	.031	.187	.203	8,000	8.7
8-32	S2C-8-S	.437	.812	.094	.031	.203	.218	8,000	8.6
10-24	S2C-10-S	.437	.812	.094	.031	.234	.250	8,000	8.0
1/4-20	S2C-14-S	.500	1.000	.105	.046	.296	.312	4,500	13.2
5/16-18	S2C-56-S	.625	1.500	.135	.078	.359	.375	2,000	32.1
3/8-16	S2C-38-S	.625	1.500	.135	.093	.438	.453	1,800	32.1
1/2-13	S2C-12-S	.812	1.500	.187	.125	.593	.609	1,000	52.6

Also Available in Fine Thread Series (NF) in sizes #10 thru 1/2. Dimensions shown are nominal.



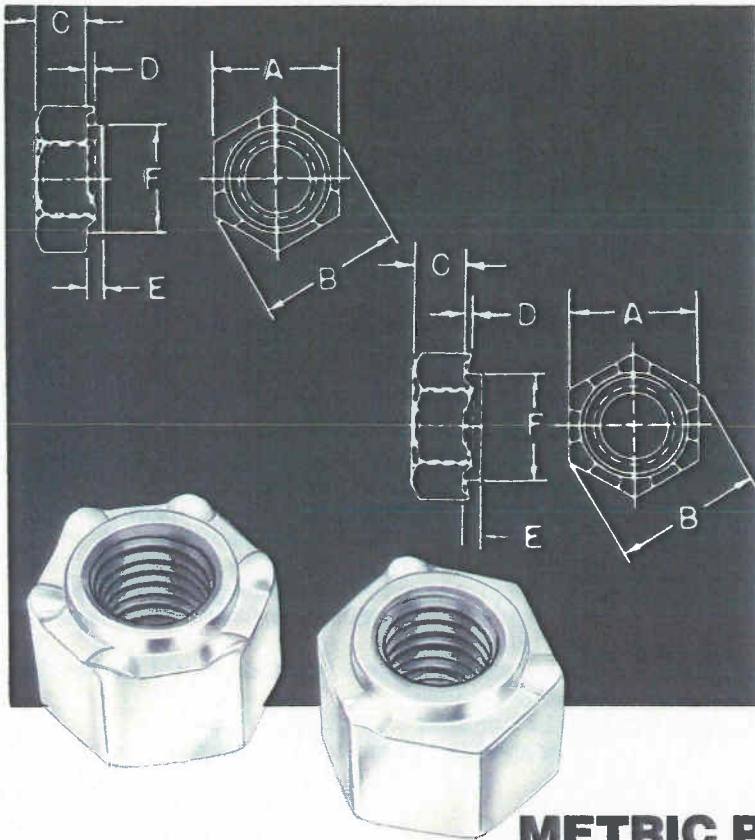

Class 9 – Standard Series METRIC PILOT PROJECTION WELD NUTS

The Gripco Class 9, Standard Series, Metric Pilot Projection Weld Nuts are manufactured from low carbon steel for use with class 9.8 bolts.

These pilot projection weld nuts are engineered for positioning in pierced or drilled holes. The pilot eliminates the need for expensive jigs or centering devices and helps reduce welding spatter from entering the nut threads.

The three and six projection types provide a non-rocking, firm current connection during welding. The mass of the projections is increased in proportion to increased pilot heights to assure weld on thick or thin metals.

- This product is also available with the Gripco prevailing torque feature.
- Prices and samples are available upon request.

METRIC PILOT PROJECTION WELD NUTS CLASS 9 — STANDARD SERIES

	Part No./Size	A Width Across Flats	B Min. Width Across Corners	C Thickness	D Projection Height ± .075	E Pilot Height ± .13	F Pilot Dia. +0.0 -0.3	Pilot Hole Dia.	Carton Qty.	Weight Per M
Short Pilot	P3S9-M4x0.7	10.00	11.05	3.50	.39	.90	6.60	6.90	10,000	4.8
	P3S9-M5x0.8	11.00	12.12	4.60	.39	.90	7.65	8.00	9,000	7.0
	P3S9-M6x1	13.00	14.38	5.35	.44	1.00	9.10	9.50	5,500	11.6
	P3S9-M8x1.25	15.00	16.61	6.85	.44	1.00	11.10	11.50	3,500	17.6
	P3S9-M10x1.50	18.00	20.03	7.95	.55	1.16	13.60	14.00	2,000	31.0
	P3S9-M12x1.75	21.00	23.35	9.65	.65	1.26	16.10	16.50	1,300	45.8
	P3S9-M14x2.0	24.00	26.75	11.25	.65	1.26	19.10	19.50		
	P3S9-M16x2.0	26.00	28.94	13.25	.75	1.36	20.60	21.00		
Long Pilot	P3L9-M4x0.7	10.00	11.05	3.50	.75	1.50	6.60	6.90	10,000	4.8
	P3L9-M5x0.8	11.00	12.12	4.60	.75	1.50	7.65	8.00	9,000	7.0
	P3L9-M6x1	13.00	14.38	5.35	.80	1.60	9.10	9.50	5,500	11.6
	P3L9-M8x1.25	15.00	16.61	6.85	1.00	1.80	11.10	11.50	3,500	17.6
	P3L9-M10x1.50	18.00	20.03	7.95	1.00	1.80	13.60	14.00	2,000	31.0
	P3L9-M12x1.75	21.00	23.35	9.65	1.00	1.80	16.10	16.50	1,300	45.8
	P3L9-M14x2.0	24.00	26.75	11.25	1.00	1.80	19.10	19.50		
	P3L9-M16x2.0	26.00	28.94	13.25	1.00	1.90	20.60	21.00		

Part numbers shown above for 3 projection type.
For 6 projection type, the number to the right of the letter "P" is changed to 6.

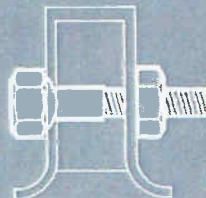
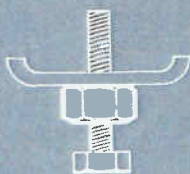

Class 9 – Counterbore Series **METRIC PILOT PROJECTION WELD NUTS**

The Gripco Class 9, Counterbore Series, Metric Pilot Projection Weld Nuts are manufactured from low carbon steel for use with class 9.8 bolts.

These pilot projection weld nuts are engineered for positioning in pierced or drilled holes. The pilot eliminates the need for expensive jigs or centering devices and helps reduce welding spatter from entering the nut threads.

The three and six projection types provide a non-rocking, firm current connection during welding. The mass of the projections is increased in proportion to increased pilot heights to assure weld on thick or thin metals.

- This product is also available with the Gripco prevailing torque feature.
- Prices and samples are available upon request.

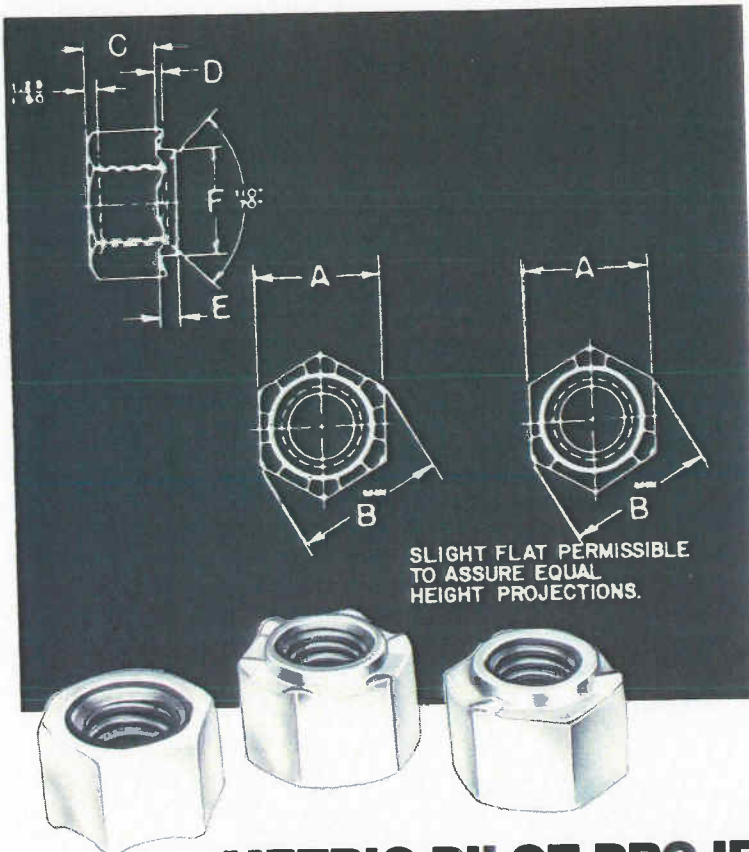

METRIC PILOT PROJECTION WELD NUTS CLASS 9 — COUNTERBORE SERIES

	Part No./Size	A Width Across Flats	B Min. Width Across Corners	C Thickness	D Projection Height ± .075	E Pilot Height ± .13	F Pilot Dia. + 0.0 - 0.3	Pilot Hole Dia.	Carton Qty.	Weight Per M
Short Pilot	E6S9-M4x0.7	10.00	11.10	6.25	.45	.70	6.60	6.90		
	E6S9-M5x0.8	11.00	12.40	6.55	.45	.70	7.60	8.00	7,000	9.0
	E6S9-M6x1	13.00	14.10	7.75	.45	.70	9.00	9.40	4,000	15.7
	E6S9-M8x1.25	15.00	16.80	9.05	.45	.70	11.10	11.50	2,500	23.7
	E6S9-M10x1.5	18.00	19.30	12.05	.55	1.00	13.40	13.80	1,500	42.7
	E6S9-M12x1.75	21.00	22.80	14.05	.65	1.20	16.10	16.50	900	66.1
	E6S9-M14x2.0	24.00	26.40	16.20	.65	1.20	19.00	19.50		
E6S9-M16x2.0	26.00	28.10	18.70	.65	1.20	20.50	21.00	400	180.9	
Long Pilot	E6L9-M6x1	13.00	14.10	7.75	1.00	1.80	9.00	9.40	4,000	15.7
	E6L9-M8x1.25	15.00	16.80	9.05	1.00	1.80	11.10	11.50	2,500	23.7
	E6L9-M10x1.5	18.00	19.30	12.05	1.00	1.80	13.40	13.80	1,500	42.7
	E6L9-M12x1.75	21.00	22.80	14.05	1.00	1.80	16.10	16.50	900	66.1
	E6L9-M14x2	24.00	26.40	16.20	1.00	1.80	19.00	19.50		
	E6L9-M16x2	26.00	28.10	18.70	1.00	1.80	20.50	21.00	400	180.9

Part numbers shown above for 6 projection type.
For 3 projection type, the number to the right of the letter "E" is changed to 3.

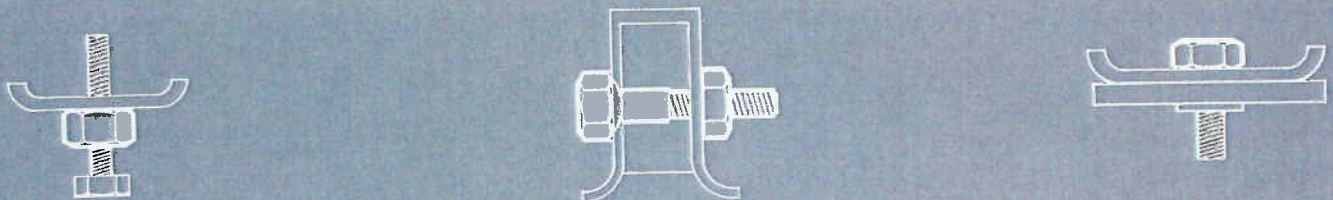

Class 9 Series METRIC CLINCH NUTS

The Gripco Class 9 Series, Metric Clinch Nuts are manufactured from low carbon steel. These clinch nuts are designed for use with sheetmetal or similar materials where extruding and tapping are not advisable or possible. They may be used in open or blind applications.

These clinch nuts are designed with a hex pilot to prevent rotation in a hex hole. This product can be staked for floating applications to accommodate bolt misalignment. They also can be clinched solid providing excellent push out strength for rigid applications.

Where flush mounting is required, a button die in combination with a hex punch provides an embossed relief in the stamping. These nuts can be automatically fed and clinched on volume production lines or individually clinched with riveters, orbital riveters, or arbor type presses.

- This product is also available with the Gripco prevailing torque feature.
- Prices and samples are available upon request.

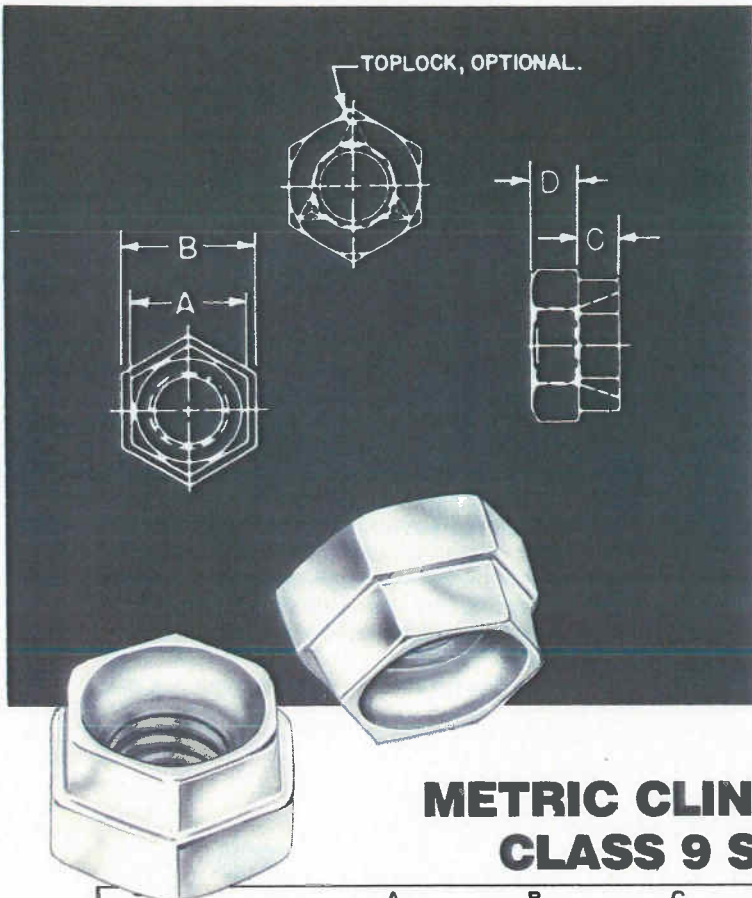

METRIC CLINCH NUTS CLASS 9 SERIES

Part No./Size	A Pilot Width	B Nut Width	C Pilot Height	D Nut Height	Hex Hole In Plate	Carton Qty.	Weight Per M
K9-M6x1	10.90	13.23	3.18	5.44	11.10	4,000	15.8
K9-M8x1.25	12.47	14.83	3.96	6.86	12.70		
K9-M10x1.50	14.00	17.02	4.75	8.36	14.27		
K9-M12x1.75	18.85	22.00	6.35	9.86	15.88		
K9-M14x2	22.00	25.02	7.14	11.61	19.05		
K9-M16x2	23.42	26.59	7.92	13.61	23.80		

Clinching Force Requirements

Size Nut	Approx. Metal Thickness	Approx. Clinching Force For Steel
M6x1	1.40	10,000 lbs.
M8x1.25	1.40	12,000 lbs.
M10x1.50	1.40	14,000 lbs.
M12x1.75	1.90	20,000 lbs.
M14x2	2.54	24,000 lbs.
M16x2	3.35	36,000 lbs.

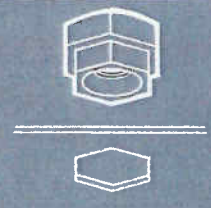
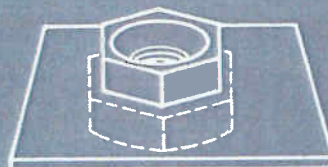
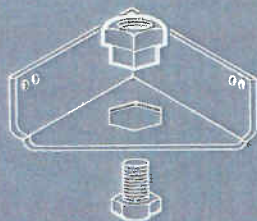

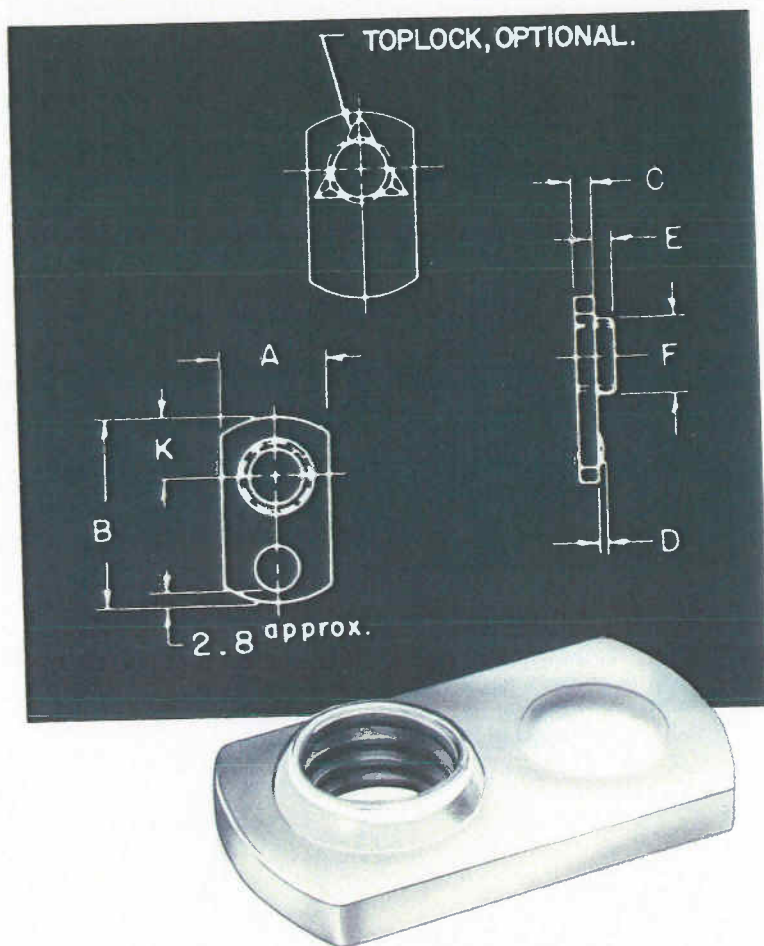

Pilot Projection P1M Series **METRIC TAB WELD NUTS**

The Gripco Pilot Projection P1M Series Metric Tab Weld Nuts are manufactured from low carbon steel. These tab weld nuts have been carefully engineered to offer fast, dependable results on flat sections, confined corners, close spacing, flanges and narrow channels in open and blind applications.

The self-locating pilot positions the nut for assembly. The height of the pilot helps prevent welding spatter from entering the nut threads. The nut can be welded to a wide variety of metal thicknesses.

- Prevailing Torque feature can be incorporated on the side opposite the pilot.
- Prices and samples are available upon request.

METRIC TAB WELD NUTS PILOT PROJECTION-P1M SERIES

Part Number/Size	A Width		B Length	C Thick-ness	K Center Line	E Pilot Height	F Dia.	Pilot Hole Dia.	D Proj. Ht.
	Max.	Min.							
P1-M4x0.7	11.4	10.9	15.9	2.4	4.7	0.8	5.2	5.6	0.5
P1-M5x0.8	11.4	10.9	15.9	2.4	4.7	0.8	5.9	6.4	0.5
P1-M6x1.0	13.1	12.4	20.6	2.7	6.4	1.2	7.5	8.0	0.64
P1-M8x1.25	16.3	15.6	28.6	3.4	8.7	2.0	9.1	9.6	0.76
P1-M10x1.50	16.3	15.6	28.6	3.4	8.7	2.4	11.1	11.5	0.76

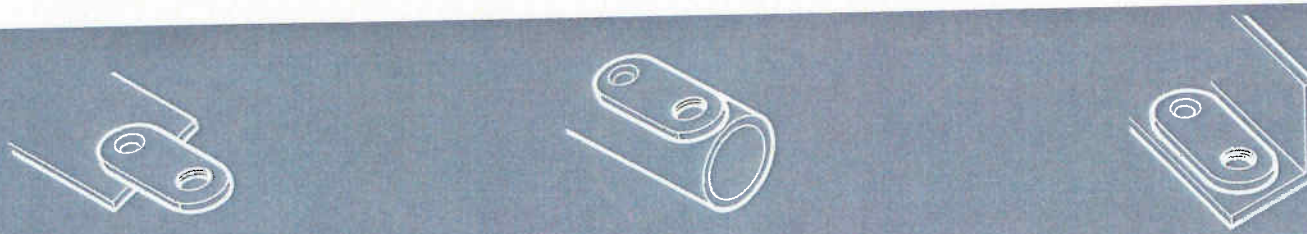

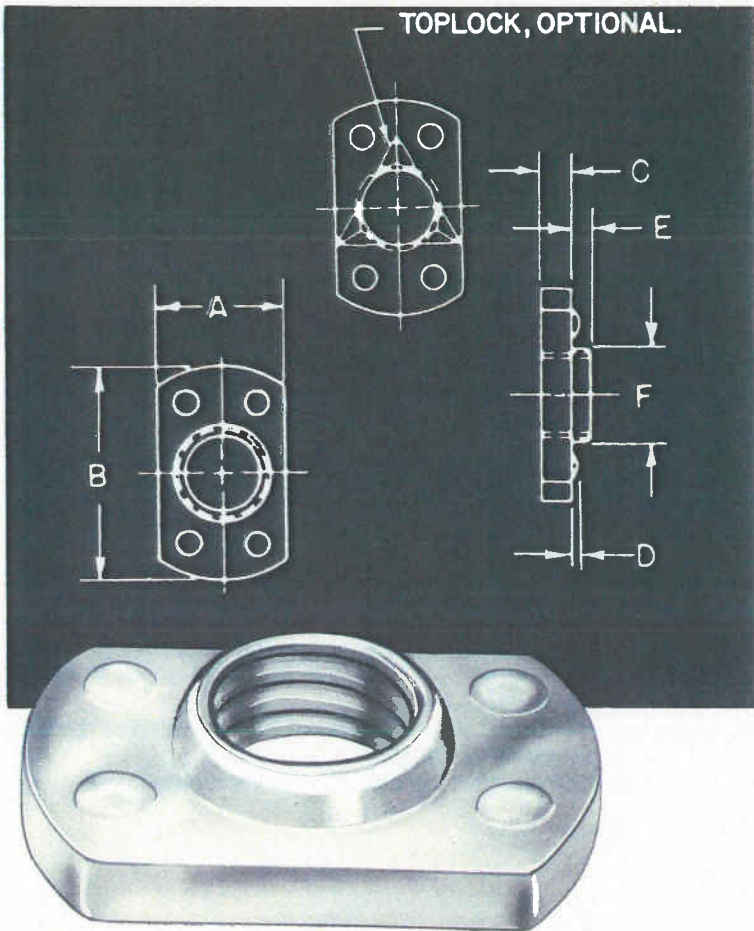

Pilot Projection P2M Series **METRIC TAB WELD NUTS**

The Gripco Pilot Projection P2M Series, Metric Tab Weld Nuts are manufactured from low carbon steel.

These tab nuts have been carefully engineered to offer fast, dependable results on flat sections, confined corners, close spacing, flanges and narrow channels in open and blind applications.

The self-locating pilot positions the nut for assembly. The height of the pilot helps prevent welding spatter from entering the nut threads. The nut can be welded to a wide variety of metal thicknesses.

- Prevailing Torque feature can be incorporated on the side opposite the pilot.
- Prices and samples are available upon request.

METRIC TAB WELD NUTS PILOT PROJECTION-P2M SERIES

Part Number/Size	A Width		B Length	C Thick-ness	E Pilot Height	F Dia.	Pilot Hole Dia.	D Proj. Ht.
	Max.	Min.						
P2-M4x0.7	9.8	9.3	15.9	2.4	0.8	5.2	5.6	0.5
P2-M5x0.8	9.8	9.3	15.9	2.4	0.8	5.9	6.4	0.5
P2-M6x1.0	13.1	12.4	20.6	2.7	1.2	7.5	8.0	0.64
P2-M8x1.25	16.3	15.6	25.4	3.4	2.0	9.1	9.6	0.76
P2-M10x1.50	16.3	15.6	25.4	3.4	2.4	11.1	11.5	0.76

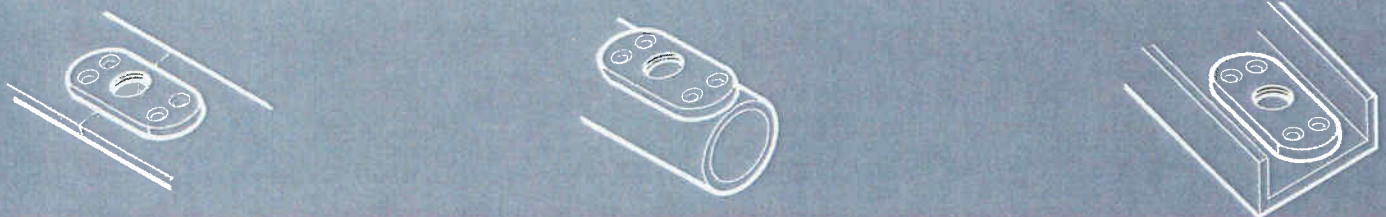

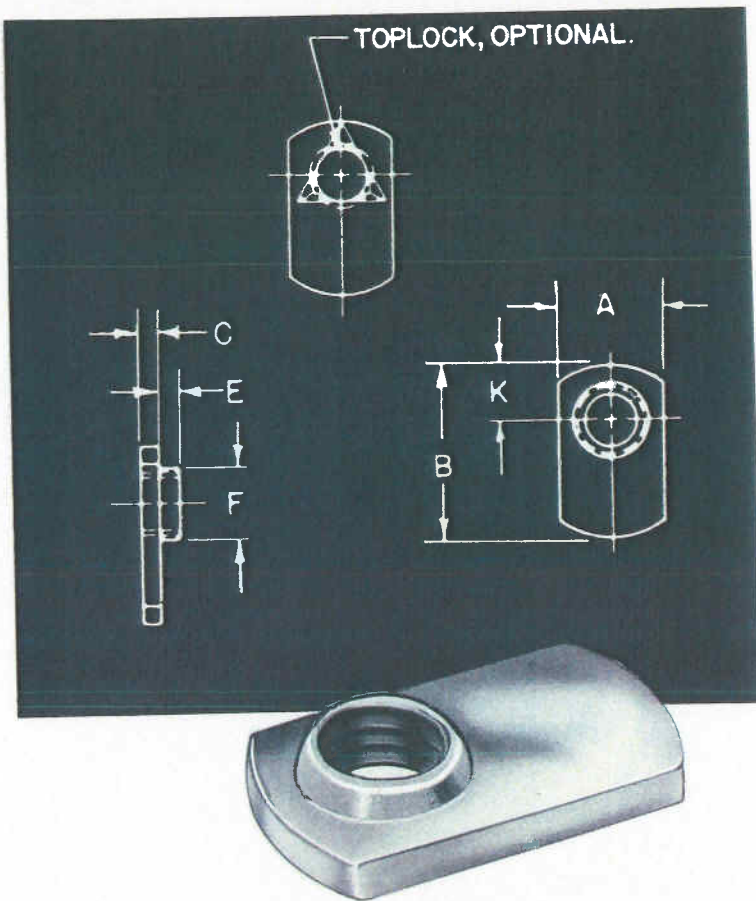

Pilot Projection S1M Series **METRIC TAB WELD NUTS**

The Gripco Pilot Projection S1M Series, Metric Tab Weld Nuts are manufactured from low carbon steel.

These tab weld nuts have been carefully engineered to offer fast, dependable results on flat sections, confined corners, close spacing, flanges and narrow channels in open and blind applications.

The self-locating pilot positions the nut for assembly. The height of the pilot helps prevent welding spatter from entering the nut threads. The nut can be welded to a wide variety of metal thicknesses.

- Prevailing Torque feature can be incorporated on the side opposite the pilot.
- Prices and samples are available upon request.

METRIC TAB WELD NUTS PILOT SPOT WELD-S1M SERIES

Part Number/Size	A Width		B Length	C Thick-ness	K Center Line Loc.	E Pilot Height	F Pilot Dia.	Pilot Hole Dia.
	Max.	Min.						
S1-M4x0.7	11.4	10.9	15.9	2.4	4.7	0.8	5.2	5.6
S1-M5x0.8	11.4	10.9	15.9	2.4	4.7	0.8	5.9	6.4
S1-M6x1.0	13.1	12.4	20.6	2.7	6.4	1.2	7.5	8.0
S1-M8x1.25	16.3	15.6	28.6	3.4	8.7	2.0	9.1	9.6
S1-M10x1.50	16.3	15.6	28.6	3.4	8.7	2.4	11.1	11.5



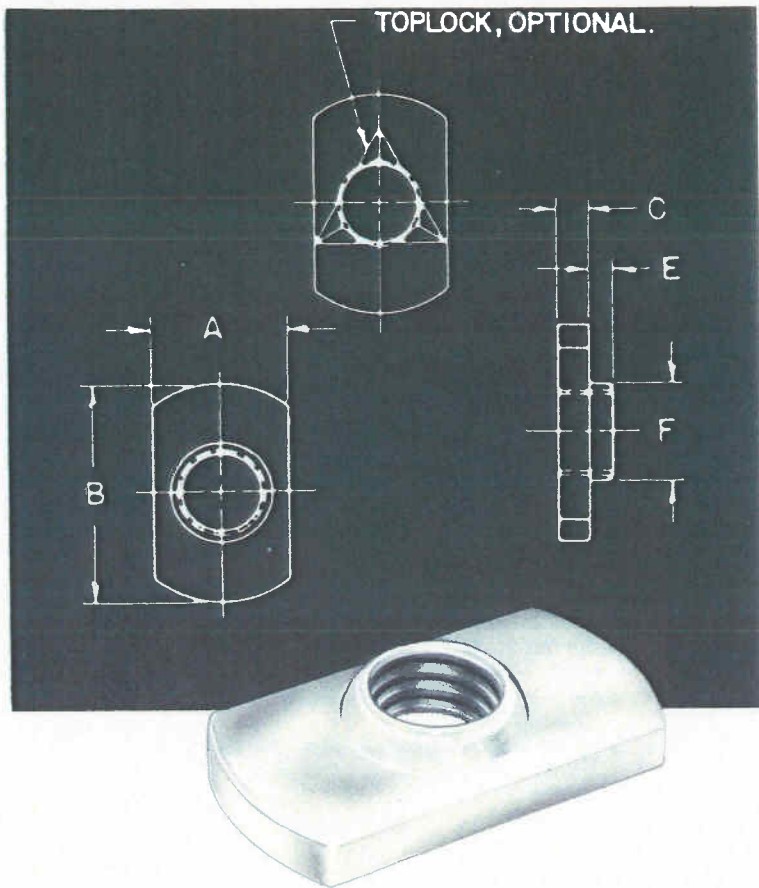

Pilot Projection S2M Series METRIC TAB WELD NUTS

The Gripco Pilot Projection S2M Series, Metric Tab Weld Nuts are manufactured from low carbon steel.

These tab weld nuts have been carefully engineered to offer fast, dependable results on flat sections, confined corners, close spacing, flanges and narrow channels in open and blind applications.

The self-locating pilot positions the nut for assembly. The height of the pilot helps prevent welding spatter from entering the nut threads. The nut can be welded to a wide variety of metal thicknesses.

- Prevailing Torque feature can be incorporated on the side opposite the pilot.
- Prices and samples are available upon request.

METRIC TAB WELD NUTS PILOT SPOT WELD-S2M SERIES

Part Number/Size	A Width		B Length	C Thick-ness	Pilot		Pilot Hole Dia.
	Max.	Min.			E Height	F Dia.	
S2-M4x0.7	11.4	10.9	20.6	2.4	0.8	5.2	5.6
S2-M5x0.8	11.4	10.9	20.6	2.4	0.8	5.9	6.4
S2-M6x1	13.1	12.4	25.4	2.7	1.2	7.5	8.0
S2-M8x1.25	16.3	15.6	38.1	3.4	2.0	9.1	9.6
S2-M10x1.5	16.3	15.6	38.1	3.4	2.4	11.1	11.5



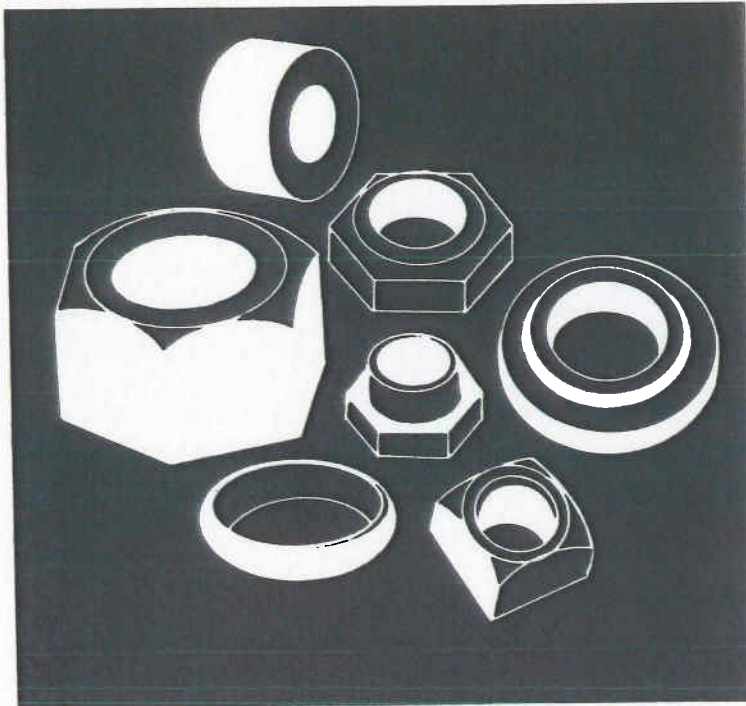

Finished Forging Series **HOT FORMED PRODUCTS**

The Gripco Finished Forging Series, Hot Formed Products are formed by converting roller bar stock into a wide variety of accurate parts, from very simple to complex shapes.

Teamed with automatic bar heaters, these hot formers combine feeding, heating, and forging operations into a fully automated production system starting with bundles of mill length bars at one end and ejecting pierced, precision forgings at the other end.

In operation, heated bars are continually fed to the hot former, cut to length and shaped in three consecutive forging operations. As a rule, the first station is used for preforming, the second for finish-forming and the third for piercing. A finished forging is ejected at each stroke.

Gripco manufactures large, special diameter hexagon nuts and hexagon flange nuts, on hot forming equipment.

- Prices and samples are available upon request.

Preformed Forging Series **HOT FORMED PRODUCTS**

Gripco automatic hot forming is four times faster than conventional forging. Preformed material costs are reduced from those of conventional drop forging, because the automatic hot forging is closer to finish part size (where subsequent machining is required). Since the starting material is in round bar form, the easiest parts to form are those closest to the starting shape: disc, rings, and cylinders. The outer surface of the forgings need not be round, they can be square or hexagon.

HOT FORMED PRODUCTS PREFORMED FORGING SERIES

	20 Series	30 Series
Initial weight of forgings	.045-.33 lb.	.11-1.55 lb.
Max. outer diameter	1.40 in.	2.52 in.
Max. outer diameter for combination rings	1.18 in.	2.18 in.
Max. width across flats for hex nuts	1.25 in.	2.20 in.
Bar diameter	.55-1.00 in.	.75-1.60 in.
Cutoff length	.60-1.60 in.	.90-2.85 in.
Forging stations	3	3
Output per minute (continuously variable)	90-150	70-120
Forging load	60 kN	2300 kN

WARRANTY POLICY

In cases where Gripco products are either heat treated, welded or given a protective coating following delivery to the purchaser, the Gripco Fastener Division shall not be held responsible for failures of the product to meet dimensional, mechanical or performance requirements.

RETURNED GOODS POLICY

The return of goods by customers will not be allowed without prior written authorization. Please contact the South Whitley sales office with any request for the return of material.

QUALITY ASSURANCE POLICY

Unless otherwise specified by the customer at the time of the inquiry (verbal or written) or on the purchase order, parts will be processed in accordance with standard in-house procedures. Certifications require prior notification. Please contact Gripco, South Whitley sales office for additional information on your requirements.

COUNTRY OF ORIGIN

All finished products illustrated in this catalog are manufactured in the United States of America. Manufacturing facilities are located at South Whitley, Indiana and Montpelier, Indiana.

GRIPCO®

**Emhart Fastening Technologies
Industrial Division**

**510 River Road
Shelton, CT 06484
Tel. (203) 944-1711
Fax (800) 220-4286**

Canadian Office

**3545 Thimens Boulevard
St. Laurent, Quebec, H4R 1V5
Tel. (514) 333-8080
Fax (514) 338-3829**

**Emhart
GRIPCO**

A  **BLACKS DECKER** COMPANY